

OPERATION & MAINTENANCE

PREMIUM **V**

60HZ

GEO**SMART** ENERGY

IGW7-0018S



 **WARNING**



WARNING: Before performing service or maintenance operations on the system, turn off main power switches to the unit. Electrical shock could cause serious personal injury.

WARNING: All products are designed, tested, and manufactured to comply with the latest publicly released and available edition of UL 60335-2-40 for electrical safety certification. All field electrical connections must follow the National Electrical Code (NEC) guide standards and / or any local codes that may be applicable for the installation.

WARNING: Only factory authorized personnel are approved for startup, check test and commissioning of this unit.

INSTALLER: Please take the time to read and understand these instructions prior to any installation. Installer must give a copy of this manual to the owner.

Definition of Warnings and Symbols

 DANGER	Indicates a situation that results in death or serious injury.
 WARNING	Indicates a situation that could result in death or serious injury.
 CAUTION	Indicates a situation that could result in minor or moderate injury.
NOTICE	Indicates a situation that could result in equipment or property damage.

For the User

 **WARNING**

This appliance is not intended for use by persons (including children) with reduced physical, sensory, or mental capabilities, or lack of experience and knowledge, unless they have been given supervision or instruction concerning use of the appliance by a person responsible for their safety.

Children should be supervised to ensure that they do not play with the appliance.

Keep this manual in a safe place in order to provide your serviceman with necessary information.

NOTICE

NOTICE: To avoid equipment damage, do not leave the system filled in a building without heat during cold weather, unless adequate freeze protection levels of antifreeze are used. Heat exchangers do not fully drain and will freeze unless protected, causing permanent damage.

Table of Contents

UNIT OVERVIEW

Nomenclatures	6
AHRI Data	7
Physical Data	9
Dimensional Data	10

OPERATING PRINCIPLES

Electrical Data	14
Auxiliary Heat Ratings	14
Auxiliary Heat Electrical Data	14
Blower Performance Data	15
Reference Calculations	16
Legend and Notes	16
Operating Limits	16
Antifreeze Corrections	17
Correction Factor Tables	18
Heat of Extraction/Heat of Rejection	19
Water Quality	20
Operating Parameters	21
Pressure Drop	22
Operation Logic Data Table	23
Aurora Controls Operation	24
Refrigerant Circuit Guideline	35
Electrical Information	36
Electronic Thermostat Installation	37
Electrical Information Flow Centers	38
Closed Loop/Open Loop Ground Source Systems	42

SERVICE AND TROUBLESHOOTING

Compressor and Thermistor Resistance	45
Unit Startup	46
Operating Limits	48
Preventative Maintenance	48
Replacement Procedures	49
Troubleshooting	49
Aurora Interface Diagnostic (AID) Tool	50
Preliminary Checkout Procedure	50
Troubleshooting Checklist	51
Control Board Troubleshooting Steps	52
Control Board Troubleshooting Flow Charts	54
Communicating Thermostat Troubleshooting Guide	66
Control Board Signals	68
Jumping the Control Board	71
Troubleshooting Forms	74
Performance Data	77
Service Parts Table	85
Decommissioning	87
Refrigerant Recovery	88
Refrigerant Removal and Evacuation	88
Charging Procedures	89

REVISION GUIDE	91
-----------------------------	-----------

General Installation Information

NOTICE: Do not store or install units in corrosive environments or in locations subject to temperature or humidity extremes. Corrosive conditions and high temperature or humidity can significantly reduce performance, reliability, and service life.

NOTICE: A minimum of 24 in. clearance should be allowed for access to front access panel.

NOTICE: To avoid equipment damage, DO NOT use these units as a source of heating or cooling during the construction process. The mechanical components and filters can quickly become clogged with construction dirt and debris, which may cause system damage and void product warranty.

For the Installer

If you are NOT sure how to install or operate the unit, contact your dealer.

Installing and servicing air conditioning and heating equipment can be hazardous due to system pressure and electrical components. Only trained and qualified service personnel should install, repair or service heating and air conditioning equipment. When working on heating and air conditioning equipment, observe precautions in the literature, tags and labels attached to the unit and other safety precautions that may apply.

This manual contains specific information about the required qualification of the working personnel for maintenance, service and repair operations. Every working procedure that affects safety means shall only be carried out by competent persons.

Examples for such working procedures are:

- breaking into the refrigerating circuit;
- opening of sealed components or ventilated enclosures.

Follow all safety codes. Wear safety glasses and work gloves. Use quenching cloth for brazing operations. Have fire extinguisher available for all brazing operations. Follow all procedures to remain in compliance with national gas regulations.

Prior to beginning work on systems containing FLAMMABLE REFRIGERANTS, safety checks are necessary to ensure that the risk of ignition is minimized. Work shall be undertaken under a controlled procedure so as to minimise the risk of a flammable gas or vapor being present while the work is being performed. All maintenance staff and others working in the local area shall be instructed on the nature of work being carried out. Work in confined spaces shall be avoided.

The area shall be checked with an appropriate refrigerant detector prior to and during work, to ensure the technician is aware of potentially toxic or flammable atmospheres. Ensure that the leak detection equipment being used is suitable for use with all applicable refrigerants, i.e. non-sparking, adequately sealed or intrinsically safe.

If any hot work is to be conducted on the refrigerating equipment or any associated parts, appropriate fire extinguishing equipment shall be available to hand. Have a dry powder or CO2 fire extinguisher adjacent to the charging area.

No person carrying out work in relation to a REFRIGERATING SYSTEM which involves exposing any pipe work shall use any sources of ignition in such a manner that it may lead to the risk of fire or explosion. All possible ignition sources, including cigarette smoking, should be kept sufficiently far away from the site of installation, repairing, removing and disposal, during which refrigerant can possibly be released to the surrounding space. Prior to work taking place, the area around the equipment is to be surveyed to make sure that there are no flammable hazards or ignition risks. "No Smoking" signs shall be displayed.

Where electrical components are being changed, they shall be fit for the purpose and to the correct specification. At all times the manufacturer's maintenance and service guidelines shall be followed. If in doubt, consult the manufacturer's technical department for assistance.

The following checks shall be applied to installations using FLAMMABLE REFRIGERANTS:

- the actual REFRIGERANT CHARGE is in accordance with the room size within which the refrigerant containing parts are installed;
- the ventilation machinery and outlets are operating adequately and are not obstructed;
- if an indirect refrigerating circuit is being used, the secondary circuit shall be checked for the presence of refrigerant;
- marking to the equipment continues to be visible and legible. Markings and signs that are illegible shall be corrected;
- refrigerating pipe or components are installed in a position where they are unlikely to be exposed to any substance which may corrode refrigerant containing components, unless the components are constructed of materials which are inherently resistant to being corroded or are suitably protected against being so corroded.

Instructions for Equipment Using R-454B Refrigerant

WARNING

- **Do NOT pierce or burn**
- **Do NOT use means to accelerate the defrosting process or to clean the equipment, other than those recommended by the manufacturer**
- **Be aware that refrigerants may not contain an odor**

WARNING

- **The Appliance should be stored so as to prevent mechanical damage and in a room without continuously operating ignition sources (example: open flames, an operating gas appliance or an operating electric heater)**

General Installation Information

WARNING

Ventilated Area: ensure that the area is in the open or that it is adequately ventilated before breaking into the system of conducting any hot work. A degree of ventilation should continue during the period that the work is carried out. The ventilation should safely disperse any released refrigerant and preferably expel it. Keep ventilation area clear of obstructions!

WARNING

Do NOT use potential sources of ignition in searching for or detection of refrigerant leaks. A halide torch (or any other detector using a naked flame) shall not be used.

The following leak detection methods are deemed acceptable for all refrigerant systems. Electronic leak detectors may be used to detect refrigerant leaks but, in the case of FLAMMABLE REFRIGERANTS, the sensitivity may not be adequate, or may need re-calibration. (Detection equipment shall be calibrated in a refrigerant-free area.) Ensure that the detector is not a potential source of ignition and is suitable for the refrigerant used. Leak detection equipment shall be set at a percentage of the LFL of the refrigerant and shall be calibrated to the refrigerant employed, and the appropriate percentage of gas (25 % maximum) is confirmed. Leak detection fluids are also suitable for use with most refrigerants but the use of detergents containing chlorine shall be avoided as the chlorine may react with the refrigerant and corrode the copper pipe-work. NOTE Examples of leak detection fluids are bubble method, fluorescent method agents. If a leak is suspected, all naked flames shall be removed/extinguished. If a leakage of refrigerant is found which requires brazing, all of the refrigerant shall be recovered from the system, or isolated (by means of shut off valves) in a part of the system remote from the leak. Removal of refrigerant shall follow the procedure outlined in this manual.

Installation Site

This equipment has been evaluated to be installed up to a maximum altitude of 3000m (9843ft) and should not be installed at an altitude greater than 3000m. For installation only in locations not accessible to the general public.

WARNING

For appliances using A2L refrigerants connected via an air duct system to one or more rooms, only auxiliary devices approved by the appliance manufacturer or declared suitable with the refrigerant shall be installed in connecting ductwork. The manufacturer shall list in the instructions all approved auxiliary devices by manufacturer and model number for use with the specific appliance, if those devices have a potential to become an ignition source.

Installation Space Requirements

NOTE: Equipment with refrigerant charge less than 64 oz does not require have a minimum floor area requirement and does not require a refrigerant leak detection sensor. The sensor might be added as a feature.

WARNING

Equipment containing R-454B refrigerant shall be installed, operated, and stored in a room with floor area larger than the area defined in the "Minimum Floor Area" chart based on the total refrigerant charge in the system. This requirement applies to indoor equipment with or without a factory refrigerant leakage sensor.

CAUTION

It is not recommended to use a potable water source for this equipment water supply.

WARNING

This equipment comes with a factory installed Refrigerant Detection Device which is capable of determining it's specified end-of-life and replacement instructions. Refrigerant sensors for refrigerant detection systems shall only be replaced with sensors specified by the appliance manufacture.

WARNING

Take sufficient precautions in case of refrigerant leakage. If refrigerant gas leaks, ventilate the area immediately.
POSSIBLE RISKS: Excessive refrigerant concentrations in a closed room can lead to oxygen deficiency

WARNING

ALWAYS recover the refrigerant. Do NOT release them directly into the environment. Follow handling instructions carefully in compliance with national regulations.

WARNING

Check that cabling will not be subject to wear, corrosion, excessive pressure, vibration, sharp edges or any other adverse environmental effects. The check shall also take into account the effects of aging or continual vibration from sources such as compressors or fans.

Nomenclature

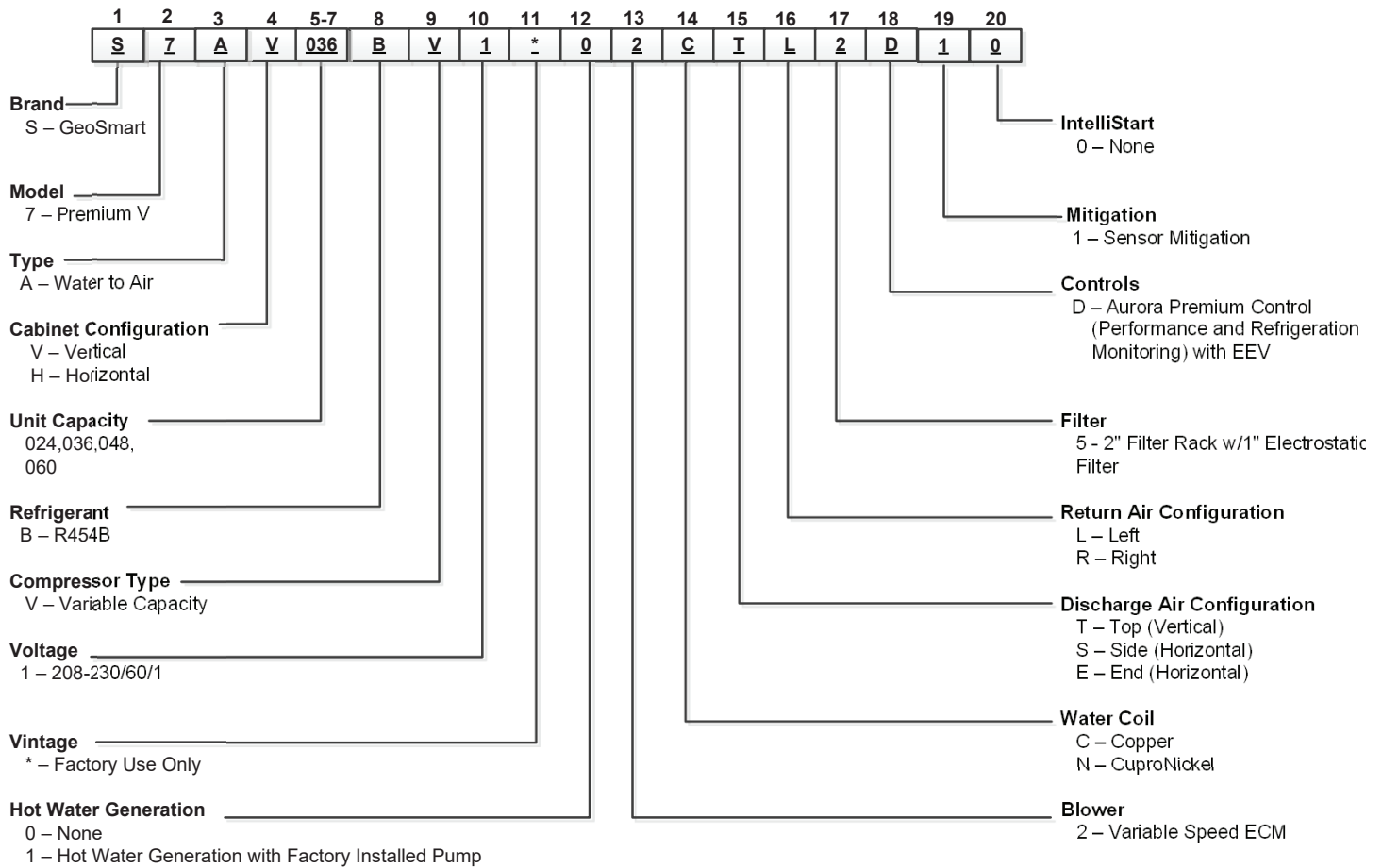

Rev.: 7/31/24

AHRI Data

The performance standard AHRI/ASHRAE/ISO 13256-1 became effective January 1, 2000 and replaces ARI Standards 320, 325, and 330. This new standard has three major categories: Water Loop (comparable to ARI 320), Ground Water (ARI 325), and Ground Loop (ARI 330). Although these standards are similar there are some differences:

Unit of Measure: The Cooling COP

The cooling efficiency is measured in EER (US version measured in Btu/h per Watt. The Metric version is measured in a cooling COP (Watt per Watt) similar to the traditional COP measurement.

Water Conditions Differences

Entering water temperatures have changed to reflect the centigrade temperature scale. For instance the water loop heating test is performed with 68°F (20°C) water rounded down from the old 70°F (21.1°C).

Air Conditions Differences

Entering air temperatures have also changed (rounded down) to reflect the centigrade temperature scale. For instance the cooling tests are performed with 80.6°F (27°C) dry bulb and 66.2°F (19°C) wet bulb entering air instead of the traditional 80°F (26.7°C) DB and 67°F (19.4°C) WB entering air temperatures. 80.6/66.2 data may be converted to 80/67 using the entering air correction table. This represents a significantly lower relative humidity than the old 80/67 of 50% and will result in lower latent capacities.

Pump Power Correction Calculation

Within each model, only one water flow rate is specified for all three groups and pumping Watts are calculated using the following formula. This additional power is added onto the existing power consumption.

- Pump power correction = $(\text{gpm} \times 0.0631) \times (\text{Press Drop} \times 2990) / 300$
Where 'gpm' is waterflow in gpm and 'Press Drop' is the pressure drop through the unit heat exchanger at rated water flow in feet of head.

Blower Power Correction Calculation

Blower power is corrected to zero external static pressure using the following equation. The nominal airflow is rated at a specific external static pressure. This effectively reduces the power consumption of the unit and increases cooling capacity but decreases heating capacity. These Watts are significant enough in most cases to increase EER and COPs fairly dramatically over ARI 320, 325, and 330 ratings.

- Blower Power Correction = $(\text{cfm} \times 0.472) \times (\text{esp} \times 249) / 300$
Where 'cfm' is airflow in cfm and 'esp' is the external static pressure at rated airflow in inches of water gauge.

ISO Capacity and Efficiency Calculations

The following equations illustrate cooling calculations:

- ISO Cooling Capacity = Cooling Capacity (Btu/h) + (Blower Power Correction (Watts) x 3.412)
- ISO EER Efficiency (W/W) = ISO Cooling Capacity (Btu/h) x 3.412 / [Power Input (Watts) - Blower Power Correction (Watts) + Pump Power Correction (Watt)]

The following equations illustrate heating calculations:

- ISO Heating Capacity = Heating Capacity (Btu/h) - (Blower Power Correction (Watts) x 3.412)
- ISO COP Efficiency (W/W) = ISO Heating Capacity (Btu/h) x 3.412 / [Power Input (Watts) - Blower Power Correction (Watts) + Pump Power Correction (Watt)]

Comparison of Test Conditions

	ARI 320	ISO/AHRI 13256-1 WLHP	ARI 325	ISO/AHRI 13256-1 GWHP	ARI 330	ISO/AHRI 13256-1 GLHP
Cooling						
Entering Air - DB/WB °F	80/67	80.6/66.2	80/67	80.6/66.2	80/67	80.6/66.2
Entering Water - °F	85	86	50/70	59	77	77
Fluid Flow Rate	*	**	**	**	**	**
Heating						
Entering Air - DB/WB °F	70	68	70	68	70	68
Entering Water - °F	70	68	50/70	50	32	32
Fluid Flow Rate	*	**	**	**	**	**

NOTES: * Flow rate is set by 10°F rise in standard cooling test

** Flow rate is specified by the manufacturer

Part load entering water conditions not shown

WLHP = Water Loop Heat Pump; GWHP = Ground Water Heat Pump; GLHP = Ground Loop Heat Pump

Conversions:

Airflow (lps) = $\text{cfm} \times 0.472$;

WaterFlow (lps) = $\text{gpm} \times 0.0631$;

ESP (Pascals) = $\text{ESP (in wg)} \times 249$;

Press Drop (Pascals) = $\text{Press Drop (ft hd)} \times 2990$

AHRI Data

Variable Speed Residential AHRI Data

ECM Motor
 AHRI/ASHRAE/ISO 13256-1
 English (IP) Units

Model	Capacity Modulation	Flow Rate Clg/Htg	Water Loop Heat Pump				Ground Water Heat Pump				Ground Loop Heat Pump			
			Cooling EWT 86°F		Heating EWT 68°F		Cooling EWT 59°F		Heating EWT 50°F		Cooling Full Load 77°F Part Load 68°F		Heating Full Load 32°F Part Load 41°F	
		cfm	Capacity Btuh	EER Btuh/W	Capacity Btuh	COP	Capacity Btuh	EER Btuh/W	Capacity Btuh	COP	Capacity Btuh	EER Btuh/W	Capacity Btuh	COP
024	Full	850/1150	22,200	16.9	39,200	6.0	26,300	37.8	32,100	5.0	24,100	23.6	24,800	4.1
	Part		9,300	21.5	13,500	8.4	11,900	57.4	10,100	6.0	13,400	41.0	12,400	5.1
036	Full	1300/1500	33,500	15.3	51,800	5.4	38,200	28.7	41,900	4.7	35,800	18.1	32,900	3.8
	Part		11,900	20.4	17,000	7.9	11,400	51.6	14,000	5.9	13,400	41.0	12,400	5.1
048	Full	1500/1800	41,500	16.0	66,000	4.8	49,000	27.4	54,500	4.2	45,000	18.9	42,000	3.6
	Part		20,000	24.0	23,200	7.8	19,000	56.0	19,000	6.1	15,600	47.0	16,900	5.1
060	Full	1800/2200	50,000	15.3	79,800	4.7	60,700	23.4	66,000	4.3	56,000	17.1	51,700	3.5
	Part		20,400	23.7	28,300	8.0	27,000	54.2	22,100	5.9	22,700	42.0	19,400	5.2

Cooling capacities based upon 80.6°F DB, 66.2°F WB entering air temperature
 Heating capacities based upon 68°F DB, 59°F WB entering air temperature
 All ratings based upon 208V operation

6/13/24

Energy Star Compliance Table

Model	Tier 3	
	Ground Water	Ground Loop
024	E	E
036	E	E
048	E	E
060	E	E

5/14/24

Energy Star Rating Criteria

In order for water-source heat pumps to be Energy Star rated they must meet or exceed the minimum efficiency requirements listed below. Tier 3 represents the current minimum efficiency water source heat pumps must have in order to be Energy Star rated.

Tier 3: 1/1/2012 - No Effective End Date Published

Water-to-Air	EER	COP
Ground Loop	17.1	3.6
Ground Water	21.1	4.1
Water-to-Water		
Ground Loop	16.1	3.1
Ground Water	20.1	3.5



Physical Data

Model		024	036	048	060
Compressor (1 each)		Variable Speed Scroll			
Factory Charge R454B, oz [kg]	Vertical	64 [1.81]	64 [1.81]	95 [2.69]	110 [3.12]
Factory Charge R454B, oz [kg]	Horizontal	60 [1.70]	60 [1.70]	91 [2.58]	118 [3.35]
ECM Blower Motor & Blower		Variable Speed			
Blower Motor Type/Speeds	ECM				
Blower Motor- hp [W]	ECM	1/2 [373]	1/2 [373]	1 [746]	1 [746]
High Static Blower Motor - hp [W]	ECM	1 [746]	1 [746]	n/a	n/a
Blower Wheel Size (Dia x W), in. [mm]	ECM	11 x 10 [279 x 254]	11 x 10 [279 x 254]	11 x 10 [279 x 254]	11 x 10 [279 x 254]
High Static Blower Wheel Size - [Dia. x W], in. [mm]	ECM	11 x 10 [279 x 254]	11 x 10 [279 x 254]	n/a	n/a
Coax and Water Piping					
Water Connections Size - Swivel - in [mm]		1" [25.4]	1" [25.4]	1" [25.4]	1" [25.4]
HWG Connection Size - Female Sweat I.D. - in [mm]		1/2" [12.7]	1/2" [12.7]	1/2" [12.7]	1/2" [12.7]
Coax & Piping Water Volume - gal [l]		1.3 [4.9]	1.3 [4.9]	2.3 [8.7]	2.3 [8.7]
Vertical					
Air Coil Dimensions (H x W), in. [mm]		32 x 25 [813 x 635]	32 x 25 [813 x 635]	32 x 25 [813 x 635]	36 x 25 [914 x 635]
Air Coil Total Face Area, ft2 [m2]		5.6 [0.570]	5.6 [0.570]	5.6 [0.570]	6.3 [0.641]
Air Coil Tube Size, in [mm]		3/8 [9.5]	3/8 [9.5]	3/8 [9.5]	3/8 [9.5]
Air Coil Number of rows		3	3	3	4
Reheat Coil Dimensions (H x W), in. [mm] (MHGR Only)		23 x 30 [584 x 762]	23 x 30 [584 x 762]	23 x 30 [584 x 762]	23 x 34 [584 x 864]
Filter Standard - 2" [51mm] Pleated MERV11 Throwaway, in [mm]		32 x 30 [813 x 762]	32 x 30 [813 x 762]	32 x 30 [813 x 762]	36 x 30 [914 x 762]
Weight - Operating, lb [kg]		331 [150]	331 [150]	354 [161]	372 [169]
Weight - Packaged, lb [kg]		351 [159]	351 [159]	374 [170]	392 [178]
Horizontal					
Air Coil Dimensions (H x W), in. [mm]		20 x 40 [508 x 1016]	20 x 40 [508 x 1016]	20 x 40 [508 x 1016]	20 x 45 [508 x 1143]
Air Coil Total Face Area, ft2 [m2]		5.6 [0.570]	5.6 [0.570]	5.6 [0.570]	6.3 [0.641]
Air Coil Tube Size, in [mm]		3/8 [9.5]	3/8 [9.5]	3/8 [9.5]	3/8 [9.5]
Air Coil Number of rows		3	3	3	4
Filter Standard - 2" [51mm] Pleated MERV11 Throwaway, in [mm]		1 - 20 x 20 [508 x 508] 1 - 20 x 22 [508 x 559]	1 - 20 x 20 [508 x 508] 1 - 20 x 22 [508 x 559]	1 - 20 x 20 [508 x 508] 1 - 20 x 22 [508 x 559]	1 - 20 x 25 [508 x 635] 1 - 20 x 22 [508 x 559]
Weight - Operating, lb [kg]		365 [166]	365 [166]	388 [176]	402 [182]
Weight - Packaged, lb [kg]		395 [179]	395 [179]	418 [190]	432 [196]

5/10/24

Dimensional Data - Vertical

Top Air Discharge

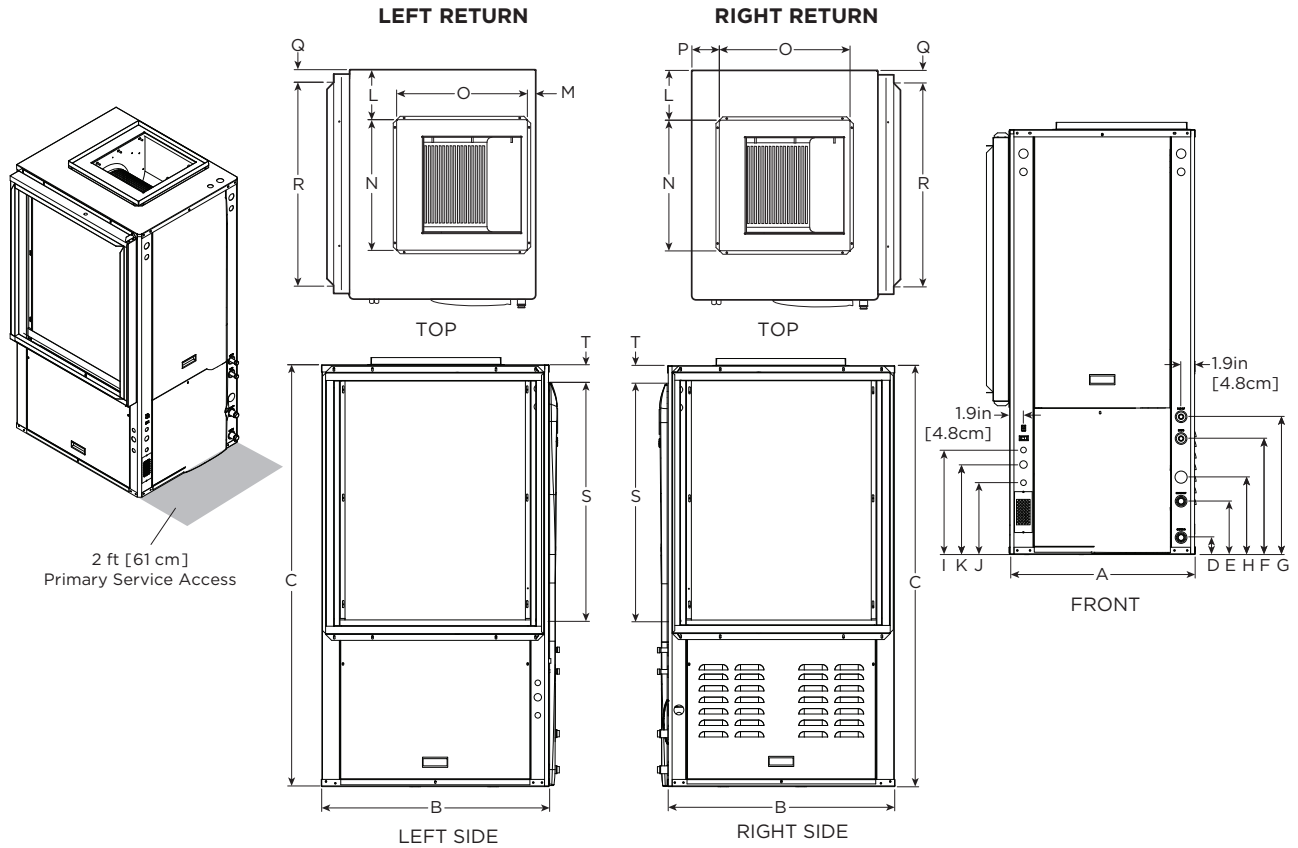

Vertical Top Flow Model	Overall Cabinet			Water Connections							Electrical Connections			Discharge Connection duct flange installed (± 0.10 in.)					Return Connection using std deluxe filter rack (± 0.10)				
	A	B	C	D	E	F	G	H	Loop Water FPT	HWG (O.D.)	I 1/2" cond Low Voltage	J 1/2" cond Ext Pump	K 3/4" cond Power Supply	L	M	N Supply Width	O Supply Depth	P	Q Return Depth	R Return Depth	S Return Height	T	
	Width	Depth	Height	Loop In	Loop Out	HWG In	HWG Out	Condensate															
024-036	in.	25.6	31.6	54.4	2.3	7.3	15.9	18.9	10.6	1"	1/2" stub	14.3	9.8	12.3	6.9	1.1	18.0	18.0	3.8	1.7	28.1	30.0	1.7
	cm.	65.0	80.3	138.2	5.8	18.5	40.4	48.0	26.9	Swivel		36.3	24.9	31.2	17.5	2.8	45.7	45.7	9.7	4.3	71.4	76.2	4.3
048	in.	25.6	31.6	54.4	2.3	7.3	15.9	18.9	10.6	1"	1/2" stub	14.3	9.8	12.3	6.9	1.1	18.0	18.0	3.8	1.7	28.1	30.0	1.7
	cm.	65.0	80.3	138.2	5.8	18.5	40.4	48.0	26.9	Swivel		36.3	24.9	31.2	17.5	2.8	45.7	45.7	9.7	4.3	71.4	76.2	4.3
060	in.	25.6	31.6	58.4	2.3	7.3	15.9	18.9	10.6	1"	1/2" stub	14.3	9.8	12.3	6.9	1.1	18.0	18.0	3.8	1.7	28.1	34.0	1.7
	cm.	65.0	80.3	148.3	5.8	18.5	40.4	48.0	26.9	Swivel		36.3	24.9	31.2	17.5	2.8	45.7	45.7	9.7	4.3	71.4	86.4	4.3

Condensate is 3/4" PVC female glue socket and is switchable from side to front
 Unit shipped with deluxe 2" (field adjustable to 1") duct collar/filter rack extending from unit 3.25" and is suitable for duct connection.
 Discharge flange is field installed and extends 1" [25.4mm] from cabinet
 Decorative molding and/or water connections extend 1.2" [30.5mm] beyond front of cabinet.
 Louvered vents in the compressor section right side access panel extend 1/2" [12.7 mm] from side of cabinet. Allow clearance for venting.

05/10/24

Dimensional Data - Vertical

Bottom Air Discharge

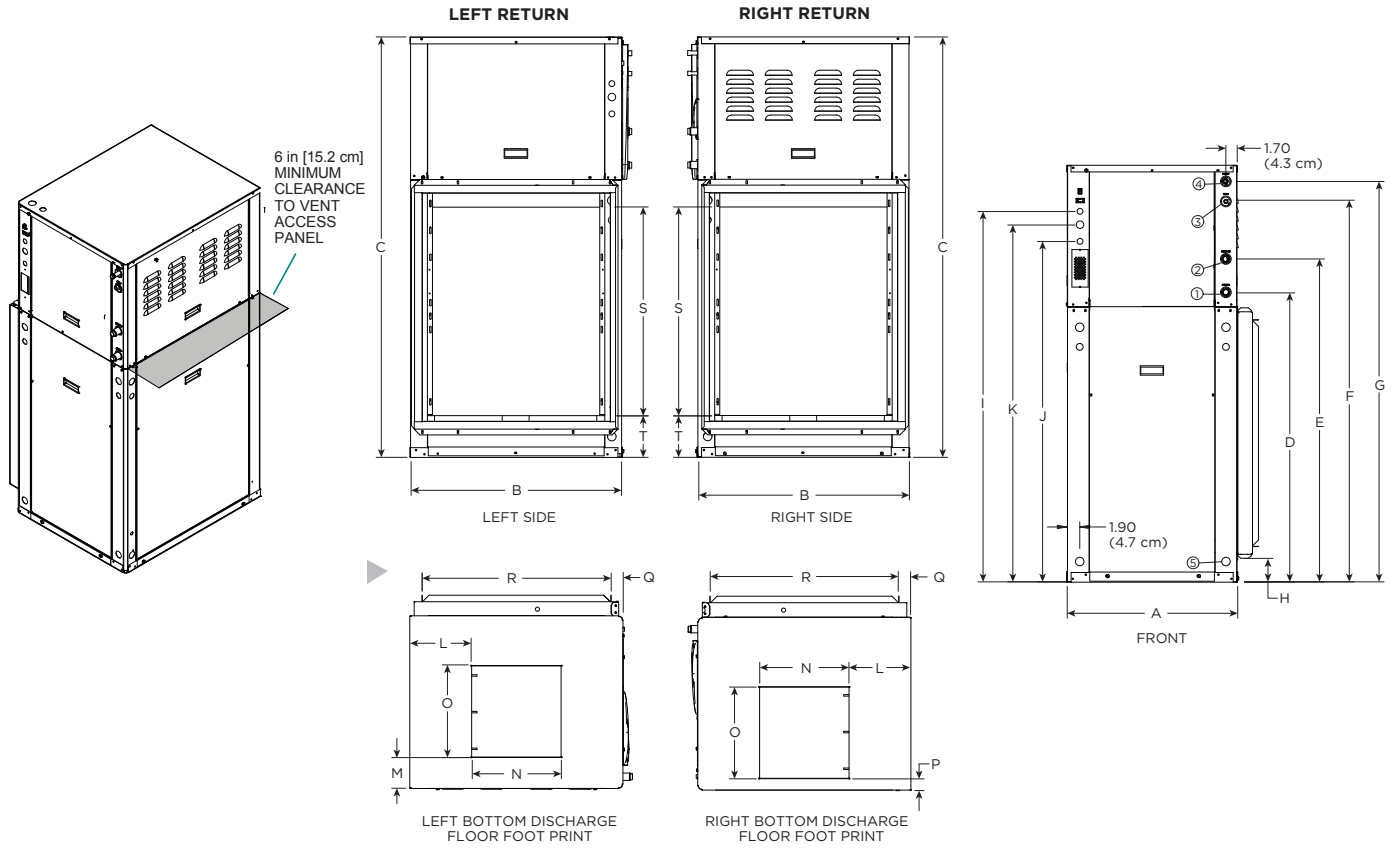

Bottomflow Models	Overall Cabinet			Water Connections							Electrical Knockouts			Discharge Connection duct flange installed (± 0.10 in.)					Return Connection using std deluxe filter rack (± 0.10)			
	A	B	C	1	2	3	4	5	Loop Water FPT	HWG (O.D.)	I 1/2" cond	J 1/2" cond	K 3/4" cond	L	M	N	O	P	Q	R	S	T
	Width	Depth	Height	D In	E Out	F HWG In	G HWG Out	H Condensate			Low Voltage	Ext Pump	Power Supply			Supply Width	Supply Depth		Return Depth	Return Height		
024-060	in. cm.	25.5 64.8	31.5 80.0	62.5 158.8	43.4 110.2	48.4 122.9	57.0 144.8	60.0 152.4	3.1 7.9	1" Swivel	51.1 129.8	55.6 141.2	53.6 136.1	9.1 23.1	4.8 12.2	13.4 34.0	13.6 34.5	1.7 4.3	1.8 4.6	28.1 71.4	34.0 86.4	5.6 14.2

Condensate is 3/4" PVC female glue socket and is switchable from side to front

5/10/24

Unit shipped with deluxe 2" (field adjustable to 1") duct collar/filter rack extending from unit 3.25" and is suitable for duct connection.

Decorative molding and/or water connections extend 1.2" [30.5mm] beyond front of cabinet.

Louvered vents in the compressor section right side access panel extend 1/2" [12.7 mm] from side of cabinet. Allow clearance for venting.

Dimensional Data - Vertical

Rear Air Discharge

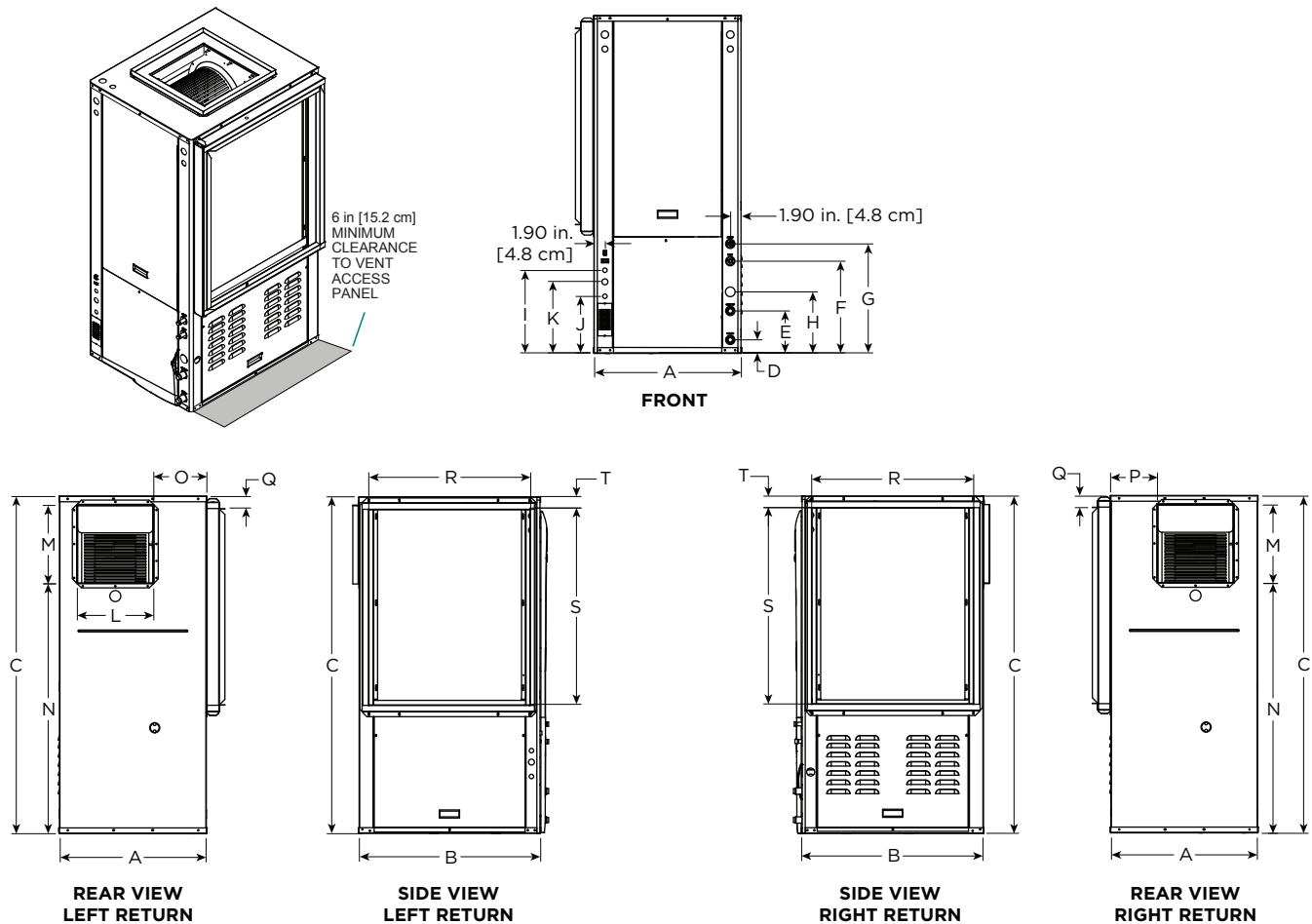

Vertical Rear Discharge Model	Overall Cabinet			Water Connections						Electrical Connections			Discharge Connection duct flange installed (±0.10 in)					Return Connection using std deluxe filter rack (±0.10 in)					
	A Width	B Depth	C Height	D Loop In	E Loop Out	F HWG In	G HWG Out	H Cond- ensate	Loop Water FPT	HWG Sweat (I.D.)	I 1/2 in. cond Low Voltage	J 1/2 in. cond Ext Pump	K 3/4 in. cond Power Supply	L Supply Width	M Supply Depth	N	O	P	Q	R Return Depth	S Return Height	T	
036	in.	25.6	31.6	54.4	2.3	7.3	15.9	18.9	10.6	1 in.	1/2 in.	14.3	9.8	12.3	13.3	13.6	39.4	9.1	8.1	1.7	28.1	30.0	1.7
	cm.	65.0	80.3	138.2	5.8	18.5	40.4	48.0	26.9	Swivel	Female	36.3	24.9	31.2	33.8	34.5	100.1	23.1	20.6	4.3	71.4	76.2	4.3
048	in.	25.6	31.6	54.4	2.3	7.3	15.9	18.9	10.6	1 in.	1/2 in.	14.3	9.8	12.3	13.3	13.6	39.4	9.1	8.1	1.7	28.1	30.0	1.7
	cm.	65.0	80.3	138.2	5.8	18.5	40.4	48.0	26.9	Swivel	Female	36.3	24.9	31.2	33.8	34.5	100.1	23.1	20.6	4.3	71.4	76.2	4.3
060	in.	25.6	31.6	58.4	2.3	7.3	15.9	18.9	10.6	1 in.	1/2 in.	14.3	9.8	12.3	13.3	13.6	43.4	9.1	8.1	1.7	28.1	34.0	1.7
	cm.	65.0	80.3	148.3	5.8	18.5	40.4	48.0	26.9	Swivel	Female	36.3	24.9	31.2	33.8	34.5	110.2	23.1	20.6	4.3	71.4	86.4	4.3

Condensate is 3/4 in. PVC female glue socket and is switchable from side to front
 Unit shipped with deluxe 2 in. (field adjustable to 1 in.) duct collar/filter rack extending from unit 3.25 in. and is suitable for duct connection.
 Discharge flange is field installed and extends 1 in. [25.4mm] from cabinet
 Decorative molding and/or water connections extend 1.2 in. [30.5mm] beyond front of cabinet.
 Louvered vents in the compressor section right side access panel extend 1/2 in. [12.7 mm] from side of cabinet. Allow 6" clearance for venting.

6/29/12

Dimensional Data - Horizontal

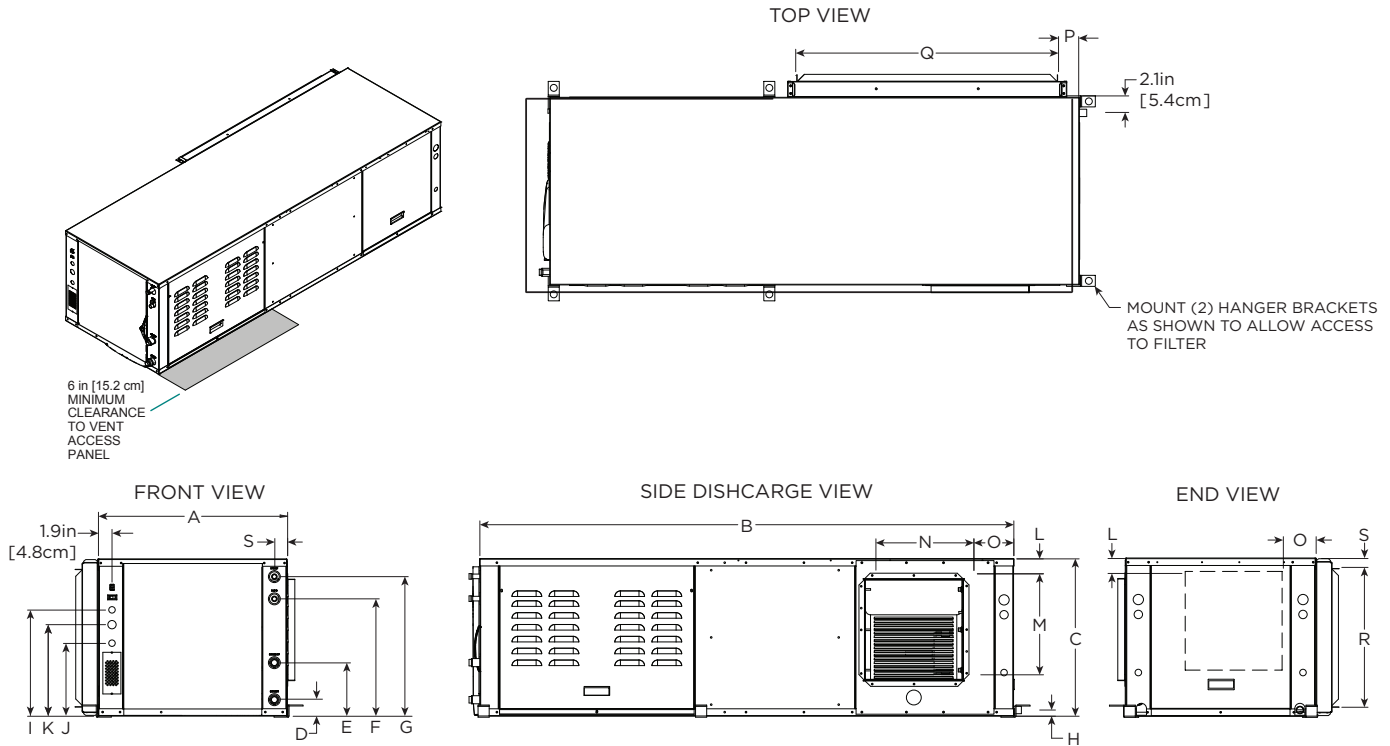

AS SHOWN LR UNIT (RR UNIT ON OPPOSITE SIDE—SAME DIMENSIONS)

Horizontal Models	Overall Cabinet			Water Connections								Electrical Connections			Discharge Connection duct flange installed (± 0.10 in.)				Return Connection using std deluxe filter rack (± 0.10)			
	A	B	C	D	E	F	G	H	Loop Water FPT	HWG Sweat (O.D.)	I	J	K	L	M	N	O	P	Q	R	S	
	Width	Depth	Height	In	Out	HWG In	HWG Out	Condensate			1/2" cond	1/2" cond	3/4" cond		Supply Height	Supply Depth			Return Depth	Return Height		
024-036	in.	25.6	77.0	21.3	2.3	7.3	15.9	18.9	0.8	1" Swivel	1/2" stub	14.3	9.8	12.3	SEE CHART	13.6	13.2	SEE CHART	2.8	40.4	18.9	1.3
	cm.	65.0	195.6	54.1	5.8	18.5	40.4	48.0	2.0			36.3	24.9	31.2		34.5	33.5		7.1	102.6	48.0	3.3
048	in.	25.6	77.0	21.3	2.3	7.3	15.9	18.9	0.8	1" Swivel	1/2" stub	14.3	9.8	12.3	SEE CHART	13.6	13.2	SEE CHART	2.8	40.4	18.9	1.3
	cm.	65.0	195.6	54.1	5.8	18.5	40.4	48.0	2.0			36.3	24.9	31.2		34.5	33.5		7.1	102.6	48.0	3.3
060	in.	25.6	82.0	21.3	2.3	7.3	15.9	18.9	0.8	1" Swivel	1/2" stub	14.3	9.8	12.3	SEE CHART	13.6	13.2	SEE CHART	2.8	45.4	18.9	1.3
	cm.	65.0	208.3	54.1	5.8	18.5	40.4	48.0	2.0			36.3	24.9	31.2		34.5	33.5		7.1	115.3	48.0	3.3

Condensate is 3/4" PVC female glue socket and is switchable from side to front

5/10/24

Unit shipped with deluxe 2" (field adjustable to 1") duct collar/filter rack extending from unit 3.25" and is suitable for duct connection.

Discharge flange is field installed and extends 1" [25.4mm] from cabinet

Decorative molding and/or water connections extend 1.2" [30.5mm] beyond front of cabinet.

Louvered vents in the compressor section right side access panel extend 1/2" [12.7 mm] from side of cabinet. Allow clearance for venting.

Units Not Shown Above	L	O	
Right Return End Discharge	in	2.8	4.6
	cm	7.1	11.8
Right Return Side Discharge	in	4.9	6.9
	cm	12.4	17.5
Left Return End Discharge	in	4.9	7.6
	cm	12.4	19.4
Left Return Side Discharge	in	2.8	6.9
	cm	7.1	17.5

Electrical Data

Model	Rated Voltage	Voltage Min/Max	COMP MRC	COMP MOC	Drive RLA	Drive Internal Fuse	HWG Pump FLA	Ext Loop FLA	Blower Motor FLA	Total Unit FLA	Minimum Circuit Amp	Max Fuse HACR Breaker
024-036	208-230/60/1	187/253	22.0	17.0	22.0	30.0	0.4	5.4	4.0	31.8	37.3	40
*036	208-230/60/1	187/253	22.0	17.0	22.0	30.0	0.4	5.4	7.0	34.8	40.3	45
048	208-230/60/1	187/253	28.0	22.0	28.0	35.0	0.4	5.4	7.0	40.8	47.8	50
060	208-230/60/1	187/253	33.0	27.0	33.0	40.0	0.4	5.4	7.0	45.8	54.1	60

*With optional 1 HP ECM motor
 Rated Voltage of 208/230/60/1
 HACR circuit breaker in USA only
 All fuses Class RK-5

5/13/24

Auxiliary Heat Ratings

Model	KW		Stages	BTU/HR		Min CFM	Variable Speed Compatibility		
	208V	230V		208V	230V		024-036	048	060
EAL(H)10	7.2	9.6	2	24,600	32,700	1100	•	•	•
EAL(H)15	10.8	14.4	3	36,900	49,100	1250	•	•	•
EAL(H)20	14.4	19.2	4	49,200	65,500	1500		•	•

Air flow level for auxiliary heat (Aux) must be above the minimum cfm in this table
 Order the "H" part number when installed on horizontal and vertical rear discharge units

5/10/24

Auxiliary Heat Electrical Data

Model	Supply Circuit	Heater Amps		Min Circuit Amp		Max Fuse (USA)		Max Fuse (CAN)		Max CKT BRK	
		208 V	240 V	208 V	240 V	208 V	240 V	208 V	240 V	208 V	240 V
EAL(H)10*	Single	34.7	40	53.3	60	60	60	60	60	60	60
EAL(H)15*	Single	52.0	60	75	85	80	90	80	90	70	100
	L1/L2	34.7	40	53.3	60	60	60	60	60	60	60
	L3/L4	17.3	20	21.7	25	25	25	25	25	20	30
EAL(H)20*	Single	69.3	80	96.7	110	100	110	100	110	100	100
	L1/L2	34.7	40	53.3	60	60	60	60	60	60	60
	L3/L4	34.7	40	43.3	50	45	50	45	50	40	50

All heaters rated single phase 60 cycle and include unit fan load
 All fuses type "D" time delay (or HACR circuit breaker in USA)

11/30/17

Blower Performance Data

Variable Speed Air Flow

Model	Max ESP	Speed 1	Speed 2	Speed 3	Speed 4	Speed 5	Speed 6	Speed 7	Speed 8	Speed 9	Speed 10	Speed 11	Speed 12
024***	0.50	285	380 G	525 L	675	815	980	1100 H	1220 Aux				
036	0.50	285	380 G	525 L	675	815	980	1100	1220	1330	1440 H	1540 Aux	1575
036 w/1hp*	0.75	480	565 G	665 L	761	870	1000	1100	1200	1300	1410 H	1520 Aux	1630
048	0.75	475	620 G	730 L	850	1020	1140	1270	1400	1520	1650 H	1790 Aux	1925
060	0.75	400	600 G	830 L	1050	1230	1400	1560	1700	1870	2010 H	2140 Aux	2265
**VS Compressor Speed				1-2	3-4		5-6	7-8		9-10	11-12		

5/10/24

** VS Compressor speed is given for the factory default cfm settings. When the cfm default settings are changed it will change the relationship to the compressor speed that is shown in the table. In cooling mode compressor speeds 10-12 are only available when SuperBoost mode is selected at the thermostat.

* optional 1 HP ECM

Factory settings are at recommended G, L, H and Aux positions

"G" may be located anywhere within the airflow table

"L" setting should be located within the boldface CFM range

"H" setting MUST be located within the shaded CFM range

"Aux" setting MUST be equal to or greater than "H" setting

"Aux" setting MUST be equal to or greater than the minimum allowable CFM for the auxiliary heater kit (see auxiliary heat ratings table)

CFM is controlled within 5% up to the maximum ESP

Max ESP includes allowance for wet coil and standard filter

***Operation for 024 model above Speed 8 is NOT recommended

Setting Blower Speed - Variable Speed ECM

The ABC board's Yellow Config LED will flash the current ECM blower speed selections for G, low, and high continuously with a short pause in between. The speeds can also be confirmed with the AID Tool under the Setup/ECM Setup screen. The Aux will not be flashed but can be viewed in the AID Tool. The ECM blower motor speeds can be field adjusted with or without using an AID Tool.

Variable speed ECM Setup without an AID Tool

The blower speeds for G only, Low (Y1), and High (Y2/Aux) can be adjusted directly at the Aurora ABC board which utilizes the push button (SW1) on the ABC board. This procedure is outlined in the ECM Configuration Mode portion of the Aurora 'Base' Control System section. The Aux cannot be set manually without an AID Tool.

Variable speed ECM Setup with an AID Tool

A much easier method utilizes the AID Tool to change the airflow using the procedure below. First navigate to the Setup screen and then select ECM Setup. This screen displays the current ECM settings. It allows the technician to enter the setup screens to change the ECM settings. Change the highlighted item using the ◀ and ▶ buttons and then press the ◻ button to select the item.

Selecting YES will enter ECM speed setup, while selecting NO will return to the previous screen.

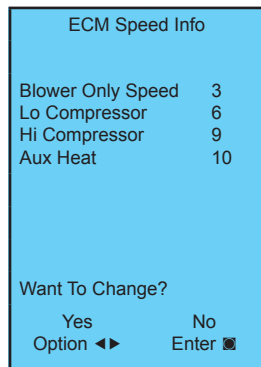

ECM Speed Setup - These screens allow the technician to select the G, low, high, and auxiliary heat blower speed for the ECM blower motor. Change the highlighted item using the ▲ and ▼ buttons. Press the ◻ button to select the speed.

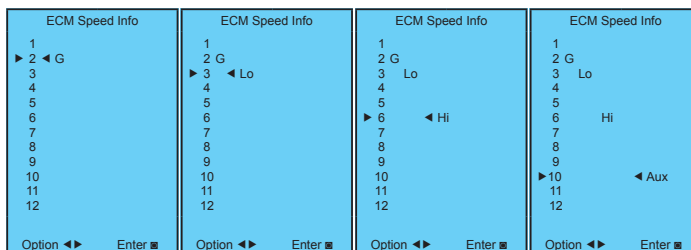

After the auxiliary heat speed setting is selected the AID Tool will automatically transfer back to the ECM Setup screen.

Cooling Airflow Setup - These screens allow the technician to select -15%, -10%, -5%, None or +5% change from the heating airflow. Change the adjustment percentage using the ▲ and ▼ buttons. Press the ◻ button to save the change.

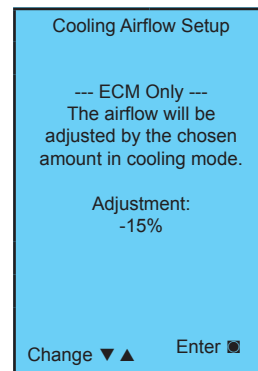
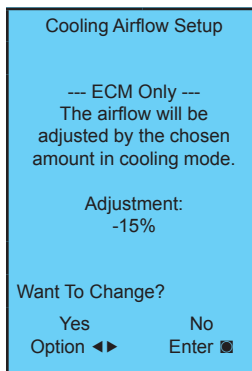

Reference Calculations

Heating Calculations:	Cooling Calculations:
$LWT = EWT - \frac{HE}{gpm \times 500}$	$LWT = EWT + \frac{HR}{gpm \times 500}$
$LAT = EAT + \frac{HC}{cfm \times 1.08}$	$LAT (DB) = EAT (DB) - \frac{SC}{cfm \times 1.08}$
$TH = HC + HW$	$LC = TC - SC$
	$S/T = \frac{SC}{TC}$

Legend and Notes

Abbreviations and Definitions

cfm = airflow, cubic feet/minute	HWC = hot water generator capacity, MBtu/h
EWT = entering water temperature, Fahrenheit	EER = Energy Efficient Ratio
gpm = water flow in gallons/minute	= Btu output/Watt input
WPD = water pressure drop, psi and feet of water	COP = Coefficient of Performance
EAT = entering air temperature, Fahrenheit (dry bulb/wet bulb)	= Btu output/Btu input
HC = air heating capacity, MBtu/h	LWT = leaving water temperature, °F
TC = total cooling capacity, MBtu/h	LAT = leaving air temperature, °F
SC = sensible cooling capacity, MBtu/h	TH = total heating capacity, MBtu/h
kW = total power unit input, kilowatts	LC = latent cooling capacity, MBtu/h
HR = total heat of rejection, MBtu/h	S/T = sensible to total cooling ratio
HE = total heat of extraction, MBtu/h	

Notes to Performance Data Tables

The following notes apply to all performance data tables:

- Performance ratings are based on 80°F DB/67°F WB EAT for cooling and 70°F DB EAT for heating.
- Three flow rates are shown for each unit. The lowest flow rate shown is used for geothermal open loop/well water systems with a minimum of 50°F EWT. The middle flow rate shown is the minimum geothermal closed loop flow rate. The highest flow rate shown is optimum for geothermal closed loop systems and the suggested flow rate for boiler/tower applications.
- The hot water generator numbers are based on a flow rate of 0.4 gpm/ton of rated capacity with an EWT of 90°F.
- Entering water temperatures below 40°F assumes 15% antifreeze solution.
- For non-standard EAT conditions, apply the appropriate Correction Factor tables.
- Interpolation between EWT, gpm, and cfm data is permissible, extrapolation is not.

Operating Limits

Operating Limits	Cooling		Heating	
	(°F)	(°C)	(°F)	(°C)
Air Limits				
Min. Ambient Air	45	7.2	45	7.2
Rated Ambient Air	80	26.7	70	21.1
Max. Ambient Air	100	37.8	85	29.4
Min. Entering Air	50	10.0	40	4.4
Rated Entering Air db/wb	80.6/66.2	27/19	68	20.0
Max. Entering Air db/wb	110/83	43/28.3	80	26.7
Water Limits				
Min. Entering Water	30	-1.1	20	-6.7
Normal Entering Water	50-110	10-43.3	30-70	-1.1
Max. Entering Water	120	48.9	90	32.2

NOTE: Minimum/maximum limits are only for start-up conditions, and are meant for bringing the space up to occupancy temperature. Units are not designed to operate at the minimum/maximum conditions on a regular basis. The operating limits are dependent upon three primary factors: 1) water temperature, 2) return air temperature, and 3) ambient temperature. When any of the factors are at the minimum or maximum levels, the other two factors must be at the normal level for proper and reliable unit operation.

Antifreeze Corrections

Catalog performance can be corrected for antifreeze use. Please use the following table and note the example given.

Antifreeze Type	Antifreeze % by wt	Heating	Cooling	Pressure Drop
EWT - °F [°C]		30 [-1.1]	90 [32.2]	30 [-1.1]
Water	0	1.000	1.000	1.000
	10	0.973	0.991	1.075
Ethylene Glycol	20	0.943	0.979	1.163
	30	0.917	0.965	1.225
	40	0.890	0.955	1.324
	50	0.865	0.943	1.419
	10	0.958	0.981	1.130
Propylene Glycol	20	0.913	0.969	1.270
	30	0.854	0.950	1.433
	40	0.813	0.937	1.614
	50	0.770	0.922	1.816
	10	0.927	0.991	1.242
Ethanol	20	0.887	0.972	1.343
	30	0.856	0.947	1.383
	40	0.815	0.930	1.523
	50	0.779	0.911	1.639
	10	0.957	0.986	1.127
Methanol	20	0.924	0.970	1.197
	30	0.895	0.951	1.235
	40	0.863	0.936	1.323
	50	0.833	0.920	1.399



WARNING: Gray area represents antifreeze concentrations greater than 35% by weight and should be avoided due to the extreme performance penalty they represent.

Antifreeze Correction Example

Antifreeze solution is Propylene Glycol 20% by weight. Determine the corrected heating and cooling performance at 30°F and 90°F respectively as well as pressure drop at 30°F for a 036 operating at 100% capacity.

The corrected cooling capacity at 90°F would be: 35,200 Btu/h x 0.969 = 34,109 Btu/h

The corrected heating capacity at 30°F would be: 37,400 Btu/h x 0.913 = 34,146 Btu/h

The corrected pressure drop at 30°F and 11.5 gpm would be: 7.9 feet of head x 1.270 = 10.03 feet of head

Correction Factor Tables

Air Flow Corrections (Compressor Speeds 1-3)

Airflow		Cooling				Heating		
CFM Per Ton of Clg	% of Nominal	Total Cap	Sens Cap	Power	Heat of Rej	Htg Cap	Power	Heat of Ext
240	60	0.940	0.740	0.967	0.951	0.943	1.106	0.902
275	69	0.950	0.783	0.973	0.959	0.953	1.088	0.918
300	75	0.960	0.827	0.978	0.967	0.962	1.070	0.935
325	81	0.970	0.870	0.984	0.975	0.972	1.053	0.951
350	88	0.980	0.913	0.989	0.984	0.981	1.035	0.967
375	94	0.990	0.957	0.995	0.992	0.991	1.018	0.984
400	100	1.000	1.000	1.000	1.000	1.000	1.000	1.000
425	106	1.030	1.022	1.024	1.026	1.009	0.982	1.016
450	113	1.060	1.045	1.048	1.051	1.019	0.965	1.033
475	119	1.091	1.067	1.071	1.077	1.028	0.947	1.049
500	125	1.121	1.089	1.095	1.103	1.038	0.930	1.065
520	130	1.151	1.111	1.110	1.129	1.047	0.912	1.082

6/29/12

Air Flow Corrections (Compressor Speeds 4-12)

Airflow		Cooling				Heating		
CFM Per Ton of Clg	% of Nominal	Total Cap	Sens Cap	Power	Heat of Rej	Htg Cap	Power	Heat of Ext
240	60	0.928	0.747	0.936	0.929	0.961	1.097	0.938
275	69	0.940	0.789	0.946	0.941	0.967	1.081	0.948
300	75	0.952	0.831	0.957	0.953	0.974	1.064	0.959
325	81	0.964	0.873	0.968	0.965	0.980	1.048	0.969
350	88	0.976	0.916	0.979	0.976	0.987	1.032	0.979
375	94	0.988	0.958	0.989	0.988	0.993	1.016	0.990
400	100	1.000	1.000	1.000	1.000	1.000	1.000	1.000
425	106	1.020	1.023	1.004	1.018	1.010	0.966	1.018
450	113	1.056	1.042	1.008	1.035	1.020	0.932	1.036
475	119	1.072	1.079	1.011	1.053	1.029	0.898	1.054
500	125	1.087	1.095	1.015	1.070	1.039	0.865	1.071
520	130	1.099	1.113	1.019	1.088	1.049	0.831	1.089

6/14/12

Cooling Capacity Corrections

Entering Air WB °F	Total Clg Cap	Sensible Cooling Capacity Multipliers - Entering DB °F										Power Input	Heat of Rejection
		60	65	70	75	80	80.6	85	90	95	100		
55	0.898	0.723	0.866	1.048	1.185	*	*	*	*	*	*	0.985	0.913
60	0.912		0.632	0.880	1.078	1.244	1.260	*	*	*	*	0.994	0.927
63	0.945			0.768	0.960	1.150	1.175	*	*	*	*	0.996	0.954
65	0.976			0.694	0.881	1.079	1.085	1.270	*	*	*	0.997	0.972
66.2	0.983			0.655	0.842	1.040	1.060	1.232	*	*	*	0.999	0.986
67	1.000			0.616	0.806	1.000	1.023	1.193	1.330	1.480	*	1.000	1.000
70	1.053				0.693	0.879	0.900	1.075	1.205	1.404	*	1.003	1.044
75	1.168					0.687	0.715	0.875	1.040	1.261	1.476	1.007	1.141

NOTE: *Sensible capacity equals total capacity at conditions shown.

4/22/12

Heating Capacity Corrections

Ent Air DB °F	Heating Corrections		
	Htg Cap	Power	Heat of Ext
45	1.062	0.739	1.158
50	1.050	0.790	1.130
55	1.037	0.842	1.096
60	1.025	0.893	1.064
65	1.012	0.945	1.030
68	1.005	0.976	1.012
70	1.000	1.000	1.000
75	0.987	1.048	0.970
80	0.975	1.099	0.930

11/10/09

Heat of Extraction/Heat of Rejection

Model		GPM	Heat of Extraction (MBtuh)				GPM	Heat of Rejection (MBtuh)				
			30°F	50°F	70°F	90°F		30°F	50°F	70°F	90°F	110°F
024-036	Full Load	5.5	22.5	32.5	41.7	49.1	4.5	39.1	44.1	42.8	40.3	37.9
		8.0	23.2	33.9	43.3	51.2	7.0	39.4	44.7	43.0	41.1	38.5
		11.5	23.8	34.8	44.7	53.1	9.0	39.8	45.1	43.2	41.4	39.0
048	Full Load	6.5	27.9	38.5	52.5	60.1	5.5	47.9	53.7	51.4	48.5	54.1
		10.0	30.6	42.6	55.9	66.9	8.0	48.2	53.9	51.7	48.9	45.9
		13.5	31.7	44.3	58.9	71.4	10.5	48.7	54.2	51.9	49.2	46.2
060	Full Load	8.5	33.5	48.4	63.9	83.0	6.5	66.9	70.8	69.0	64.1	58.7
		13.0	36.9	51.9	68.4	84.3	10.0	67.3	71.2	69.2	64.3	59.2
		17.0	37.3	53.1	70.5	87.9	13.5	68.0	71.7	69.5	64.7	59.4

Note: operation not recommended in shaded areas.

5/13/24

Water Quality

Material		Copper	90/10 Cupronickel	316 Stainless Steel
pH	Acidity/Alkalinity	7 - 9	7 - 9	7 - 9
Scaling	Calcium and Magnesium Carbonate	(Total Hardness) less than 350 ppm	(Total Hardness) less than 350 ppm	(Total Hardness) less than 350 ppm
Corrosion	Hydrogen Sulfide	Less than 0.5 ppm (rotten egg smell appears at 0.5 ppm)	10 - 50 ppm	Less than 1 ppm
	Sulfates	Less than 125 ppm	Less than 125 ppm	Less than 200 ppm
	Chlorine	Less than 0.5 ppm	Less than 0.5 ppm	Less than 0.5 ppm
	Chlorides	Less than 20 ppm	Less than 125 ppm	Less than 300 ppm
	Carbon Dioxide	Less than 50 ppm	10 - 50 ppm	10 - 50 ppm
	Ammonia	Less than 2 ppm	Less than 2 ppm	Less than 20 ppm
	Ammonia Chloride	Less than 0.5 ppm	Less than 0.5 ppm	Less than 0.5 ppm
	Ammonia Nitrate	Less than 0.5 ppm	Less than 0.5 ppm	Less than 0.5 ppm
	Ammonia Hydroxide	Less than 0.5 ppm	Less than 0.5 ppm	Less than 0.5 ppm
	Ammonia Sulfate	Less than 0.5 ppm	Less than 0.5 ppm	Less than 0.5 ppm
	Total Dissolved Solids (TDS)	Less than 1000 ppm	1000 - 1500 ppm	1000 - 1500 ppm
	LSI Index	+0.5 to -0.5	+0.5 to -0.5	+0.5 to -0.5
Iron Fouling (Biological Growth)	Iron, FE ²⁺ (Ferrous) Bacterial Iron Potential	< 0.2 ppm	< 0.2 ppm	< 0.2 ppm
	Iron Oxide	Less than 1 ppm, above this level deposition will occur	Less than 1 ppm, above this level deposition will occur	Less than 1 ppm, above this level deposition will occur
Erosion	Suspended Solids	Less than 10 ppm and filtered for max. of 600 micron size	Less than 10 ppm and filtered for max. of 600 micron size	Less than 10 ppm and filtered for max. of 600 micron size
	Threshold Velocity (Fresh Water)	< 6 ft/sec	< 6 ft/sec	< 6 ft/sec

NOTES: Grains = ppm divided by 17
mg/L is equivalent to ppm

2/22/12

Water Quality

It is the responsibility of the system designer and installing contractor to ensure that acceptable water quality is present and that all applicable codes have been met in these installations. Failure to adhere to the guidelines in the water quality table could result in loss of warranty. In ground water situations where scaling could be heavy or where biological growth such as iron bacteria will be present, a closed loop system is recommended. The heat exchanger coils in ground water systems may, over a period of time, lose heat exchange capabilities due to a buildup of mineral deposits inside. These can be cleaned, but only by a qualified service mechanic, as special solutions and pumping equipment are required. Hot water generator coils can likewise become scaled and possibly plugged. In areas with extremely hard water, the owner should be informed that the heat exchanger may require occasional flushing.

Heat pumps with cupronickel heat exchangers are recommended for open loop applications due to the increased resistance to build-up and corrosion, along with reduced wear caused by acid cleaning.

Water Treatment

Do not use untreated or improperly treated water. Equipment damage may occur. The use of improperly treated or untreated water in this equipment may result in scaling, erosion, corrosion, algae or slime. Purchase of a pre-mix antifreeze could significantly improve system reliability if the water quality is

controlled and there are additives in the mixture to inhibit corrosion. There are many examples of such fluids on the market today such as Environol™ 1000 (pre-mix ethanol), and others. The services of a qualified water treatment specialist should be engaged to determine what treatment, if any, is required. The product warranty specifically excludes liability for corrosion, erosion or deterioration of equipment.

The heat exchangers and water lines in the units are copper or cupronickel tube. There may be other materials in the buildings piping system that the designer may need to take into consideration when deciding the parameters of the water quality. If antifreeze or water treatment solution is to be used, the designer should confirm it does not have a detrimental effect on the materials in the system.

Contaminated Water

In applications where the water quality cannot be held to prescribed limits, the use of a secondary or intermediate heat exchanger is recommended to separate the unit from the contaminated water. The table above outlines the water quality guidelines for unit heat exchangers. If these conditions are exceeded, a secondary heat exchanger is required. Failure to supply a secondary heat exchanger where needed will result in a warranty exclusion for primary heat exchanger corrosion or failure.

Operating Parameters

024 - Comp Speed 8 - 850 CFM

Entering Water Temp °F	Water Flow	Cooling -- No Hot Water Generation					
		Suction Pressure psig	Discharge Pressure psig	Superheat	Subcooling	Water Temp Rise °F	Air Temp Drop °F DB
30	8.0	109-114	116-126	6-10	8-12	6-10	15-20
50	8.0	128-133	162-172	6-10	6-10	5-8	20-25
70	8.0	130-135	225-232	8-12	6-10	5-8	20-25
90	8.0	134-139	300-310	6-10	6-10	5-8	18-23
110	8.0	136-141	442-452	6-10	8-12	5-9	16-21

6/17/24

024 - Comp Speed 12 - 1350 CFM

Entering Water Temp °F	Water Flow	Heating -- No Hot Water Generation					
		Suction Pressure psig	Discharge Pressure psig	Superheat	Subcooling	Water Temp Drop °F	Air Temp Rise °F DB
30	9.0	66-71	254-264	6-16	6-11	3-7	17-22
50	9.0	91-96	290-300	6-16	6-17	4-9	23-38
70	9.0	134-139	320-330	6-10	6-17	4-9	30-35
90	9.0	174-179	351-361	6-10	6-16	7-11	35-40

6/17/24

036 - Comp Speed 10 - 1300 CFM

Entering Water Temp °F	Water Flow	Cooling -- No Hot Water Generation					
		Suction Pressure psig	Discharge Pressure psig	Superheat	Subcooling	Water Temp Rise °F	Air Temp Drop °F DB
30	9	103-108	129-139	17-25	8-13	6-10	15-20
50	9	124-129	175-185	5-12	5-10	6-10	20-25
70	9	128-134	242-249	5-12	5-10	6-10	20-25
90	9	137-142	298-318	5-10	9-14	6-10	18-23
110	9	139-144	457-467	5-10	9-14	5-9	16-21

6/17/24

036 - Comp Speed 12 - 1500 CFM

Entering Water Temp °F	Water Flow	Heating -- No Hot Water Generation					
		Suction Pressure psig	Discharge Pressure psig	Superheat	Subcooling	Water Temp Drop °F	Air Temp Rise °F DB
30	11.5	66-71	254-264	6-16	6-11	3-7	17-22
50	11.5	91-96	290-300	6-16	6-17	4-9	23-38
70	11.5	134-139	320-330	6-10	6-17	4-9	30-35
90	11.5	174-179	351-361	6-10	6-16	7-11	35-40

6/17/24

048 - Comp Speed 10 - 1400 CFM

Entering Water Temp °F	Water Flow	Cooling -- No Hot Water Generation					
		Suction Pressure psig	Discharge Pressure psig	Superheat	Subcooling	Water Temp Rise °F	Air Temp Drop °F DB
30	10.5	113-118	144-154	17-22	9-14	8-13	19-25
50	10.5	130-135	184-194	10-12	6-11	8-13	19-25
70	10.5	132-137	252-259	10-12	6-11	8-13	18-24
90	10.5	133-138	319-324	10-12	8-12	7-12	17-23
110	10.5	135-140	451-462	10-12	10-12	7-12	17-23

6/17/24

048 - Comp Speed 12 - 1800 CFM

Entering Water Temp °F	Water Flow	Heating -- No Hot Water Generation					
		Suction Pressure psig	Discharge Pressure psig	Superheat	Subcooling	Water Temp Drop °F	Air Temp Rise °F DB
30	13.5	65-70	296-306	10-15	18-23	4-8	20-25
50	13.5	98-103	332-342	7-10	18-23	5-9	28-33
70	13.5	132-137	368-378	7-11	18-23	8-12	34-39
90	13.5	174-179	413-423	7-10	18-23	9-13	36-44

6/17/24

060 - Comp Speed 10 - 1800 CFM

Entering Water Temp °F	Water Flow	Cooling -- No Hot Water Generation					
		Suction Pressure psig	Discharge Pressure psig	Superheat	Subcooling	Water Temp Rise °F	Air Temp Drop °F DB
30	13.5	112-117	156-166	20-24	5-10	8-12	19-25
50	13.5	124-129	190-200	6-10	8-12	8-12	19-25
70	13.5	128-133	255-262	6-10	8-13	8-12	19-25
90	13.5	137-142	333-343	6-10	11-15	8-12	19-25
110	13.5	139-144	343-353	6-10	15-19	8-12	19-25

6/17/24

060 - Comp Speed 12 - 2200 CFM

Entering Water Temp °F	Water Flow	Heating -- No Hot Water Generation					
		Suction Pressure psig	Discharge Pressure psig	Superheat	Subcooling	Water Temp Drop °F	Air Temp Rise °F DB
30	17.0	64-69	270-280	6-10	8-12	4-8	20-26
50	17.0	101-106	305-315	6-10	10-15	4-8	24-30
70	17.0	129-134	339-349	6-10	13-18	6-10	32-38
90	17.0	169-174	377-387	6-10	13-18	8-12	39-45

6/17/24

Pressure Drop

Model	GPM	Pressure Drop (psi)				
		30° F	50° F	70°	90° F	110° F
024-036	11.5	3.60	3.30	3.10	2.90	2.70
	9.0	2.30	2.10	2.00	1.90	1.70
	7.0	1.50	1.40	1.30	1.20	1.10
	6.0	1.20	1.15	1.10	1.05	1.00
	4.5	0.70	0.66	0.64	0.60	0.55
048	13.5	4.60	4.40	4.10	3.80	3.50
	10.5	2.90	2.70	2.50	2.30	2.20
	7.5	1.70	1.60	1.50	1.40	1.30
	6.0	1.20	1.10	1.00	0.96	0.91
	4.0	0.62	0.61	0.60	0.58	0.56
060	17.0	6.40	6.00	5.60	5.20	4.80
	13.5	4.10	3.80	3.60	3.30	3.10
	9.5	2.20	2.10	2.00	1.80	1.70
	7.5	1.70	1.60	1.50	1.40	1.30
	5.0	0.68	0.62	0.58	0.55	0.53

5/10/24

Operation Logic

Heating Mode

When the variable speed controls determine that heating is needed in the space the blower will be turned on, the compressor will be ramped to speed 6 and the loop pump will be started. The compressor will continue to run at speed 6 for 60 seconds for oil circulation. During the 60 second oil circulation the controls will calculate what speed the compressor will need to operate at to maintain the set point in the space. If the compressor is operating at speed 12 and the unit is unable to maintain set point the controls will stage on the electric heat. Electric heat will not operate unless the compressor is already running at speed 12. Every 30 minutes if the compressor has been operating lower than speed 6, the controls will increase the compressor to speed 6 for one minute for oil circulation.

Cooling Mode

When the variable speed controls determine that cooling is needed in the space the blower will be turned on, the reversing valve will be enabled, the compressor will be ramped to speed 6, and the loop pump will be started. The compressor will continue to run at speed 6 for 60 seconds for oil circulation. During the 60 second oil circulation the controls will calculate what speed the compressor will need to operate at to maintain the set point in the space. The compressor will be limited to a maximum of speed 9 for cooling. If additional capacity is needed SuperBoost mode can be enabled from the thermostat allowing the compressor to run at speeds higher than 9 for a period of 24 hours. Every 30 minutes if the compressor has been operating lower than speed 6, the controls will increase the compressor to speed 6 for one minute for oil circulation.

ECM Blower Motor

The variable speed controls will vary the ECM blower output to maintain optimum air flow at each of the 12 compressor speeds. If dehumidification mode is selected during the cooling operation the airflow will be varied to allow for maximum moisture removal.

Variable Speed Loop Pump

The variable speed controls will operate the variable speed loop pump similar to the way the ECM blower motor operates. The speed of the pump will be increased as the compressor speed is increased to maintain adequate water flow.

Safe Mode

The system has encountered an unsafe operating condition that prevents automatic speed control, e.g. lost a sensor signal. To avoid damage to the system, the drive is running the compressor at a fixed speed of 2400 rpm awaiting the problem to be solved and eventually returning to normal operation. If the problem cannot be solved the drive stops and issues an alarm. (See fault/alarm table.)

Derating

The VS compressor utilizes 'envelope control' to maintain performance within operational limits and improve reliability. To accomplish this, pressure sensors for discharge and suction pressure as well as hot gas temperature sensing are used to monitor the conditions in which the compressor operates. The envelope does vary based upon operating speed (rpm). When operating out of these limits the control will attempt to improve the situation by moderating the compressor speed for a larger envelope. When this occurs it can be observed on the Aurora control as an 'E' code. The control will automatically try to resolve the situation. If the situation progresses, a fault and lockout will be generated by the control.

Aurora Control System

Aurora Advanced VS Control

Aurora Advanced VS Control System is a complete residential and commercial comfort system that brings all aspects of the HVAC system into one cohesive module network. The Aurora Advanced VS Control features the Aurora Base Control (ABC) and the Aurora Expansion Board (AXB). The variable speed drive communicates to the Aurora Control and provides variable capacity and envelope control. The ABC features microprocessor control and HP, LP, loss of charge, condensate and freeze detection, over/under voltage faults, along with communicating thermostat capability for complete fault detection text at the thermostat. Aurora uses the Modbus communication protocol to communicate between modules. Each module contains the logic to control all features that are connected to the module. The ABC has two Modbus channels. The first channel is configured for connecting to devices such as a communicating thermostat, expansion board, or other devices. The second channel is configured for connecting the Aurora Interface Diagnostics Tool (AID Tool).

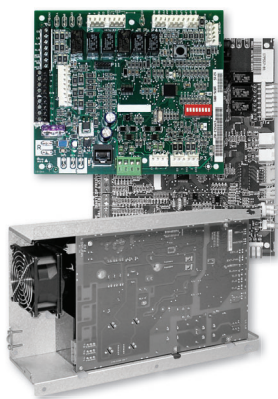



The Aurora AXB expands on the capability of the ABC control board. The additional features include active dehumidification, SuperBoost cooling mode, loop pump linking, intelligent hot water generator control, variable speed pump capability, standard energy, refrigeration, and optional performance monitoring. The AXB also features an optional second field configurable accessory relay, and two home automation inputs that are AID configurable for different types of alarms from sump pumps to home security. The Smart Grid input is AID configurable with many options to react to Utility controlled relay operation for On Peak optimization. The AXB also expands the communication capability for IntelliZone2 ready operation as well as other expansion with the ClimateTalk protocol.

Aurora Control Features	Description	Aurora Advanced VS
Advanced Microprocessor Features	Smart Grid, Home Automation Alarm Inputs, and Accessory2 Relay (HRV/ERV)	•
Advanced Hot Water Generator Control	Microprocessor and separate power relay for Hot Water Generator Pump with digital temperature monitoring and multiple HWG setpoint selection.	•
Advanced Speed Pump Control	Microprocessor and separate power relay for loop pump and inline circuit breakers and loop pump linking.	•
Variable Speed Pump	Capable of setup, monitoring and controlling a variable speed flow center.	•
Active Dehumidification	Coil temperature is monitored and air flow is reduced for maximum latent moisture removal.	Variable Speed Only
SuperBoost	Allow the variable speed compressor to ramp up an extra 30% of cooling capacity if needed. This extra 'SuperBoost' will only be available for a 24 hr period and then the unit will revert to normal operation.	•
Smart Grid/Utility Input	Allows simple input to externally enable of occupied/unoccupied mode for basic utility time of use programs.	Dry Contact x1
Home Automation Alarm Input	Allows simple input to signal sump, security, or smoke/CO sensor alarms from other home automation or security systems. The two inputs can be field configured to a number of options and logic.	Dry Contact x2
HAN/Smart Grid Com (AWL and Portal) Kit	Allows direct communication of the Aurora to Smart Meters, Home Automation Network and Internet.	Optional AWL
IntelliZone2 Compatibility	IntelliZone2 communicates to the heat pump via the AXB board.	Optional IntelliZone2

Service Device	Description	Aurora Advanced VS
 Aurora Interface and Diagnostics (AID) Tool	Allows setup, monitoring and troubleshooting of any Aurora Control. NOTE: Although the ABC has basic compatibility with all Aurora, new product features may not be available on older AID Tools. To simplify the basic compatibility ensure the version of AID is at least the same or greater than the ABC software version.	For Service (Ver. 2.20 or greater)

Aurora Control System

Add On Control Feature Kits (field or factory Installed)	Description	Aurora Advanced VS
Geo Energy Monitoring Kit	Monitors real time power consumption of compressor, blower, aux heat and pump. Requires thermostat TPCM32U04A or TPCC32U02.	Standard
Refrigeration Monitoring Kit	Monitors real time pressures, temperatures, superheat, and subcooling.	Standard
Performance Monitoring Kit	Monitors air and water temperatures, and water flow rate and calculates heat of extraction/rejection.	Standard
Data Logging (AWL) Kit	Allows data logging of up to 12 months. Can also be temporarily installed.	Optional
HAN/Smart Grid Com (AWL and Portal) Kit	Allows direct communication of the Aurora to Smart Meters, HAN, and internet.	Optional

Add On Thermostats and Zoning	Description	Aurora Advanced VS
 <p>TPCM32U04A - MonoChrome Communicating Thermostat</p>	Elite Stat with full English fault codes and alerts, communicating thermostat; Required for viewing Energy Monitoring. Monochrome thermostat allows instantaneous energy measurement only. Compatible with AWL.	Optional
 <p>TPCC32U02 - Color Touchscreen Communicating Thermostat</p>	4.3 in. color touchscreen communicating thermostat with full English fault codes and alerts; Required for viewing Energy Monitoring. Color thermostat allows instantaneous and 13 month history. Compatible with AWL.	Optional
 <p>IntelliZone2' Zoning</p>	Includes color main thermostat and up to 6 zones (with variable speed), 4 zones (with dual capacity), and 2 zones (with single speed). There are 4 thermostat options (MasterStat, SensorStat, SensorStat Remote Kit, ZoneStat). Compatible with AWL. IntelliZone2 is not compatible with UPC controls.	Optional

NOTES: The IntelliZone2 or one of the communicating thermostats shown above must be used to control the variable speed heat pump.

Aurora Advanced VS Control Features

NOTE: Refer to the Aurora Advanced VS Control Application and Troubleshooting Guide and the Instruction Guide: Aurora Interface and Diagnostics (AID) Tool for additional information.

Control Features

Software ABC VS Version 4.0 Variable Capacity Compressors

- Random start at power up
- Anti-short cycle protection
- High and low pressure cutouts
- Loss of charge
- Water coil freeze detection
- Air coil freeze detection
- Over/under voltage protection
- Condensate overflow sensor
- Load shed
- Dehumidification (where applicable)
- Emergency shutdown
- Diagnostic LED
- Test mode push button switch
- Two auxiliary electric heat outputs
- Alarm output
- AWL compatible
- Accessory output with N.O. and N.C.
- Modbus communication

Variable Speed ECM Blower Motor

A variable speed ECM blower motor is driven directly using the onboard PWM output. Multiple blower speeds are available based upon requirements of the compressor and electric heat. The blower speeds can be changed either by the variable speed ECM manual configurations mode method or by using the Aurora AID Tool directly.

Advanced Hot Water Generator Control

An AID Tool selectable temperature limit and microprocessor control of the process is featured. This will maximize hot water generation and prevent undesirable energy use. An alert will occur when the hot water input temperature is at or above the set point (130°F default) for 30 continuous seconds. This alert will appear as an E15 on the AID Tool and the hot water pump de-energizes. Hot water pump operations resume on the next compressor cycle or after 15 minutes of continuous compressor operation during the current thermostat demand cycle. Since compressor hot gas temperature is dependent on loop temperature in cooling mode, loop temperatures may be too low to allow proper heating of water. The control will monitor water and refrigerant temperatures to determine if conditions are satisfactory for heating water.

Aurora Control System

VS Drive and Envelope Control

The VS drive operates the compressor between 20 and 100% capacity. The VS drive communicates any out of refrigerant envelope conditions to the Aurora and will attempt to adjust the compressor speed to keep within the envelope. These conditions are measured using the discharge and suction pressure transducers, discharge temperature, and current sensors of the drive.

IntelliZone2 Zoning Compatibility (Optional IntelliZone2 Communicating Zoning)

A dedicated input to connect and communicate with the IntelliZone2 (IZ2) zoning system is provided on P7 on the AXB control board. There is a dedicated communication port using a proprietary ModBus protocol. The AXB is standard on variable speed systems. Consult the IntelliZone2 literature for more information. Not compatible with UPC control opt.

Electronic Expansion Valve (EEV)

The electronic expansion valve is controlled by the AXB board and is set to maintain optimal superheat setting for maximum efficiency. All operation parameters are communicated to the VS drive and the Aurora system.

AWL - Aurora WebLink (Optional Accessory)

AWL is an add-on WiFi router that connects to the ABC and offers many features:

- Remote access to thermostat settings, schedules, etc. with your smartphone, tablet or laptop.
- Receive Lockout/Fault info via text or email.
- View heat pump energy usage from the internet for the day, week, month, year or real-time.
- Internet AID Tool capability allows remote troubleshooting for the technician.
- Remote AID Tool capability at the heat pump with smartphone, tablet or laptop for the technician.
- Allows data acquisition of the heat pump through the internet, see graphs of performance and chart historical data for the technician.
- Stores historical data on SD card.
- Not compatible with UPC control option

Variable Speed Pump

This input and output are provided to drive and monitor a variable speed pump. The VS pump output is a PWM signal to drive the variable speed pump. The minimum and maximum level are set using the AID Tool. 50% and 100% are the default settings respectively. The VS data input allows a separate PWM signal to return from the pump giving fault and performance information. Fault received from the variable speed pump will be displayed as E16.

Modulating Water Valve

This output is provided to drive a modulating water valve. Through advanced design the 0-10VDC valve can be driven directly from the VS Pump output. The minimum and maximum level are set in the same way as the VS pump using the AID Tool. 50% and 100% are the default settings respectively.

Loop Pump Linking

This input and output are provided so that two units can be linked together with a common flow center. When either unit has a call for loop outputs, both unit's loop pump relays and variable speed pumps are energized. The flow center then can simply be wired to either unit. The output from one unit should be routed to the input of the other. If daisy chained, up to 16 heat pumps can be linked together.

Advanced Communication Ports

AXB Communication ports P6 and P8 will provide future expansion via dedicated protocols. These are for future use.

Smart Grid/On Peak (SG) Input

The 'Smart Grid/On Peak' input was designed to allow utilities to utilize simple radio controlled switches to control the On Electric Peak behavior of the Geothermal Heat Pumps and provide demand reduction. With a closed contact signal, this input will limit the operation and thus the power consumption of the unit by disabling the compressor and electric heat as long as the signal is present. Code 7 will flash on the Green LED signifying the 'On Peak' mode. On Peak will also display on communicating thermostats.

Home Automation 1 and 2 Inputs

The Home Automation inputs are simple closed contact inputs that will trigger an AID Tool and thermostat alert for the homeowner. These would require optional sensors and or equipment for connection to the AXB board. With two inputs, two different sensors can be selected. The selected text will then be displayed on the AID Tool and communicating thermostats. These events will NOT alter functionality or operation of the heat pump/accessories and is for homeowner/service notification only.

Home Automation 1 - E23 HA1

With a closed dry contact signal, this input will cause an alarm and Alert Code 23 to indicate on the stat or flash on ABC. The AID Tool will allow configuration of this input between the following selections:

- *No Action*
- *Home Automation Fault* [no lockout info only] - Output from home automation system
- *Security Alarm* [no lockout info only] - Output from home security
- *Sump Alarm Fault* [no lockout info only] - Switch output from sump sensor
- *Smoke/CO Alarm Fault* [no lockout info only] - Switch output from Smoke/CO sensor
- *Dirty Filter Alarm* [no lockout info only] - Output from dirty filter sensor

Aurora Control System

Home Automation 2 – E24 HA2

With a closed dry contact signal, this input will cause an alarm and Alert Code 24 to indicate on the stat or flash on ABC. The AID Tool will allow configuration of this input between the following selections:

- *No Action*
- *Home Automation Fault* [no lockout info only] - Output from home automation system
- *Security Alarm* [no lockout info only] - Output from home security
- *Sump Alarm Fault* [no lockout info only] - Switch output from sump sensor
- *Smoke/CO Alarm Fault* [no lockout info only] - Switch output from Smoke/CO sensor
- *Dirty Filter Alarm* [no lockout info only] - Output from dirty filter sensor

Monitoring Sensor Kits

Energy Monitoring (Standard on all units)

The Energy Monitoring Kit includes two current transducers (blower and electric heat). The variable speed drive measures compressor drive power so that the complete power usage of the heat pump can be measured. The AID Tool provides configuration detail for the type of blower motor and a line voltage calibration procedure to improve the accuracy. This information can be displayed on the AID Tool or selected communicating thermostats. The TPCM32U04A will display instantaneous energy use while the color touchscreen TPCC32U02 will, in addition, display a 13 month history in graph form.

Refrigerant Monitoring

The Refrigerant Monitoring Kit includes two pressure transducers, and three temperature sensors, heating liquid line, suction temperature and existing cooling liquid line (FP1). These sensors allow the measurement of discharge and suction pressures, suction and liquid line temperatures as well as superheat and subcooling. This information will only be displayed on the AID Tool.

Performance Monitoring

The Performance Monitoring Kit includes three temperature sensors, entering and leaving water, leaving air temperature and a water flow rate sensor. With this kit heat of extraction and rejection will be calculated. This requires configuration using the AID Tool for selection of water or antifreeze.

Special Modes and Applications Communicating Digital Thermostats

The Aurora VS controls system also requires either the monochromatic or color touch screen graphic display thermostats for user interface. These displays not only feature easy to use graphical interface but display alerts and faults in plain English.

‘SuperBoost’ Cooling Mode

Occasionally there can be a requirement for a short term ‘boost’ of cooling capacity during a large party etc. The unit allows the user to select ‘SuperBoost’ mode on the thermostat which will allow the unit VS to ramp up an extra 30% of cooling capacity if needed. This extra ‘SuperBoost’ will only be available for a 24 hr period and then the unit will revert to normal operation. The short term boost does not affect ground loop sizing since it is limited in operation. Continuous use of SuperBoost will result in overheating of the ground loop.

Dehumidification – Active

Active dehumidification will only activate during cooling operation and is based upon the humidity setpoint of the thermostat being at least 5% below the actual relative humidity and being within the temperature parameters described here. The green status LED will flash code 2 when active. The unit can operate a maximum of 1.5°F below the cooling setpoint. The compressor will ramp up and airflow will begin at a low level. Airflow is then reduced periodically until air coil temperature setpoint is reached. If coil temperature continues to drop, the airflow is increased until air coil setpoint is maintained. After 20 minutes of operation in the Active Dehumidification mode, normal cooling operation will resume for 5 minutes. This cycle continues until the dehumidification setpoint is reached, room temperature is more than 1.5°F below cooling setpoint, or more than 1°F above cooling setpoint (normal cooling takes over). In IntelliZone2 systems, active dehumidification is only enabled when system is operating on compressor speeds 4 or lower. Once active dehumidification is activated the main zone and any other active cooling zone will remain open.

Field Hardware Selectable Options ABC Field Selectable Options via Button (SW1)

Test/Configuration Button (See SW1 Operation Table)

Test Mode

The control is placed in the test mode by holding the push button switch on the ABC SW1 for 2 - 5 seconds. In test mode most of the control timings will be shortened by a factor of sixteen (16). LED3 (green) will flash at 1 second on and 1 second off. Additionally, when entering test mode LED1 (red) will flash the last lockout one time. Test mode will automatically time out after 30 minutes. Test mode can be exited by pressing and holding the SW1 button for 2 to 5 seconds or by cycling the power. **NOTE:** Test mode will automatically be exited after 30 minutes.

Variable Speed ECM Configuration Mode

The control is placed in the variable speed ECM configuration mode by holding the push-button switch SW1 for 5 to 10 seconds, the high, low, and G variable speed ECM speeds can be selected by following the LED display lights. LED2 (yellow) will fast flash when entering the variable speed ECM configuration. When setting G speed LED3

Aurora Control System

(green) will be continuously lit, for low speed LED1 (red) will be continuously lit, and for high speed both LED3 (green) and LED1 (red) will be continuously lit. During the variable speed ECM configuration mode LED2 (yellow) will flash each of the 12 possible blower speeds 3 times. When the desired speed is flashed press SW1, LED2 will fast flash until SW1 is released. G speed has now been selected. Next select low speed, and high speed blower selections following the same process above. After third selection has been made, the control will exit the variable speed ECM configuration mode. Aux blower speed will remain at default or current setting and requires the AID Tool for adjustment.

Reset Configuration Mode

The control is placed in reset configuration mode by holding the push button switch SW1 on the ABC for 50 to 60 seconds. This will reset all configuration settings and the EEPROM back to the factory default settings. LED3 (green) will turn off when entering reset configuration mode. Once LED3 (green) turns off, release SW1 and the control will reset.

ABC DIP Switch (SW2)

- SW2-1** FP1 Selection - Low water coil temperature limit setting for freeze detection. On = 30°F; Off = 15°F.
- SW2-2** FP2 Selection - Low air coil temperature limit setting for freeze detection. On = 30°F; Off = Not Used
- SW2-3** RV - O/B - thermostat type. Heat pump thermostats with "O" output in cooling or "B" output in Heating can be selected. On = O; Off = B.
- SW2-4** Access Relay Operation (P2)

and 2-5

Access Relay Operation	SW2-4	SW2-5
Cycle with Blower	ON	ON
Cycle with Compressor	OFF	OFF
Water Valve Slow Opening	ON	OFF
Cycle with Comm. T-stat Hum Cmd	OFF	ON

- SW2-6** CC Operation - selection of single or dual capacity compressor. On = Single Stage; Off = Dual Capacity
NOTE: SW2-6 is not applicable to the unit
- SW2-7** Lockout and Alarm Outputs (P2) - selection of a continuous or pulsed output for both the LO and ALM Outputs. On = Continuous; Off = Pulsed
NOTE: SW2-7 is not applicable to the unit
- SW2-8** *Future Use*

Alarm Jumper Clip Selection

From the factory, ALM is connected to 24 VAC via JW2. By cutting JW2, ALM becomes a dry contact connected to ALG.

Variable Speed ECM Blower Speeds

The blower speeds can be changed either by using the variable speed ECM manual configurations mode method or by using the Aurora AID Tool directly (see Instruction Guide: Aurora Interface and Diagnostics (AID) Tool topic).

AXB DIP Switch (SW1)

DIP 1 - ID: This is the AXB ModBus ID and should always read On.

DIP 2 & 3 - Future Use

DIP 4 & 5 - Accessory Relay2: A second, DIP configurable, accessory relay is provided that can be cycled with the compressor 1 or 2, blower, or the Dehumidifier (DH) input. This is to complement the Accessory 1 Relay on the ABC board.

Position	DIP 4	DIP 5	Description
1	ON	ON	Cycles with blower or ECM (or G)
2	OFF	ON	Cycles with CC1 first stage of compressor or compressor spd 1-12
3	ON	OFF	Cycles with CC2 second stage of compressor or compressor spd 7-12
4	OFF	OFF	Cycles with DH input from ABC board

Field Selectable Options via Software

(Selectable via the Aurora AID Tool)

Many options are field selectable and configurable in Aurora software via the AID Tool. Consult the installation manual or Aurora documentation for further details.

Aurora Control System

Basic Aurora Safety Features

The following safety features are provided to protect the compressor, heat exchangers, wiring and other components from damage caused by operation outside of design conditions.

Fuse – a 3 amp automotive type plug-in fuse provides protection against short circuit or overload conditions.

Anti-Short Cycle Protection – 4 minute anti-short cycle protection for the compressor.

Random Start – 5 to 80 second random start upon power up.

Fault Retry – in the fault condition, the control will stage off the outputs and then “try again” to satisfy the thermostat VS call. Once the thermostat input calls are satisfied, the control will continue on as if no fault occurred. If 3 consecutive faults occur without satisfying the thermostat VS call, then the control will go to Lockout mode.

Lockout – when locked out, the blower will operate continuously in “G” blower speed setting. The Alarm output (ALM) and Lockout output (L) will be turned on. The fault type identification display LED1 (Red) shall flash the fault code. To reset lockout conditions with SW2-8 On, the demand call must be removed for at least 30 seconds. To reset lockout conditions with SW2-8 Off, the demand call must be removed for at least 30 seconds. Lockout may also be reset by turning power off for at least 30 seconds or by enabling the emergency shutdown input for at least 30 seconds.



CAUTION: Frequent cycling of power to the drive can damage the drive! Wait at least 5 minutes between cycles (connecting and disconnecting power to the drive).

Lockout With Emergency Heat – if the control is locked out in the heating mode, and a call for emergency heat is received, the control will operate in the emergency heat mode while the compressor is locked out. The first emergency heat output will be energized 10 seconds after the W input is received, and the blower will shift to high speed. If the control remains locked out, and the W input is present, additional stage of emergency heat will stage on after 2 minutes. When the W input is removed, all of the emergency heat outputs will turn off, and the variable speed ECM blower will shift to low speed.

High Pressure – fault is recognized when the Normally Closed High Pressure Switch, P4-9/10 opens, no matter how momentarily. The High Pressure Switch is electrically in series with the Compressor Contactor and serves as a hardwired limit switch if an overpressure condition should occur.

Low Pressure – fault is recognized when the Normally Closed Low Pressure Switch, P4-7/8 is continuously open for 30 seconds. Closure of the LPS any time during the 30 second recognition time restarts the 30 second continuous open requirement. A continuously open LPS shall not be recognized during the 2 minute startup bypass time.

Loss of Charge – fault is recognized when the Normally Closed Low Pressure Switch, P4-7/8 is open prior to the compressor starting.

Condensate Overflow – fault is recognized when the impedance between this line and 24 VAC common or chassis ground drops below 100K ohms for 30 seconds continuously.

Freeze Detection-Coax – set points shall be either 30°F or 15°F. When the thermistor temperature drops below the selected set point, the control shall begin counting down the 30 seconds delay. If the thermistor value rises above the selected set point, then the count should reset. The resistance value must remain below the selected set point for the entire length of the appropriate delay to be recognized as a fault. This fault will be ignored for the initial 2 minutes of the compressor run time.

Freeze Detection-Air Coil – Air Coil Freeze Detection will use the FP2 input to protect against ice formation on the air coil. The FP2 input will operate exactly like FP1 except that the set point is 30 degrees and is not field adjustable.

Over/Under Voltage Shutdown – An over/under voltage condition exists when the control voltage is outside the range of 18 VAC to 30 VAC. If the over/under voltage shutdown lasts for 15 minutes, the lockout and alarm relay will be energized. Over/under voltage shutdown is self-resetting in that if the voltage comes back within range of 18 VAC to 30 VAC for at least 0.5 seconds, then normal operation is restored.

Other Lockouts and Alarms

Several other lockouts and alarms are shown in the Status LED1 (LED1, Red) table with the associated codes visible on the thermostat, ABC Fault LED, and in text in the AID Tool.

Operation Description

Power Up – The unit will not operate until all the inputs and safety controls are checked for normal conditions. The unit has a 5 to 80 second random start delay at power up. Then the compressor has a 4 minute anti-short cycle delay after the random start delay.

Standby – In standby mode the compressor, pump, and blower motor are not active. The RV may be active. The blower and compressor will be off.

Heating Operation – The unit will operate based upon demand as calculated by the room setpoint algorithm. The resulting compressor speed (1-12) will also select an appropriate blower speed for the selected compressor speed. Aux Heat will not be available (on IntelliZone2 Aux Heat is available on compressor speeds 10-12) until after the 12th compressor speed has been operational and still is not satisfying the thermostat, then auxiliary electric heat will be activated.

Emergency Heat (W) – The blower will be started on G speed, 10 seconds later the first stage of electric heat will be turned on. 5 seconds after the first stage of electric heat is energized the blower will shift to Aux speed. If the emergency heat demand is not satisfied after 2 minutes the second electric heat stage will be energized.

Cooling Operation – The unit will operate based upon demand as calculated by the room setpoint algorithm. The resulting compressor speed, speeds 1-9, (speeds 10-12 are reserved for SuperBoost mode only) will also select an appropriate blower speed. The blower mode will also have the cooling airflow adjustment applied. In all cooling operations, the reversing valve directly tracks the O input. Thus, anytime the O input is present, the reversing valve will be energized.

Aurora Control System

Blower (G) - The blower will start immediately upon receiving a thermostat G command. If there are no other commands from the thermostat the variable speed ECM will run on low speed until the G command is removed. Regardless of blower input (G) from the thermostat, the blower will remain on low speed for 30 seconds at the end of each heating, cooling, and emergency heat cycle.

Emergency Shutdown - Four (4) seconds after a valid ES input, P2-7 is present, all control outputs will be turned off and remain off until the emergency shutdown input is no longer present. The first time that the compressor is started after the control exits the emergency shutdown mode, there will be an anti-short cycle delay followed by a random start delay. Input must be tied to common to activate.

Continuous Blower Operation - The blower output will be energized any time the control has a G input present, unless the control has an emergency shutdown input present. The blower output will be turned off when G input is removed.

Load Shed - The LS input disables all outputs with the exception of the blower output. When the LS input has been cleared, the anti-short cycle timer and random start timer will be initiated. Input must be tied to common to activate.

Aurora Interface and Diagnostics (AID) Tool

The Aurora Interface and Diagnostics (AID) Tool is a device that is a member of the Aurora network. The AID Tool is used to troubleshoot equipment which uses the Aurora control via Modbus RTU communication. The AID Tool provides diagnostics, fault management, variable speed ECM setup, and system configuration capabilities to the Aurora family of controls. An AID Tool is recommended, although not required, for variable speed ECM airflow settings. The AID Tool simply plugs into the exterior of the cabinet in the AID Tool port.



Aurora Control System

ABC Control Board Layout

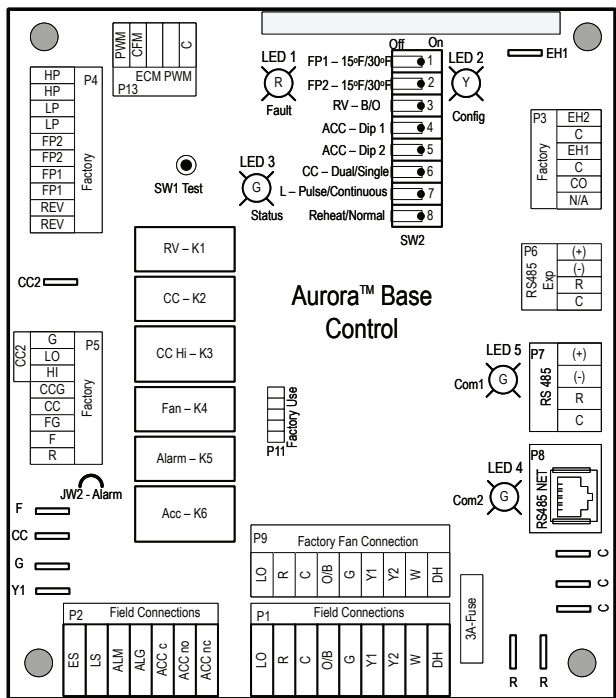

AXB Control Board Layout

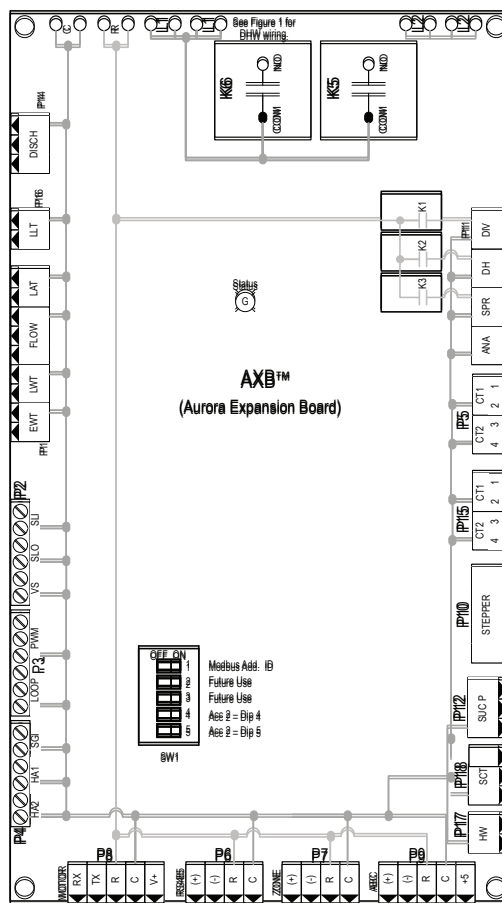

Variable Speed Drive

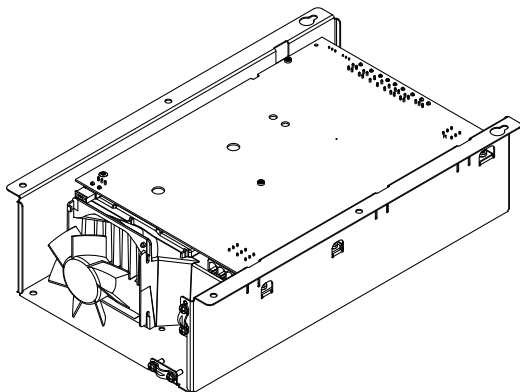

Aurora Control System



Aurora Contractor Connect and Symphony Contractor Connect

The Symphony Contractor Connect (SCC) brings ground source heat pump data and troubleshooting to your fingertips. Symphony Contractor Connect with the use of the Aurora Contractor Connect (ACC) replaces the current AID Tool. This app provides an enhanced and more efficient experience for the service technician in assessing system performance and component troubleshooting. REQUIRES dealer login credentials SCC is for dealer technicians ONLY and includes:

- AID Tool
- Troubleshooting videos and technical literature
- Easy AWL Setup to Home Router
- Perform routine installation chart reading/calculations
- Electronic capture of Start-Up Documentation
- Active Charge Assist/Charge Calculator for split system

Aurora Advanced VS Control LED Displays

These three LEDs display the status, configuration, and fault codes for the control. These can also be read in plain English via the Aurora AID Tool. See the LED tables for further explanation.

Status LED (LED3, Green)

Description of Operation	Fault LED, Green
Normal Mode	ON
Control is Non-functional	OFF
Test Mode	Slow Flash
Lockout Active	Fast Flash
Dehumidification Mode	Flash Code 2
Load Shed	Flash Code 5
Emergency Shutdown	Flash Code 6
On Peak Mode	Flash Code 7
Warning! VS Derated	Flash Code 8
Warning! VS SafeMode	Flash Code 9

Configuration LED (LED2, Yellow)

Description of Operation	Configuration LED, Yellow
No Software Overwritten	ECM Setting
DIP Switch Overwritten	Slow Flash
ECM Configuration Mode	Fast Flash
Reset Configuration Mode	OFF

Variable Speed 2.0 LED Status

LED Code	Full Description	Removal
ON	Normal operation of the heat pump	-
OFF	Microprocessor is not operational	Board replacement
Slow Flash	Speeds some timings for faster troubleshooting. Entered from pushed button on ABC	Auto after 20 min
Fast Flash	Lockout is active. Can be removed by hard or soft reset.	Hard or Soft Reset
Code 2	Unit has either Dehumidification Mode Call from dehumidistat (Active or Passive).	Remove Dehumid Call from Stat
Code 5	Active Load Shed (LS) input on ABC	Remove LS input
Code 6	Active Emergency Shutdown (ES) input on ABC	Remove ES input
Code 7	On Peak Mode is signalled from external source thru Smart Grid Input (dig1) or thru ext communication.	Remove Smart Grid Input or com
Code 8	Unit has encountered unacceptable condition and has moderated compressor speed to compensate.	Only automatic removal
Code 9	Unit has encountered unacceptable condition or lost EEV com and has adjusted operation to 2400 rpm and safe EEV %.	Only automatic removal

Aurora Control System

ASB Sensor Board

Refrigerant Leak Detection

The Aurora control system uses the ASB control board to monitor the refrigerant sensor and determine when a fault condition requiring mitigation has been recognized and is active.

The ASB control will provide the indicator for an active refrigerant leak condition requiring mitigation in addition to the currently measured refrigerant level in ppm for each sensor connected to the ASB.

Refrigerant Leak Mitigation

The refrigeration sensor will detect a leak if the LFL (Lower Flammability Limit) exceeds 13%. The ASB board will communicate the leak detection to the ABC control board. The ABC will deactivate the compressor, auxiliary heat and pump outputs. The system's blower will come on, and the system will continue to operate in this state until the ABC is no longer reporting a fault condition.

ASB Control Board

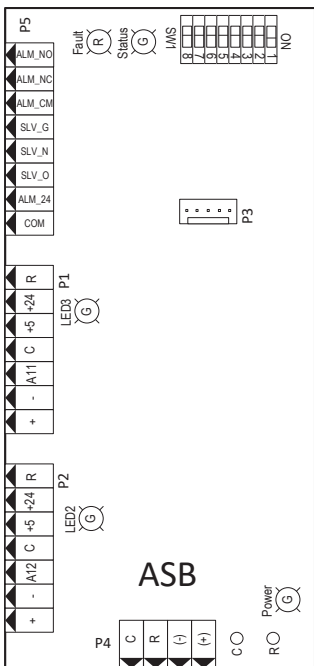

ASB Green Status LED	
OFF	Power Off
Slow Flash	Normal Operation
Fast Flash	ABC Loss Communication
ASB Red Fault LED	
OFF	Power Off
Slow Flash	Alarm
Fast Flash	Sensor Loss Communication

RDS Refrigeration Detection Sensor

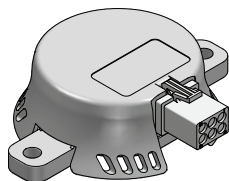

RDS Green Status LED	
Solid	Power Up / Self Test
Blinking	Normal Operation
RDS Red Fault LED	
Solid	Alarm State
Blinking	Sensor Fault

Aurora Control System

Variable Speed 2.0 LED Status

LED Flash Code	Lockout	Reset/Remove	Fault Condition Summary	ABC Action		AID Tool	I22 and Stat Display
				ABC Green Status LED	ABC Red Fault LED		
Off	-						
1	No	Auto	Tstat input error. Autoreset upon condition removal.	Normal	Code 1		
2	Yes	Hard or Soft	HP switch has tripped (>600 psi)	Lockout	Code 2	Lockout - E2 High Press	Lockout - E2 High Press
3	Yes	Hard or Soft	Low Pressure Switch has tripped (<40 psi for 30 continuous sec.)	Lockout	Code 3	Lockout - E3 Low Press	Lockout - E3 Low Press
4	Yes	Hard or Soft	Freeze protection sensor has tripped (<15 or 30 degF for 30 continuous sec.)	Lockout	Code 4	Lockout - E4 Freeze Detection FP2	Lockout - E4 Freeze Detection FP2
5	Yes	Hard or Soft	Freeze protection sensor has tripped (<15 or 30 degF for 30 continuous sec.)	Lockout	Code 5	Lockout - E5 Freeze Detection FP1	Lockout - E5 Freeze Detection FP1
7	Yes	Hard or Soft	Condensate switch has shown continuity for 30 continuous sec.	Lockout	Code 7	Lockout - E7 Condensate	Lockout - E7 Condensate
8	No**	Auto	Instantaneous Voltage is out of range. **Controls shut down until resolved.	Lockout	Code 8	Lockout - E8 Over/Under voltage	Lockout - E8 Over/Under voltage
11	Yes	Hard or Soft	If FPI or 2 Sensor Err	Lockout	Code 11	Lockout - E11 FPI/FP2 Sensor Error	Lockout - E11 FPI/FP2 Sensor Error
13	No	Auto	Any Other Sensor Err	Normal	Code 13	Alert - E13 Non-Critical AXB Sensor Error	Alert - E13 Non-Critical AXB Sensor Error
14	Yes	Hard or Soft	Sensor Err for EEV or HW	Lockout	Code 14	Lockout - E14 Critical AXB Sensor Error	Lockout - E14 Critical AXB Sensor Error
15	No	Auto	HW over limit or logic lockout. HW pump deactivated.	Normal	Code 15	Alert - E15 Hot Water Temp Limit	No Display
16	No	Auto	Alert is read from PWM feedback.	Normal	Code 16	Alert - E16 Var Spd Pump Err	Alert - E16 Var Spd Pump Err
17	No	Auto	I22 Com Fault. Autoreset upon condition removal.	Normal	Code 17	Warning - E17 I22 Comm Error	Warning - E17 I22 Comm Error
18	No	Auto	Any non-critical com error	Normal	Code 18	Alert - E18 Non-Critical Communication Error	Alert - E18 Non-Critical Communication Error
19	No	Auto	Any critical com error. Auto reset upon condition removal	Normal	Code 19	Alert - E19 Critical Communication Error	Alert - E19 Critical Communication Error
21	No	Auto	Loop pressure is below 3 psi for more than 3 minutes	Normal	Code 21	Alert - E51 Low Loop Pressure	No Display
23	No	Auto	Closed contact input is present on Dig 2 input - Text is configurable	Normal	Code 23	Alert - E23 Selected choice	Alert - E23 Selected choice
24	No	Auto	Closed contact input is present on Dig 3 input - Text is configurable	Normal	Code 24	Alert - E24 Selected Choice	Alert - E24 Selected Choice
41	No	Auto	Drive Temp has reached critical High Temp (>239°F/115°C)	Derated	Code 41	Warning! Derated - E41 DriveTemp	Warning! Derated - E41 DriveTemp
42	No	Auto	Discharge temperature has reached critical high temp (> 280°F/138°C)	Derated	Code 42	Warning! Derated - E42 HiDisTemp	Warning! Derated - E42 HiDisTemp
43	No	Auto	Suction Pressure is critically low (< 28 psig)	Derated	Code 43	Warning! Derated - E43 LoSucPres	Warning! Derated - E43 LoSucPres
44	No	Auto	Condensing pressure is critically high (> 654 psig)	Derated	Code 44	Warning! Derated - E44 LoConPress	Warning! Derated - E44 LoConPress
45	No	Auto	Condensing pressure is critically high (> 654 psig)	Derated	Code 45	Warning! Derated - E45 HiConPress	Warning! Derated - E45 HiConPress
46	No	Auto	Supply Voltage is <208V or Max Pwr is reached due to high pressure	Derated	Code 46	Warning! Derated - E46 OutPwrLmt	Warning! Derated - E46 OutPwrLmt
47	No	Auto	Com with EEV is interrupted EEV has gone independent mode	SafeMode	Code 47	Warning! SafeMode - E47 EEVIndCom	Warning! SafeMode - E47 EEVIndCom
48	No	Auto	Com with EEV is interrupted EEV has gone independent mode	SafeMode	Code 48	Warning! SafeMode - E48EEVOutCom	Warning! SafeMode - E48EEVOutCom
49	No	Auto	Ambient Temperature (T _{amb}) is <-76 or > 212 F and out of range or invalid	SafeMode	Code 49	Warning! SafeMode - E49	Warning! SafeMode - E49
51	Yes	Hard or Soft	Discharge Sensor (Sd) is > 280 F or invalid (-76 to 392 F)	Lockout	Code 51	Lockout! - E51 DisTempSnr	Lockout! - E51 DisTempSnr
52	Yes	Hard or Soft	Suction Pressure (P _s) is invalid (0 to 232 psi)	Lockout	Code 52	Lockout! - E52 SucPrsSnr	Lockout! - E52 SucPrsSnr
53	10x then Yes	Hard or Soft	Low condensing pressure (P _c) or invalid (0 to 870 psi) Retry 10x.	Norm then Lockout	Code 53	Lockout! - E53 ConPrsSnr	Lockout! - E53 ConPrsSnr
54	Yes	Hard or Soft	Supply Voltage is <180V (190V to reset) or powered off/on too quickly (<30 sec.)	Lockout	Code 54	Lockout! - E54 LowSupVolt	Lockout! - E54 LowSupVolt
55	10x then Yes	Hard or Soft	Com Operating out of envelope (P _c) more than 90 sec. Retry 10x.	Norm then Lockout	Code 55	Lockout! - E55 OutEnvelop	No Display
56	Yes	Hard or Soft	Over current tripped by phase loss, earth fault, short circuit or major drive fault.	Lockout	Code 56	Lockout! - E56 OverCurrnt	Lockout! - E56 OverCurrnt
57	Yes	Hard or Soft	DC Link Voltage to compressor is >450Vdc or at minimum voltage (<185Vdc).	Lockout	Code 57	Lockout! - E57 Over/Under Volt	Lockout! - E57 Over/Under Volt
58	Yes	Hard or Soft	Drive Temp has reached critical High Temp >239 F	Lockout	Code 58	Lockout! - E58HiDrivTemp	Lockout! - E58HiDrivTemp
59	Yes	Hard or Soft	The MOC has encountered an internal fault or an internal error. Probably fatal.	Lockout	Code 59	Lockout! - E59 DrvIntErr	Lockout! - E59 DrvIntErr
61	Yes	Hard or Soft	More than one SafeMode condition is present: requiring lockout.	Lockout	Code 61	Lockout! - E61 MultSafeMd	Lockout! - E61 MultSafeMd
71	Yes	Hard or Soft	High superheat and high EEV opening % for a long time will trigger a loss of charge fault	Lockout	Code 71	Lockout! - E71 LossCharge	Lockout! - E71 LossCharge
72	No	Auto	Suction Temperature Sensor is invalid (-76 to 392 F)	SafeMode	Code 72	Warning! SafeMode - E72 SucTempSnr	Warning! SafeMode - E72 SucTempSnr
73	No	Auto	Leaving Air Temperature Sensor is invalid (-76 to 392 F)	Normal	Code 73	Alert - E73 LAT Sensor	No Display
74	No	Auto	Suction pressure has exceeded that maximum operating level for 90 sec.	SafeMode	Code 74	Warning! SafeMode - E74 MaxOpPress	Warning! SafeMode - E74 MaxOpPress

Refrigerant Circuit Guideline

Symptom	Head Pressure	Suction Pressure	Compressor Amp Draw	Superheat	Subcooling	Air Temp. Differential	Water Temp. Differential
Under Charged System (Possible Leak)	Low	Low	Low	High	Low	Low	Low
Over Charged System	High	High	High	Normal	High	Normal/Low	Normal
Low Air Flow Heating	High	High	High	High/Normal	Low	High	Low
Low Air Flow Cooling	Low	Low	Low	Low/Normal	High	High	Low
Low Water Flow Heating	Low/Normal	Low/Normal	Low	Low	High	Low	High
Low Water Flow Cooling	High	High	High	High	Low	Low	High
High Air Flow Heating	Low	Low	Low	Low	High	Low	Low
High Air Flow Cooling	Low	High	Normal	High	Low	Low	Normal
High Water Flow Heating	Normal	Low	Normal	High	Normal	Normal	Low
High Water Flow Cooling	Low	Low	Low	Low	High	Normal	Low
Low Indoor Air Temperature Heating	Low	Low	Low	Normal	High	Normal	Normal/High
Low Indoor Air Temperature Cooling	Low	Low	Low	Normal/Low	High	Low	Low
High Indoor Air Temperature Heating	High	High	High	Normal/High	Normal/Low	Low	Normal
High Indoor Air Temperature Cooling	High	High	High	High	Low	Low	High
Restricted EEV (Check Service Advisory)	High	Low	Normal/Low	High	High	Low	Low
Insufficient Compressor (Possible Bad Valves)	Low	High	Low	High	Normal/High	Low	Low
Scaled Coaxial Heat Exchanger Heating	Low	Low	Low	Normal/Low	High	Low	Low
Scaled Coaxial Heat Exchanger Cooling	High	High	High	Normal/Low	Low	Low	Low
Restricted Filter Drier	Check temperature difference (delta T) across filter drier.						

6/1/12

Electrical Information

General

Be sure the available power is the same voltage and phase as that shown on the unit serial plate. Line and low voltage wiring must be done in accordance with local codes or the National Electric Code, whichever is applicable. The compressor has no internal overload. The circuit breaker in the control box is the overload protection for the drive and the compressor. Bypassing the circuit breaker could result in damage to the compressor and voiding the warranty.

Unit Power Connection

Connect the incoming line voltage wires to L1 and L2 of the contactor as shown in Figure 13c for single-phase unit. Consult the Unit Electrical Data in this manual for correct fuse sizes.

Open lower front access panel. Remove ground fastener from bottom of control box (Figure 13b). Swing open control box (Figure 13a). Insert power wires through knockouts on lower left side of cabinet. Route wires through left side of control box and connect to contactor and ground (Figure 13c). Close control box and replace grounding fastener before unit startup.



CAUTION: Frequent cycling of power to the drive can damage the drive! Wait at least 5 minutes between cycles (connecting and disconnecting power to the drive).

Accessory Relay

A set of “dry” contacts has been provided to control accessory devices, such as water solenoid valves on open loop installations, electronic air cleaners, humidifiers, etc. This relay contact should be used only with 24 volt signals and not line voltage power. The relay has both normally open and normally closed contacts and can operate with either the blower or the compressor. Use DIP switch SW2-4 and 5 to cycle the relay with blower, compressor, or control a slow opening water valve. The relay contacts are available on terminals #1 and #3 for normally closed, and on terminals #2 and #3 for normally open on P2.

A second configurable accessory relay is provided on the AXB board. When powering high VA draw components such as electronic air cleaners or VM type open loop water valves, R should be taken ‘pre-fuse’ from the ‘R’ quick connect on the ABC board and not the ‘post-fuse’ ‘R’ terminal on the thermostat connection. If not, blown ABC fuses might result.

208 Volt Operation

All 208/230 units are factory wired for 230 volt operation. For 208 volt operation, the red and blue transformer wires must be switched on terminal strip PS.

Figure 13a:
Wire access (control box open)

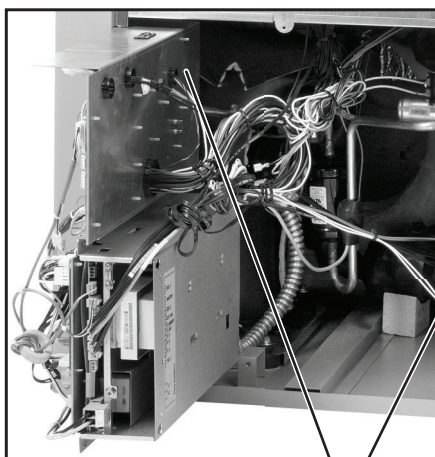

Wire Insert Location

Figure 13b:
Wire access (control box closed)

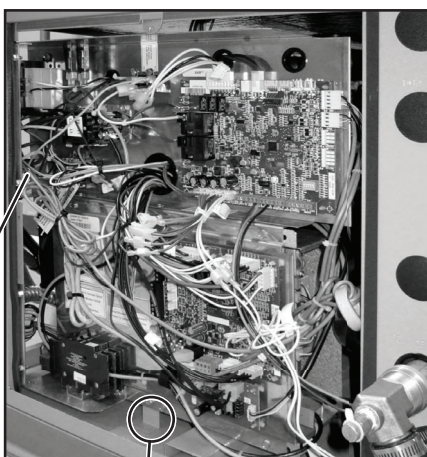

Ground Fastener must be installed for proper unit ground

Figure 13c:
Line Voltage 208-230/60/1 control box

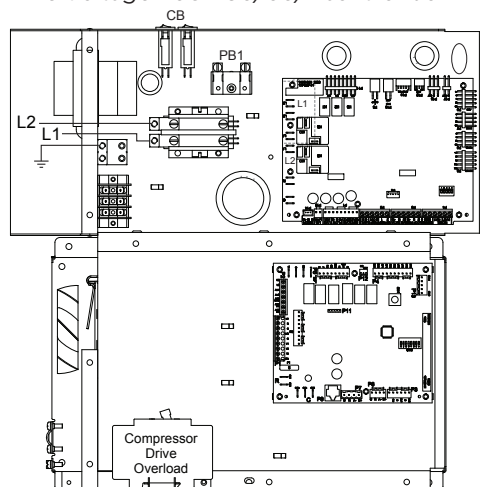

Electronic Thermostat Installation

Position the thermostat subbase against the wall so that it is level and the thermostat wires protrude through the middle of the subbase. Mark the position of the subbase mounting holes and drill holes with a 3/16-inch bit. Install supplied anchors and secure base to the wall. Thermostat wire must be 4 or 5 conductor for communicating thermostats, 20-AWG (minimum) wire. Shielded communication cable is recommended. Strip the wires back 1/4-inch (longer strip lengths may cause shorts) and insert the thermostat wires into the P7 connector as shown. Tighten the screws to ensure secure connections. The thermostat may have either screw or spring clip connectors, requiring the same wiring. **See instructions enclosed in the thermostat for detailed installation and operation information.**

Figure 15: Thermostat Wiring (Communicating Style Signals)

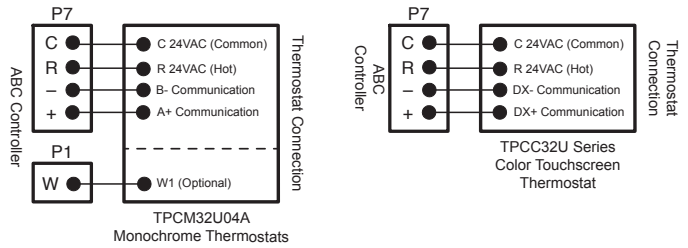

NOTE: If using the IntelliZone2 zoning system, then disregard the diagrams above. The IntelliZone2 system will connect directly to the AXB control board instead. See the IntelliZone2 installation manual for more details.

Electrical Information

Fixed Speed Flow Center

The pump(s) will be connected to the terminals on PB1 in the unit electrical box as shown in Figure 3a. The pumps will automatically be cycled as required by the unit or by a signal from another unit sharing the flow center (See Figures 5 and 6). Pumps are protected by circuit breakers (CB) shown in Figure 3a.

Figure 3a: Variable Speed Unit Wiring for Loop Pumps

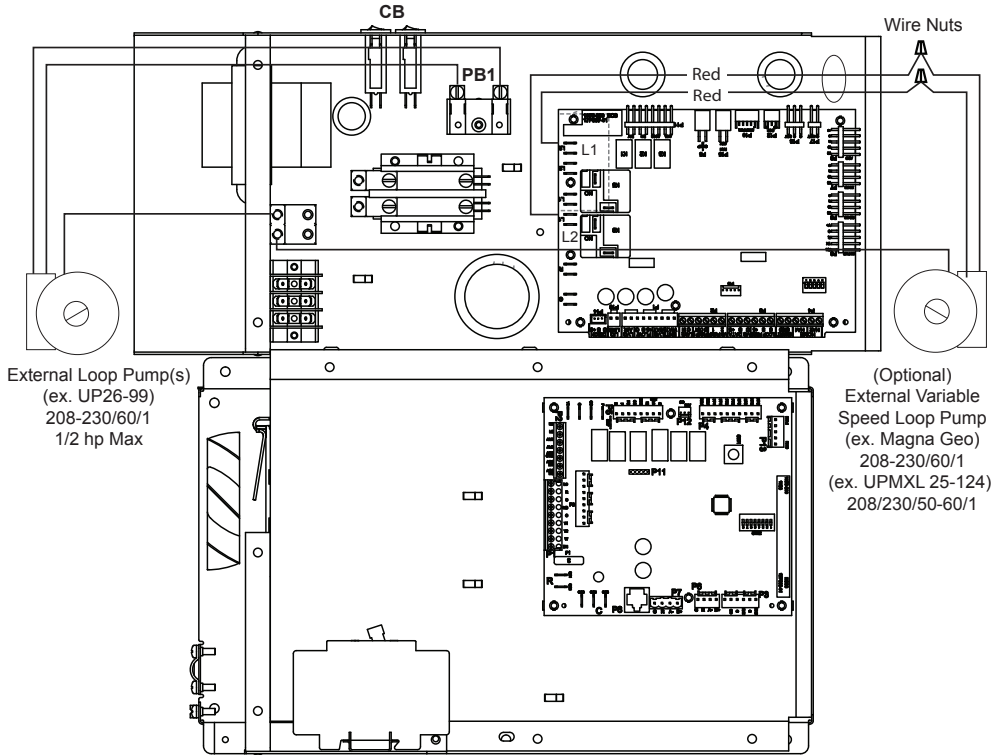

NOTES: For closed loop systems with antifreeze protection, set SW2 DIP Switch #1 to the "Loop" position on units with the Aurora control and SW2-2 should be set to "Loop" on the Premier control.

Figure 3c: FLXL2D-W and FCL Flow Center Wiring (Not Referenced)

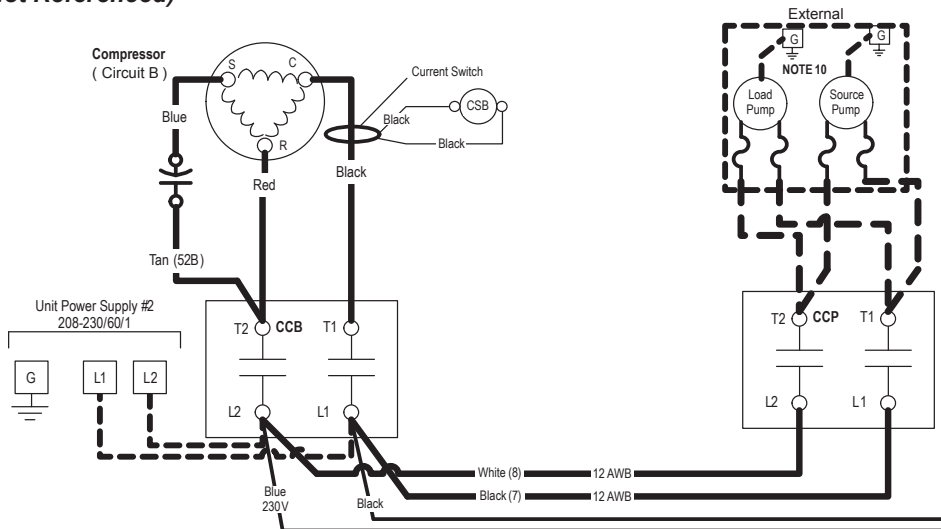

NOTES: FLXL2D-W and FCL Flow Centers must be wired to a separate contactor (20 amp minimum). The HydroZone Accessory Control Box works best for this application.

Electrical Information - Flow Centers

Variable Speed Flow Center cont.

Two Pump Variable Speed Flow Center

If a variable speed two pump flow center is used, the flow center will come with four red and two green wires for the high voltage wiring. The second set of (2) red and (1) green wires is provided for installation flexibility. The variable speed pump **MUST** be powered at all times and therefore **MUST** be wired to the “L” side of electrical system or damage to the pump will occur (pump cannot be powered from “T” side of compressor contactor). The UPMXL 25-124 pump has screw terminals for the high voltage connection. Connect the red HIGH VOLTAGE wires to L1 and L2 on the AXB, connect the green GROUND wire to the ground lug, as shown in figure 4d. Follow all electrical and local codes for wiring.

The variable speed UPMXL 25-124 pump also requires a low voltage signal to operate properly, if the low voltage signal isn't present the pump will run at 100%. Route the low voltage harness connected to the right hand pump to the AXB screw terminals on P2 and P3 connectors. Route the low voltage harness connected to the left hand pump to the AXB screw terminals on P2 and P3 connector per figure 4c. The black wire on the left hand pump will have a label on it that reads **“DO NOT CONNECT THIS WIRE. ONLY ONE VS PUMP FEEDBACK SIGNAL CAN BE CONNECTED TO AXB BOARD”**.

Both the low and high voltage harnesses are labeled. The pump will be automatically cycled as required either by the unit or by a signal from another unit sharing the same flow center. Pumps are protected by circuit breakers as shown on the unit schematic.

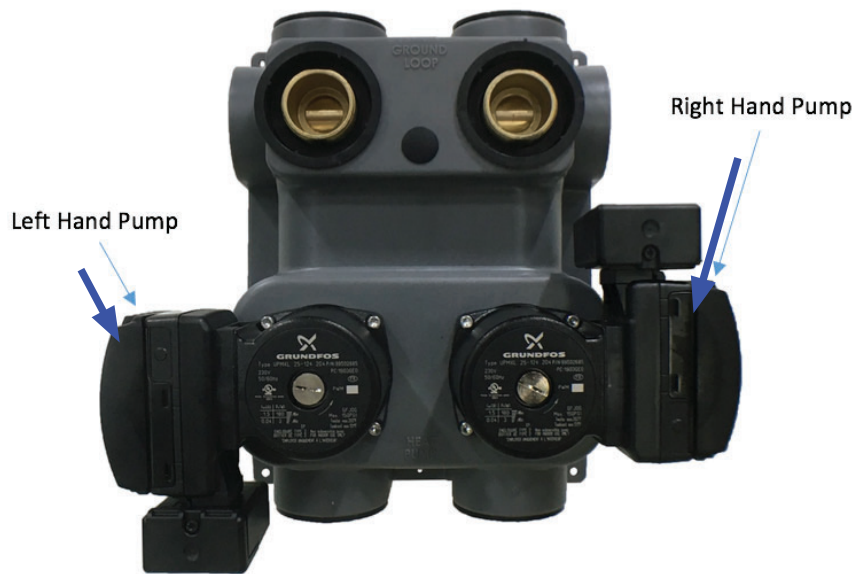

NOTE: Both pumps will speed up and slow down together.

Electrical Information - Flow Centers (cont.)

Fixed Speed Flow Center

The pump(s) will be connected to the terminals on PB1 in the unit electrical box as shown in Figure 3a. The pumps will automatically be cycled as required by the unit or by a signal from another unit sharing the flow center (See Figures 5 and 6). Pumps are protected by circuit breakers (CB) shown in Figure 3a.

Variable Speed Flow Center

Single Pump Variable Speed Flow Center

If a variable speed single pump flow center is used, the flow center will come with two red and one green wires for the high voltage wiring. The variable speed pump **MUST** be powered at all times and therefore **MUST** be wired to the "L" side of electrical system or damage to the pump will occur (pump cannot be powered from "T" side of compressor contactor). Connect the red HIGH VOLTAGE wires to L1 and L2 on the AXB, connect the green GROUND wire to the ground lug, as shown in figure 4a. Follow all electrical and local codes for wiring.

The variable speed UPMXL 25-124 pump also requires a low voltage signal to operate properly, if the low voltage signal isn't present the pump will run at 100%. Route the low voltage harness connected to the pump to the AXB screw terminals on P2 and P3 connectors per diagram 4b.

Both the low and high voltage harnesses are labeled. The pump will be automatically cycled as required either by the unit or by a signal from another unit sharing the same flow center. Pumps are protected by circuit breakers as shown on the unit schematic.

Figure 4a: Single VS Pump High Voltage Wiring

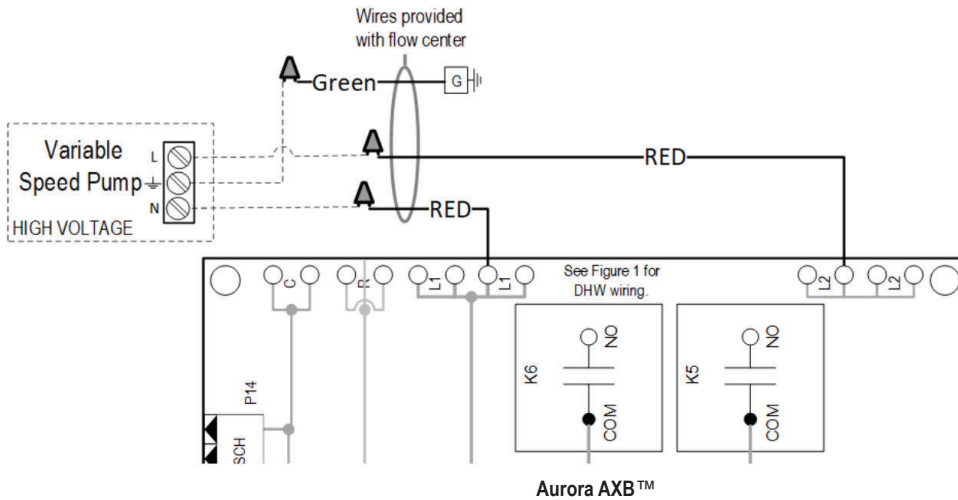
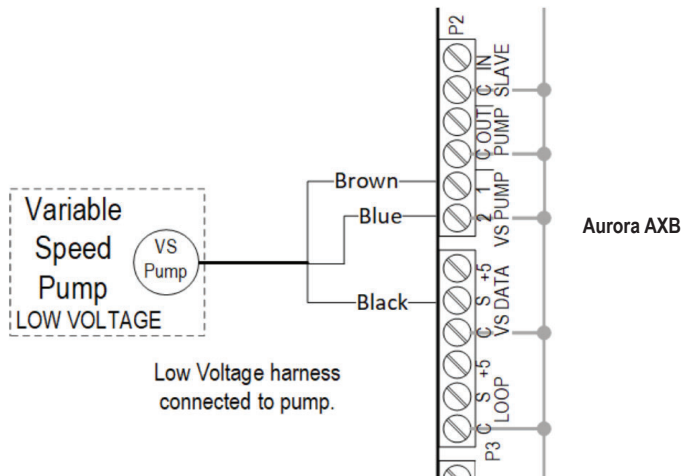

Figure 4b: Single VS Pump Low Voltage Wiring



Note: Aurora AXB must be used to control the UPMXL 25-124 pump.

Electrical Information - Flow Centers (cont.)

Two Pump Variable Speed Flow Center cont.

The use of the black wire on the left hand pump (Bottom on NP/NPD with 2 VS pumps in same circuit) is ONLY to be connected for troubleshooting of the pumps. The left hand pump (Bottom on NP/NPD with 2 VS pumps in same circuit) will have a closed end splice connector crimped to the black wire. Cut the closed end splice connector off and strip the wire. During troubleshooting remove the black wire from the right hand pump (Top on NP/NPD with 2 VS pumps in same circuit) from the AXB P3 VS DATA S screw terminal and connect the black wire from the left hand pump (Bottom on NP/NPD with 2 VS pumps in same circuit) to the same location. After the troubleshooting is complete remove the black wire from the left hand pump and connect the black wire from the right hand pump.

Place electrical tape or wire nut on the left hand pump (Bottom on NP/NPD with 2 VS pumps in same circuit) black wire. The two pump variable speed flow center cannot have each UPMXL 25-124 pump wired to two separate heat pumps otherwise damage to the pumps will occur (unless it's an NPD Series flow center).

Figure 4c: Two VS Pump Low Voltage Wiring

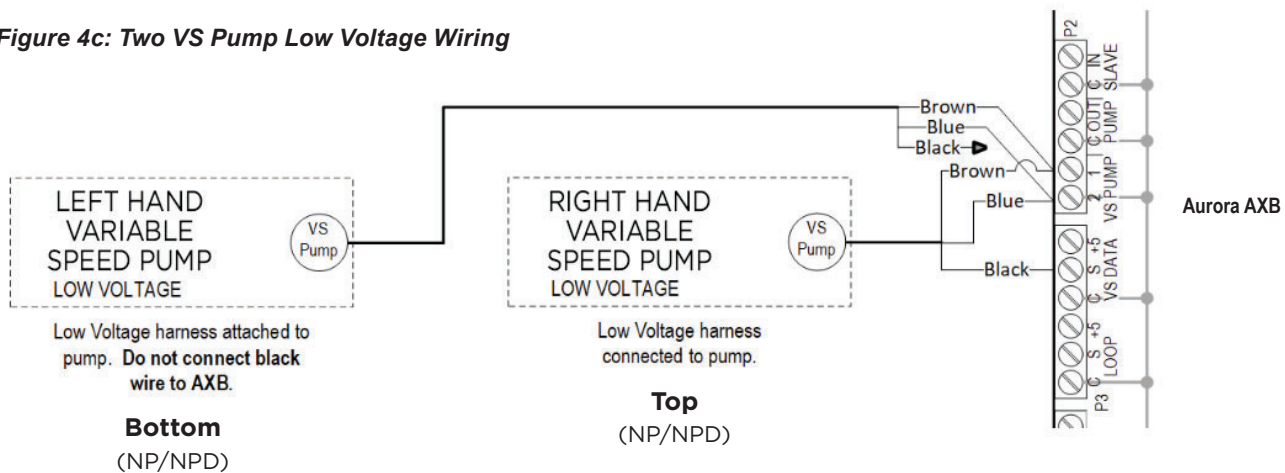
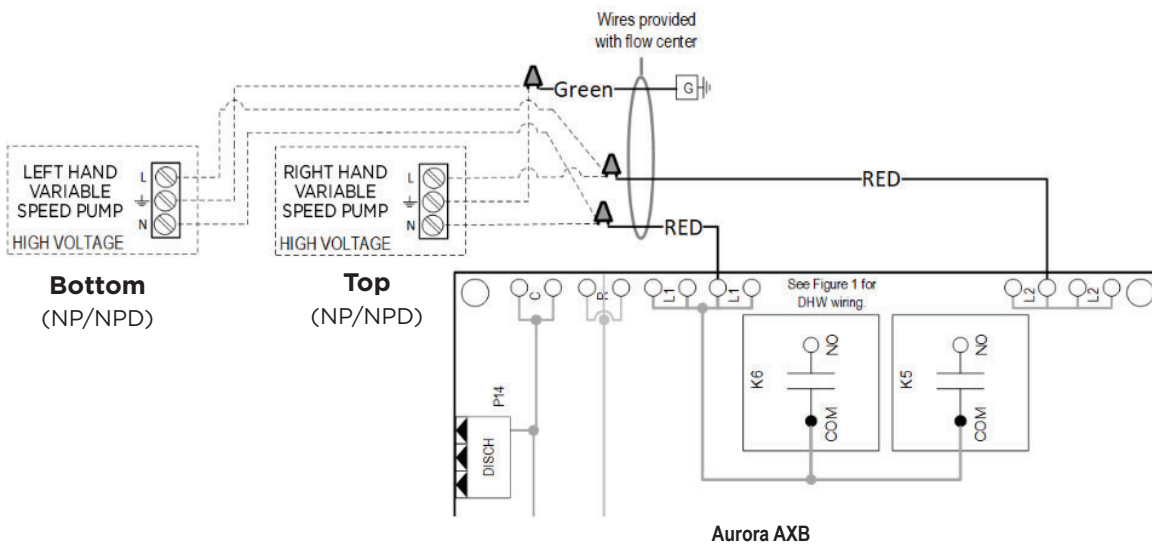

Figure 4d: Two VS Pump High Voltage Wiring



Closed Loop Ground Source Systems

NOTE: For closed loop systems with antifreeze protection, set SW2-1 to the “LOOP” (15°F) position. (Refer to the DIP Switch Settings table in the Aurora Control section.)

Once piping is completed between the unit, pumps and the ground loop, final purging and charging of the loop is required. A flush cart (or a 1.5 HP pump minimum) is needed to achieve adequate flow velocity in the loop to purge air and dirt particles from the loop itself. A filter **MUST** be used when flushing a loop. The standard 100 micron filter bag (LFC-F100M) is acceptable for capturing relatively large debris such as pipe shavings, gravel, and medium sand particles. In certain installation locations other smaller materials such as fine sand, silt, and clay can be less than 75 microns. For these smaller particles the use of the 1 micron filter bag is required (LFC-F1M). It is also recommended to run the flush cart with the 1 micron filter bag for at least 30 minutes. Antifreeze solution is used in most areas to prevent freezing. Flush the system adequately to remove as much air as possible then pressurize the loop to a static pressure of 40-50 psi (summer) or 50-75 psi (winter). This is normally adequate for good system operation. Loop static pressure will fluctuate with the seasons. Pressures will be higher in the winter months than during the cooling season. This fluctuation is normal and should be considered when initially charging the system.

After pressurization, be sure to turn the venting (burping) screw in the center of the pump two (2) turns open (water will drip out), wait until all air is purged from the pump, then tighten the plug. Ensure that the loop pumps provide adequate flow through the unit(s) by checking the pressure drop across the heat exchanger and comparing it to the unit capacity data in this catalog. 2.5 to 3 gpm of flow per ton of cooling capacity is recommended in earth loop applications.

Figure 7: Closed Loop Ground Source Application

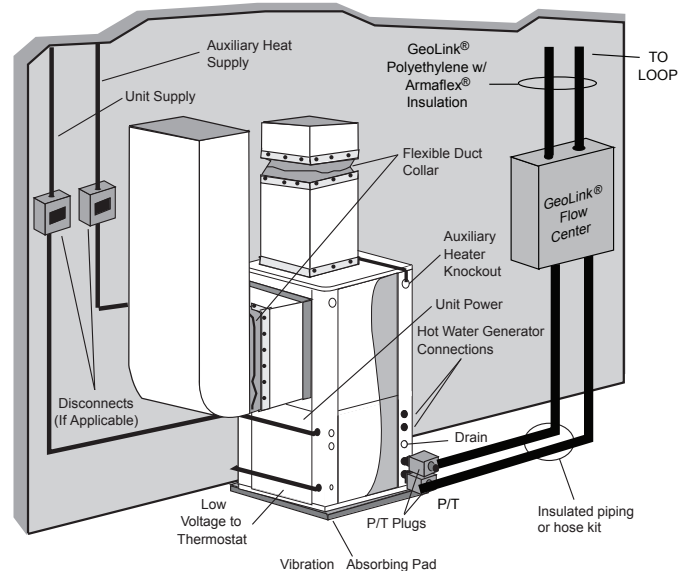

NOTE: Additional information can be found in Flow Center installation manual and Flush Cart manual.

Closed Loop Ground Source Systems cont.

Multiple Units on One Flow Center

When two units are connected to one loop pumping system, pump control is automatically achieved by connecting the SL terminals on connector P2 in both units with 2-wire thermostat wire. These terminals are polarity dependant (see Figure 8). The loop pump(s) may be powered from either unit, whichever is more convenient. If either unit calls, the loop pump(s) will automatically start. The use of two units on one flow center is generally limited to a total of 20 gpm capacity. It is recommended that water solenoid valves be installed on heat pumps that share a flow center. This is to allow water flow through only the heat pump that has a demand. Circulating fluid through a heat exchanger of a system that is not operating could be detrimental to the long term reliability of the compressor.

Variable Speed Pump Setup

When using a variable speed pump flow center (FCV type) the use of an AID Tool will be necessary to adjust minimum and maximum flow rates. The factory default is: minimum=50% and maximum=100% speed levels. See the unit Variable Speed Pump Setup and Modulating Water Valve Setup instructions within the Unit Startup section which is located in the back of this manual. Always ensure that there is adequate flow for the heat pump. See Recommended Minimum/Maximum Flow Rates table.

NOTE: When sharing a flow center, the variable speed heat pump should be the primary unit. When two variable speed heat pumps share a flow center, the larger capacity heat pump should be the primary unit.

Recommended Minimum/Maximum Flow Rates

Size	Closed Loop (minimum)	Closed Loop (maximum)	Open Loop (minimum)	Open Loop (maximum)
	Flow Rate GPM	Flow Rate GPM	Flow Rate GPM	Flow Rate GPM
024-036	5.0	12.0	5.0	8.0
48	5.0	15.0	5.0	10.0
60	5.0	18.0	5.0	12.0

5/13/24

Figure 8: Primary/Secondary Hook-up

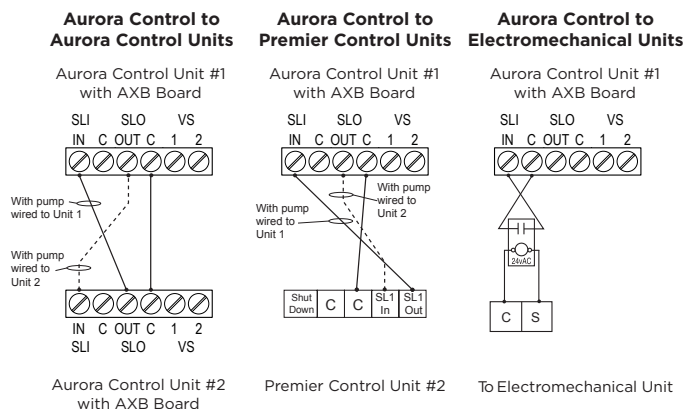

Open Loop Ground Water Systems

Typical open loop piping is shown below. Always maintain water pressure in the heat exchanger by placing water control valves at the outlet of the unit to prevent mineral precipitation. Use a closed, bladder-type expansion tank to minimize mineral formation due to air exposure. Ensure proper water flow through the unit by checking pressure drop across the heat exchanger and comparing it to the figures in unit capacity data tables in the specification catalog. 1.5-2 gpm of flow per ton of cooling capacity is recommended in open loop applications.

Discharge water from the unit is not contaminated in any manner and can be disposed of in various ways, depending on local codes, i.e. recharge well, storm sewer, drain field, adjacent stream or pond, etc. Most local codes forbid the use of sanitary sewer for disposal. Consult your local building and zoning departments to assure compliance in your area. On VS systems, a modulating valve, as shown in figure 9a is the best choice to limit water consumption. The WWKVS well water kit with modulating valve is the recommended setup for open loop applications with variable speed products.

NOTE: For open loop/groundwater systems or systems that do not contain an antifreeze solution, set SW2-Switch #1 to the "WELL" (30°F) position. (Refer to the DIP Switch Settings in the Aurora Control section.) Slow opening/closing solenoid valves (type V) or modulating valves are recommended to eliminate water hammer.

Modulating Water Valve Setup

When using a modulating water valve kit (4MWVK or 5MWVK) the use of an AID Tool will be necessary to adjust minimum and maximum flow rates. The factory default is: minimum=50% and maximum=100% flow levels. It is recommended to start with a minimum setting of 65% and adjust from there if necessary. See the Variable Speed Pump Setup and Modulating Water Valve Setup instructions within the Unit Startup section which is located in the back of this manual. See Recommended Minimum and Maximum Flow Rates table. Always ensure that there is adequate flow for the heat pump. A modulating water valve is preferred on variable speed system to conserve water.

Figure 10: Open System - Groundwater Application

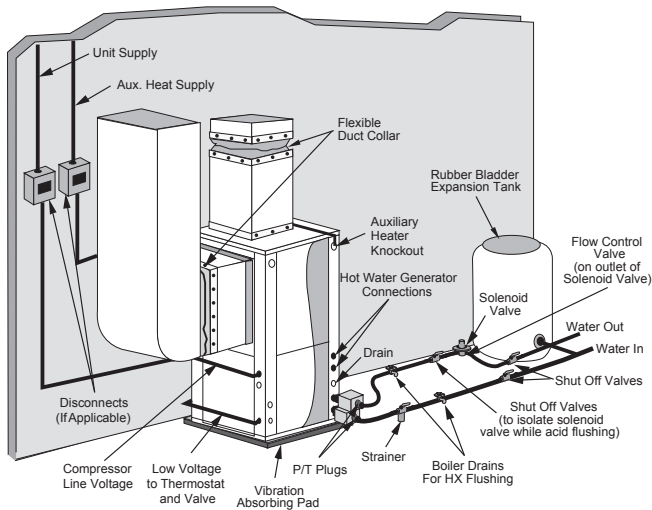

Figure 9a: Modulating Water Valve Connection Option

Typical 0-10VDC modulating water valve.

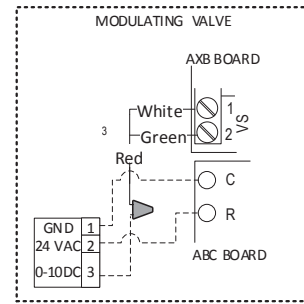

Figure 9b: Open Loop Solenoid Valve Connection Option

Typical slow operating external 24V water solenoid valve (type V) wiring.

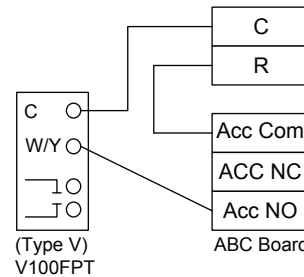
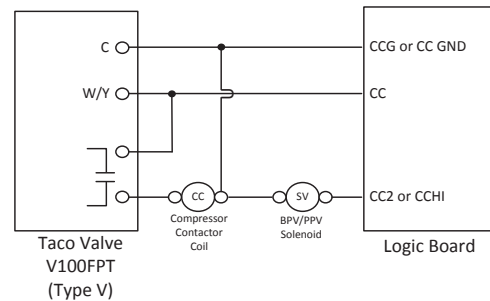

Figure 9c: Wiring diagram for dual water valve installations, one type V slow operating solenoid and one BPV100/PPV100 quick operating solenoid.



Note: SW2-4 should be 'ON' and SW2-5 should be 'OFF'.

Figure 9d: Open Loop Solenoid Valve Connection Option

Typical quick operating external 24V water solenoid valve (type PPV100 or BPV100) wiring.

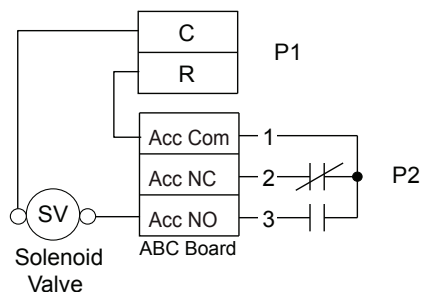

NOTE: SW2-4 and SW2-5 should be "OFF" to cycle with the compressor.

Compressor & Thermistor Resistance

Model	Compressor Model No.	Winding Resistance at 70 °F
		208-230/60/1
024-036	VZH028CWDMB	0.185 ± 7%
048	VZH035CWDMB	0.185 ± 7%
060	VZH044CWDMB	0.185 ± 7%

5/13/24

VRJ scroll compressors are equipped with an IPM (permanent magnet motor). Winding resistance is the resistance between indicated terminal pins at 77°F (Resistance value ± 7%). Winding resistance is generally low and it requires adapted tools for precise measurement. Use a digital ohm-meter capable of connecting a 4 wire probe. Use the 4 Wire Kelvin method and measure resistances under stabilized ambient temperature. Winding resistance varies strongly with winding temperature; If the compressor is stabilized at a different value than 77°F, the measured resistance must be corrected with the following formula:

$$R_{tamb} = R_{77°F} \frac{a + t_{amb}}{a + t_{77°F}}$$

$t_{77°F}$: reference temperature = 77°F

t_{amb} : temperature during measurement (°F)

$R_{77°F}$: winding resistance at 77°F

R_{tamb} : winding resistance at t_{amb}

a : Coefficient a = 390

Thermistor Resistance (10k Ohm) for FP1, FP2, HWL, suction line, LAT, LWT and LLT (EWT with Performance Option)		Thermistor Resistance (1k Ohm) for compressor discharge line, compressor ambient and EWT	
Thermistor Temperature (°F)	Thermistor Resistance (Ohms)	Thermistor Temperature (°F)	Thermistor Resistance (Ohms)
5	75757-70117	20	974.4-973.4
14	57392-53234	25	985.4-984.4
23	43865-40771	30	996.1-995.1
32	33809-31487	35	1007.0-1006.0
41	26269-24513	40	1017.8-1016.8
50	20570-19230	45	1028.6-1027.6
59	16226-15196	50	1039.5-1038.5
68	12889-12093	55	1050.2-1049.2
77	10310-9688	60	1061.2-1060.2
86	8300-7812	65	1072.9-1071.9
95	6723-6337	70	1082.7-1081.7
104	5480-5172	75	1093.4-1092.4
113	4490-4246	80	1103.0-1102.0
122	3700-3504	85	1115.5-1114.5
131	3067-2907	90	1126.2-1125.2
140	2554-2424	95	1136.6-1135.6
149	2149-2019	100	1147.2-1146.2
		105	1158.1-1157.1
		110	1168.8-1167.8
		115	1179.4-1178.4
		120	1190.1-1189.1
		125	1200.3-1199.3
		130	1212.2-1211.2

11/30/22

11/30/22

Unit Startup

Before Powering Unit, Check the Following:

NOTE: Remove and discard the compressor hold down shipping bolt located at the front of the compressor mounting bracket.

- **Black/white and gray/white wires in unit control box have been removed if auxiliary heat has been installed.**
- **Dip switches are set correctly.**
- **Transformer switched to 208V if applicable.**
- **High voltage is correct and matches nameplate.**
- Fuses, breakers and wire size correct.
- Low voltage wiring complete.
- Piping completed and water system cleaned and flushed.
- Air is purged from closed loop system.
- Isolation valves are open, water control valves or loop pumps wired.
- Condensate line open and correctly pitched.
- Hot water generator pump switch is “OFF” unless piping is completed and air has been purged.
- Blower rotates freely.
- Blower speed is correct.
- Air filter/cleaner is clean and in position.
- Variable speed drive filter is clean and in place.
- Service/access panels are in place.
- Return air temperature is between 50-80°F heating and 60-95°F cooling.
- Check PinnaCoil™ air coil cleanliness to ensure optimum performance. Clean as needed according to maintenance guidelines. To obtain maximum performance the PinnaCoil™ air coil should be cleaned before startup. A 10-percent solution of dishwasher detergent and water is recommended for both sides of coil, a thorough water rinse should follow.

Powering The Controls

Initial Configuration of the Unit

Before operating the unit, apply power and complete the following Aurora Startup procedure for the controls configuration. An AID Tool is required for setup, configuration, and troubleshooting on the Variable Speed system. AID Tool version 2.09 or greater is preferred.

1. Configure Aurora Screen

- a. Confirm AXB is added and communicating.
- b. Confirm AOC is added and communicating.
- c. Confirm MOC is added and communicating.
- d. Confirm IntelliZone2 is added and communicating if installed. Set zoning system to OFF.
- e. Confirm communicating thermostat is added and communicating if IntelliZone2 is not installed. Set thermostat mode to OFF.

NOTE: The AOC and MOC are the two boards that comprise the VS drive.

2. Aurora Setup Screen

- a. ECM Setup for Heating Airflow – select G, low, high and aux blower speeds as appropriate for the unit and electric heat.
- b. Cooling Airflow % – sets the cooling airflow % from heating airflow. Factory setting is -15%
- c. AXB Setup
 - i. DHW Enable – Ensure air is purged from HW system before enabling (remember

the HW switch on the front cabinet)

- ii. DHW Setpoint – 130 °F is the default but can be changed from 100 to 140 °F
 - iii. Variable Speed Pump Setup and Modulating Water Valve Setup – Can be setup to a range between 6% and 100%. Defaults are 50% and 100%.
 - From the Main Menu of the AID Tool go to AXB Setup and select “Yes” at the bottom of the screen to Make Changes
 - Set VS Pump Control to MIN
 - The pump(s) or water valve should begin to operate and flow rate is visible on this screen, it may take several seconds for flow to stabilize. Adjust the minimum % until the minimum flow rate is achieved.
 - Go back to Set VS Pump Control and select MAX.
 - The pump(s) or water valve should begin to operate and flow rate is visible on this screen, it may take several seconds for flow to stabilize. Adjust the maximum % until the maximum flow rate is achieved.
 - Press Enter.
- d. Sensor Kit Setup
- i. Brine Selection – for HE/HR capacity calculation
 - ii. Flow Meter – activates the flow meter
 - iii. Pump - Select the correct flow center option using the table below. If using an open system select “Open Loop.” This selection is used to calculate the system pumping watts.
 - iv. Activate energy option
 - v. Select blower energy – PSC or ECM/5-Speed ECM
 - vi. Line Voltage calibration – Voltmeter required to calibrate line voltage during heating or cooling. Refer to Line Voltage Calibration in this manual for more details.
- e. Smart Grid Setup – Select action option for utility received On Peak signal
- f. Home Automation 1 and 2 Setup – Select type of sensor for two home automation inputs.

Sensor Kit Setup Screen in AID TOOL			
FC1	FC2	VS Pump	VS X2 Pump
FC1-GL	FC2-GL	FCV1B-GL	FCV2B-GL
FC1-FPT	FC2-FPT		
FC1-GLNP	FC2-GLNP	FCV1B-GLNPP	FCV2B-GLNPP
FC2-GLNPD	FC4-GLNPD		
FC3-GLNPD (right side)	FC3-GLNPD (left side)		
FCV2AB-GLNPD (right side)		FCV2AB-GLNPD (left side)	
		FCV2BB-GLNPD (right & left side)	
		FCV3CB-GLNPD (right side)	FCV3CB-GLNPD (left side)
			FCV4AB-GLNPD (right & left side)

Unit Startup cont.

Configuring the Sensor Kits

Configuring the Sensor kits

The Aurora Advanced Control allows Refrigeration, Energy, and Performance Monitoring sensor kits. These kits can be factory or field installed. The following description is for field activation of a factory installation of the sensor kits.

Energy Monitoring

The Energy Monitoring Kit includes two current transducers (fan and electric heat) added to the existing compressor drive sensor so that the complete power usage of the heat pump can be measured. The AID Tool provides configuration detail for the type of blower motor and a line voltage calibration procedure to improve the accuracy. This information can be displayed on the AID Tool or selected communicating thermostats. The TPCM32U04A will display instantaneous energy use while the color touchscreen TPCC32U Series will in addition display a 13 month history in graph form. Ensure the Energy Kit has been enabled by accessing the 'Sensor Kit Setup' in the AID Tool and complete the following:

- a. Select 'Blower Energy' – PSC or ECM/5-Speed ECM
- b. Activate 'Energy Option' to activate the sensors on for compressor (2), blower and aux heat current sensor.
- c. Select 'Pump' option of FC1, FC2, VS Pump, VS X2 Pump, VS + 26-99, or open loop. This selects the pump watts used in the calculation. Pump watts are measured on VS pumps and estimated on fixed speed pumps.
- d. Line Voltage Calibration – Voltmeter required to calibrate line voltage during heating or cooling.
 - i. Turn on Unit in Heating or Cooling .
 - ii. Use multimeter at L1 and L2 to measure line voltage
 - iii. In the Sensor Kit Setup screen adjust the 'Base Voltage' to the nearest value to that is measured
 - iv. Then use the 'Fine Adjust' to select the exact voltage being measured at L1 and L2.
 - v. Exit 'Sensor Setup' Screen
- e. Energy monitoring can be read on any of the following components:
 - i. AID Tool – instantaneous information only
 - ii. TPCM32U04A Communicating Thermostat (B/W) - instantaneous information only
 - iii. TPCC32U Series Thermostat – Both Instantaneously and historical (13 months)
 - iv. Web Portal via AWL device connected to Aurora

Refrigerant Monitoring

The Refrigerant Monitoring Kit includes two pressure transducers, and three temperature sensors, heating liquid line, suction temperature, and existing cooling liquid line (FP1). These sensors allow the measurement of discharge and suction pressures, suction and liquid line temperatures as well as superheat and subcooling. This information will only be displayed on the AID Tool. Ensure the Refrigerant Monitoring has been setup by accessing the 'Sensor Kit Setup' in the AID Tool and complete the following:

Once sensors are installed for discharge pressure, suction pressure, suction, liquid line cooling, liquid line heating, and leaving air temperature no further setup is required.

- a. Turn on unit in Heating or Cooling.
- b. Use the AID Tool to view the refrigerant performance in the 'Refrigerant Monitor' screen.
- c. Refrigerant monitoring can be read on any of the following components:
 - i. AID Tool – instantaneous information only
 - ii. WF Web Portal via AWL device connected to Aurora

Performance Monitoring

The optional Performance Monitoring Kit includes three temperature sensors, entering and leaving water, leaving air temperature and a water flow rate sensor. With this kit heat of extraction and rejection will be calculated. This requires configuration using the AID Tool for selection of water or antifreeze. Ensure the Performance Kit has been enabled by accessing the 'Sensor Kit Setup' in the AID Tool and complete the following:

- a. Select 'Brine' – and then choose Water or Antifreeze for the proper factor
- b. Activate 'Flowmeter' to activate the flow sensor select the appropriate 3/4 in., 1 in., or none (1 in. is standard on variable speed units).
- c. Exit 'Sensor Kit Setup' screen.
 - i. Enter the AXB Setup Screen and turn the VS Pump Control ON
 - ii. Then set the VS Pump Min % to achieve at least 2.5 gpm per ton for part load operation.
 - iii. Then set the VS Pump Max % to achieve at least 3.0 gpm per ton for full load operation.
- d. Turn on unit in Heating or Cooling.
- e. Use the AID Tool to view the performance in the 'Performance Monitor' screen.
- f. Performance monitoring can be read on any of the following components:
 - i. AID Tool – instantaneous information only
 - ii. Web Portal via AWL device connected to Aurora

Startup Steps

NOTE: Complete the Equipment Startup/Commissioning Check Sheet during this procedure. Refer to thermostat operating instructions and complete the startup procedure. Verify that the compressor shipping bolt has been removed.

1. Initiate a control signal to energize the blower motor. Check blower operation through the AID Tool.
2. For MHGR option, navigate to the Hot Gas Reheat screen on the AID Tool. Then set Valve position to OFF to completely close off the reheat circuit before proceeding to the next step. **NOTE: FAILURE TO DO THIS WILL PREVENT ACCURATE PERFORMANCE VERIFICATION OF THE SYSTEM.**
3. Initiate a control signal to place the unit in the cooling mode. Cooling setpoint must be set below room temperature.

Unit Startup cont.

4. First stage cooling will energize after a time delay.
5. Be sure that the compressor and water control valve or loop pump(s) are activated.
6. Verify that the water flow rate is correct by measuring the pressure drop through the heat exchanger using the P/T plugs and comparing to unit performance data in catalog or view on the AID Tool if Performance Kit is installed.
7. Check the temperature of both the supply and discharge water (see the Unit Operating Parameters tables).
8. Check for an air temperature drop of 15°F to 25°F across the air coil (cooling compressor speed 9), depending on the blower speed and entering water temperature.
9. Decrease the cooling set point several degrees and verify high-speed blower operation.
10. Adjust the cooling setpoint above the room temperature and verify that the compressor and water valve or loop pumps deactivate.
11. Initiate a control signal to place the unit in the heating mode. Heating set point must be set above room temperature.
12. First stage heating will energize after a time delay.
13. Check the temperature of both the supply and discharge water (see the Unit Operating Parameters tables).

Operating Limits

Operating Limits	Cooling		Heating	
	(°F)	(°C)	(°F)	(°C)
Air Limits				
Min. Ambient Air	45	7.2	45	7.2
Rated Ambient Air	80	26.7	70	21.1
Max. Ambient Air	100	37.8	85	29.4
Min. Entering Air	50	10.0	40	4.4
Rated Entering Air db/wb	80.6/66.2	27/19	68	20.0
Max. Entering Air db/wb	110/83	43/28.3	80	26.7
Water Limits				
Min. Entering Water	30	-1.1	20	-6.7
Normal Entering Water	50-110	10-43.3	30-70	-1.1
Max. Entering Water	120	48.9	90	32.2

NOTE: Minimum/maximum limits are only for start-up conditions, and are meant for bringing the space up to occupancy temperature. Units are not designed to operate at the minimum/maximum conditions on a regular basis. The operating limits are dependent upon three primary factors: 1) water temperature, 2) return air temperature, and 3) ambient temperature. When any of the factors are at the minimum or maximum levels, the other two factors must be at the normal level for proper and reliable unit operation.

Preventative Maintenance

Water Coil Maintenance

1. Keep all air out of the water. An open loop system should be checked to ensure that the well head is not allowing air to infiltrate the water line. Lines should always be airtight.
2. Keep the system under pressure at all times. It is recommended in open loop systems that the water control valve be placed in the discharge line to prevent loss of pressure during off cycles. Closed loop systems must have positive static pressure.

NOTE: On open loop systems, if the installation is in an area with a known high mineral content (125 PPM or greater) in the water, it is best to establish with the owner a periodic maintenance schedule so the coil can be checked regularly. Should periodic coil cleaning be necessary, use standard coil cleaning procedures which are compatible with either the cupronickel or copper water lines. Generally, the more water flowing through the unit the less chance for scaling.

Other Maintenance

Filters

Air filters and variable speed drive filter must be clean to obtain maximum performance. They should be inspected monthly under normal operating conditions and be replaced when necessary. Units should never be operated without a filter. The VS drive filter is located on the lower left corner of the cabinet. Removing the two screws in the honey comb grill allows access to the filter. Run the filter under warm water and gently rub. Let the filter dry. The, re-install the filter and cover.

Condensate Drain

In areas where airborne bacteria produce a slime in the drain pan, it may be necessary to treat chemically to minimize the problem. The condensate drain can pick up lint and dirt, especially with dirty filters. Inspect twice a year to avoid the possibility of overflow.

Preventative Maintenance cont.

Blower Motors

ECM blower motors are equipped with sealed ball bearings and require no periodic oiling.

Hot Water Generator Coil

See Water Coil Maintenance section above.

PinnaCoil™ Air Coil

The air coil must be cleaned to obtain maximum performance. Check once a year under normal operating conditions and, if dirty, brush or vacuum (with a brush attachment) clean. Care must be taken not to damage the aluminum fins while cleaning.



CAUTION: Fin edges are sharp.

Replacement Procedures

Obtaining Parts

When ordering service or replacement parts, refer to the model number and serial number of the unit as stamped on the serial plate attached to the unit. If replacement parts are required, mention the date of installation of the unit and the date of failure, along with an explanation of the malfunctions and a description of the replacement parts required.

In-Warranty Material Return

Material may not be returned except by permission of authorized warranty personnel. Contact your local distributor for warranty return authorization and assistance.

Troubleshooting

Aurora Control System

NOTE: Refer to the Aurora Base Control Application and Troubleshooting Guide and the Instruction Guide: Aurora Interface and Diagnostics (AID) Tool for additional information.

To check the unit control board for proper operation:

1. General Check
 - If any new device was installed, or any wiring was changed, check the connections to ensure the wiring is correct, and all the wires are in good condition.
 - Verify all the plugs are securely connected and in good condition.
 - Check the DIP switch (SW2) positions are correct.
 - Measure 24 VAC between R and C. (The actual reading may be from 18 to 30 VAC). Check the incoming power and the power transformer if the R and C voltage reading is not correct.
2. No LEDs are On
 - Check 24 VAC on board.
 - Check the 3 amp fuse. Replace the fuse if needed.
 - Verify transformer circuit breaker has not tripped if no low voltage is present.
 - Disconnect the thermostat connection P1.
 - Replace the Aurora base control board.

Refrigerant Systems

Refrigerant pressures are monitored by the control system; to maintain sealed circuit integrity, do not install service gauges unless pressure sensor is suspected to be inoperative. Compare the change in temperature on the air side as well as the water side to the Unit Operating Parameters tables. If the unit's performance is not within the ranges listed, make sure the airflow and water flow are correct. Check superheat and subcooling with an AID Tool. If superheat and subcooling are outside recommended ranges, an adjustment to the refrigerant charge may be necessary.

NOTE: Refrigerant tests must be made with hot water generator turned "OFF". Verify that air and water flow rates are at proper levels before servicing the refrigerant circuit.

Aurora Interface Diagnostic (AID) Tool

Aurora Input-Output Diagnostics



Troubleshooting the Aurora logic board can be accomplished using nothing more than a couple of jumper wires and a volt meter. The process can be simplified with the use of the Aurora Interface Diagnostic Tool (AID Tool). The AID Tool allows the user to see lockout and fault history information, thermostat inputs, sensor inputs, system outputs, timer, etc.

Aurora ABC Checkout

Before replacing the Aurora ABC control board the proper troubleshooting steps must be taken to ensure that the board is the root cause. On the following pages are several flow charts that will assist in checking the control board. If it is found that the control board is faulty, contact technical services for a replacement part.

Blower Speed Selection Number	PWM %	Dehumidification PWM %
1	2	2
2	11	3
3	19	9
4	31	20
5	41	28
6	52	37
7	60	44
8	68	51
9	78	59
10	89	69
11	95	74
12	98	76

LED Displays

Slow Flash = 1 second on and 1 second off

Fast Flash = 100 ms on and 100 ms off

Flash Code = 100 ms on and 400 ms off with a 2 second pause between packages

SW1 Operation

Holding SW1	Description of Operation	LED
2 to 5 sec	Enter Test Mode	Green LED Slow Flash
5 to 10 sec	Enter ECM Configure Mode	Yellow LED Off
50 to 60 sec	Reset Configure Mode (default)	Yellow LED Off
> 60 sec	SW1 Operation Cancel	Yellow LED Back to Normal

“SW1 operation cancel,” holding SW1 for longer than 60 seconds operation will be cancelled. Yellow LED will go back to normal operation.

Fault Retries Before Lockout

Type of Fault	Total Tries Before Lockout
High Pressure	3 Retries
Low Pressure	3 Retries
Freeze Detection 1 - (Coax)	3 Retries
Freeze Detection 2 - (Air coil)	3 Retries
Condensate Overflow	3 Retries
Over/Under Voltage Shutdown	No Lockout
Compressor Monitor	No Retry
Freeze Detection Sensor Error (Sensor is out of range)	No Retry

Preliminary Checkout Procedure

Troubleshooting liquid source heat pumps with Aurora controls is an easy and straight forward process. Most service problems are related to water flow (insufficient or too cold). Also, most service problems can be fixed without connecting refrigerant manifold gauges.

The first item to check is system performance which can be done in six steps. Before beginning make sure the hot water generator pump is disconnected.

STEP 1: Check and/or set source water flow. Refer to the install manual for the specific piece of equipment’s correct water flow setting.

STEP 2: Check the temperature difference through the coaxial heat exchanger and compare to the Operating Parameters table in the equipment install manual.

STEP 3: Check the air temperature rise/drop and compare to the Operating Parameters table in the equipment’s installation manual.

STEP 4: If the first three steps check out, perform a heat of extraction/rejection test as described in the Water Side Analysis: Heat of Extraction/Rejection section to confirm proper operation.

STEP 5: If any or all of the above steps do not check out, be sure that the air coil and filter are clean.

STEP 6: Check superheat and subcooling by placing refrigeration gauges on the unit. Compare superheat and subcooling values with the charts in the equipment installation manual.

If the above six steps do check out, it would be safe to assume that the unit is performing well and the problem must lie elsewhere, i.e. excessive heat loss/gain in the structure or duct system, (undersized duct and/or registers, etc.)

If you suspect a specific problem, refer to the Table of Contents and select the reference that most closely matches the situation encountered. If problems persist after completing the preliminary checkout procedure, refer to the Troubleshooting Checklist. Select the problem which is closest to the situation you have encountered.

Troubleshooting Checklist

Equipment will not start or operate

- Follow the troubleshooting flow charts to find root cause.

High pressure lockout in the heating mode

- Check for air flow interruption from one or more of the following: inoperative blower, dirty filters or air coil, blocked return air grill, closed or blocked supply registers, restricted supply or return duct, zone dampers, etc. If airflow is suspected as being a problem, make a quick check using the following example: Velocity in a supply duct should not exceed 1000 fpm and 700 fpm in return ducts. For this example we will use a Variable Speed Q36 which has a maximum rating of 1575 cfm at 0.50 static (Refer to the blower performance tables in the install manual for your particular piece of equipment). Using the formula: Area in square feet equals quantity in cfm divided by velocity in fpm ($A = \text{cfm}/\text{fpm}$), 1.57 sq. ft. is needed for the supply duct and 2.25 sq. ft. is needed for the return duct. Refer to the troubleshooting flow charts if a problem with the blower motor or logic board is suspected.
- Check for EEV operation. EEV opening percentage should change as compressor speed changes.
- Make sure the discharge pressure is within the operating range shown in the product install manual.
- The unit may be overcharged; check superheat and sub cooling. If this problem is verified, recharge using approved methods.

High pressure lockout in the cooling mode

- Water flow may be restricted or inadequate. Verify in accordance with the pressure drop tables shown in product install manual. Also, look for the following: solenoid valve may not be opening on well water units, pump(s) may be inoperative in the flow center, debris may be blocking coil (back flush using at least 20 PSI), or air may be in the loop (flush loop). Variable speed pump may not be setup properly.
- Water to refrigerant heat exchanger may be fouled with debris. If so, back flush with at least 20 psi of water pressure.
- If mineral accumulation is evident, clean the heat exchanger with acid.
- Entering air temperature may be too high. Equipment is designed for a maximum of 85°F DB and 71°F WB.
- Check for EEV operation. EEV opening percentage should change as compressor speed changes.
- The unit may be overcharged; check superheat and sub cooling. If this problem is verified, recharge using approved methods.

Low pressure lockout in heating mode

- If equipment is installed in a low temperature area (below 50°F), install a crankcase heater, then protect the unit from the elements.

- Water flow may be restricted or inadequate. Verify in accordance with the pressure drop tables shown in product install manual. Also, look for the following: solenoid valve may not be opening on well water units, pump(s) may be inoperative in the flow center, debris may be blocking coil (back flush using at least 20 PSI), or air may be in the loop (flush loop). Variable speed pump may not be setup properly.
- Check for EEV operation. EEV opening percentage should change as compressor speed changes.
- Return air temperature may be below 50°F. Block off air coil temporarily to improve flow of refrigerant through the system. Air below 50°F cannot be tolerated on a continuing basis. Correct the problem.
- Refrigerant may be low. Check for leaks, reclaim refrigerant, repair if necessary, recharge using approved methods.

Low pressure lockout in the cooling mode

- Check for inadequate air flow. Follow the same procedure as shown for a high pressure lockout in the heating mode.
- Check for EEV operation. EEV opening percentage should change as compressor speed changes.
- Refrigerant charge may be low.

Freeze detection lockout in either the heating or cooling mode

- Water flow may be restricted or inadequate. Verify in accordance with the pressure drop tables shown in product install manual. Also, look for the following: solenoid valve may not be opening on well water units, pump(s) may be inoperative in the flow center, debris may be blocking coil (back flush using at least 20 PSI), or air may be in the loop (flush loop). Variable speed pump may not be setup properly.
- Disconnect freeze sensor from control and measure the resistance. Cross reference with the Thermistor Data table.
- Airflow may be inadequate.

Condensate over flow lockout in either the heating or cooling mode

- Make sure the drain line pitches away from the unit. Install a vertical vent on horizontal drain lines over six feet long. Clean condensate pan and be sure outlet and drain line from the condensate pan is clear.

Reversing valve does not operate

- Disconnect solenoid and check for continuity across coil. Replace coil if continuity is not found.
- If stuck reversing valve is suspected, restrict airflow in heating mode (to build pressure), then switch immediately to the cooling mode.

Control Board Troubleshooting Steps

1) General Check

- If any new device was installed, or any wiring was changed, check the connections to ensure the wiring is correct, and all the wires are in good condition.
- Verify all the plugs are securely connected and in good condition.
- Check the DIP switch (SW2) positions are correct.
- Measure 24 VAC between R and C. (The actual reading may be from 18 to 30 VAC). Check the incoming power and the power transformer if the R and C voltage reading is not correct.

2) No LEDs are On

- Check 24 VAC on board.
- Check the 3 amp fuse. Replace the fuse if needed.
- Verify transformer circuit breaker has not tripped if no low voltage is present.
- Disconnect the thermostat connection P1.
- Replace the Aurora base control board.

3) Red LED Flash Code

Input Fault (Code 1) – Indicates that both O and W input signals are present. Disconnect the thermostat connector from the ABC board and then cycle power to the board. If the fault does not reappear, then the problem is between the thermostat and the thermostat connector. Otherwise, replace the ABC board.

High Pressure Fault (Code 2) – Indicates the system pressure has exceeded 600 psi (R-410A) which may have been caused by low water flow in cooling, (check coaxial heat exchanger for mineral build-up) or low air flow in heating (check filters and coil for dirt build-up). Measure P4-9 and C is 24 VAC. If not, replace ABC. Check the heat pump refrigeration system. Cycle the power to reset the system. Measure P4-10 and C is 24 VAC. If not, replace the high pressure sensor.

Low Pressure Fault (Code 3) – Indicates low pressure switch has opened which may indicate a loss of system charge, system restriction, or frozen heat exchanger. Measure P4-7 and C is 24 VAC. If not, replace ABC. Check the heat pump refrigeration system. Cycle the power to reset the system. Measure P4-8 and C is 24 VAC. If not, replace the low pressure sensor. Refrigerant may be low. Check for leaks, reclaim refrigerant, repair if necessary, pump down and recharge the system to the quantity of refrigerant shown on the unit nameplate.

Freeze Detection 1 Fault (Code 5) – Indicates low or no water flow; low system charge; or faulty EEV in heating mode. Make sure the DIP switch FP1 (SW2-1) selection matches the application. Measure the temperature on the refrigerant line next to the freeze detection thermistor. Disconnect the connector P4. Measure the resistance reading between P4-3, P4-4. Refer to the Thermistor Data table, find the corresponding temperature data. Compare the data with the temperature

measurement from the refrigerant line. The temperature should be within +/- 2° F. If not, replace the thermistor.

Other items to check when troubleshooting a water flow lockout are superheat, water flow through the coaxial heat exchanger and antifreeze composition. High superheat in heating will lower the refrigerant line temperature where the freeze detection thermistor is located. In this case, check the EEV. Closed loop systems are rated at 3 gpm/ton. If a closed loop system is running at less than 3 gpm/ton, the temperature difference between the refrigerant line and the actual leaving water temperature will be greater and could lead to possible water flow lockouts.

Condensate Fault (Code 7) – Indicates condensate water in the drain pan fills up and touches the spade terminal. Make sure the drain line pitches away from the unit. Install a vertical vent on horizontal drain lines over six feet long. Clean and be sure outlet and drain line from the condensate pan is clear. Start the system in cooling. Observe the water level in the drain pan. If the unit is locking out on condensate and the drain pan is dry, remove the condensate wire from the drain pan and tape it out of the way. Be careful to not ground the wire out because that will cause the unit to lockout on drain overflow. If the unit is still locking out, check the brown wire all the way back to the ABC for a short to ground. Remember that the condensate sensor is just a wire looking for a ground. If it touches any metal in the cabinet, the unit will see that as a drain fault. If removing the wire from the drain pan stopped the false drain lockouts, put the condensate sensor back in place in the drain pan. Pay close attention to how far the spade terminal sits down in the drain pan. If the terminal is pushed all the way down so that it is touching the bottom of the drain pan, this will cause a drain lockout if there is any trace of water. If the spade terminal fits loosely in the drain pan, spread the terminal open to make it fit snugly in the drain pan.

Over/Under Voltage Shutdown Fault (Code 8) – Indicates the control voltage is or had been outside the range of 18 to 30 VAC for more than 15 minutes. Using a voltage meter, check the incoming power line voltage is within + or - 25%. If not, there is a power line issue. Check the secondary of the control transformer with a voltage meter. The voltage should be 18 to 30 VAC. If not, replace the control transformer.

Freeze Detection FP1 Sensor Fault (Code 11) – Indicates the freeze detection sensor is out of range. Disconnect the connector P4. Measure the resistance reading between P4-3, P4-4. Refer to the Thermistor Data table, find the corresponding temperature data. Compare the data with the temperature measurement from the refrigerant line. The temperature should be within +/- 2°F. If not, replace the thermistor.

Control Board Troubleshooting Steps

4) Other Faults

ECM Motor Will Not Start

1. Measure the voltage output between P13-1 and P13-5. Reference the following table for blower speed vs. voltage.

Blower Speed Selection Number	DC Volts
1	0.6 VDC
2	2.7 VDC
3	4.6 VDC
4	7.5 VDC
5	9.8 VDC
6	12.5 VDC
7	14.4 VDC
8	16.3 VDC
9	18.5 VDC
10	21.2 VDC
11	22.3 VDC
12	23.4 VDC

2. Measure the voltage from C to F terminals (P5-2). The reading should be 24VAC.

Compressor First Stage Will Not Start - See the Flow Chart.

No Alarm Output - Measure the voltage output between P2-4 and C. The reading should be 24 VAC or a pulsed 24 VAC dependent on the selection of SW2-7.

Accessory Relay Does Not Operate - Measure the continuity between P2-2 and P2-3. It should read closed when relay is engaged. If this is not correct, check SW2-4 and SW2-5 settings.

No Lockout Output - Measure the voltage output between P1-1 and C. The reading should be 24 VDC or a pulsed 24 VDC dependent on the selection of SW2-7. If voltage is not present, make sure the unit is in lockout and not fault retry.

Auxiliary Heater Does Not Function - Measure the voltage output between P3-1, P3-2, and P3-3, P3-4. The output should be 24 VDC. If voltage is not present, check thermostat operation and wiring.

Loop Pump Does Not Start - The loop pump is controlled by the AXB board. Check to make sure the control board is powered by taking a voltage reading across R and C to check for 24VAC. If 24VAC is not present check the wiring connections, 24VAC is supplied to the AXB through the harness connected to P9. Next check to make sure the ABC is attempting to run the compressor, the loop pump will only run when the ABC is commanding CC on, the pump slave input is active, or the AXB has lost communication with the ABC. Please refer to troubleshooting flow charts for additional checks on the loop pump.

5) Thermistor

Disconnect the thermistor from the board and measure ohms. Compare the ohms reading to the thermistor data chart in this manual. If the thermistor reads open or shorted the thermistor is bad and should be replaced.

6) Pressure Transducer

Check to make sure the board is powering the transducer by checking for 5VDC between the brown and blue wires. If the reading is 0VDC the transducer is not being powered and the board should be replaced. If there is 5VDC present the transducer is powered and the output should be checked. To check the output, measure the DC voltage between the brown and black wires. The value should be between 0.3VDC and 4.5VDC. If it is outside of this range the transducer should be replaced.

7) Flow Meter

Check to make sure the board is powering the transducer by checking for 5VDC between the brown and green wires. If the reading is 0VDC the transducer is not being powered and the board should be replaced. If there is 5VDC present the transducer is powered and the output should be checked. To check the output, measure the DC voltage between the brown and white wires. The value should be between 0.3VDC and 3.3VDC. If it is outside of this range the transducer should be replaced.

8) Current Transducer

Disconnect the current transducer from the board and measure ohms across the two wires. The ohms reading should be approx. 22 ohms.

Control Board Troubleshooting Flow Charts cont.

Use the following flow charts to aid in troubleshooting the control board.

Compressor Will Not Start Without AID Tool

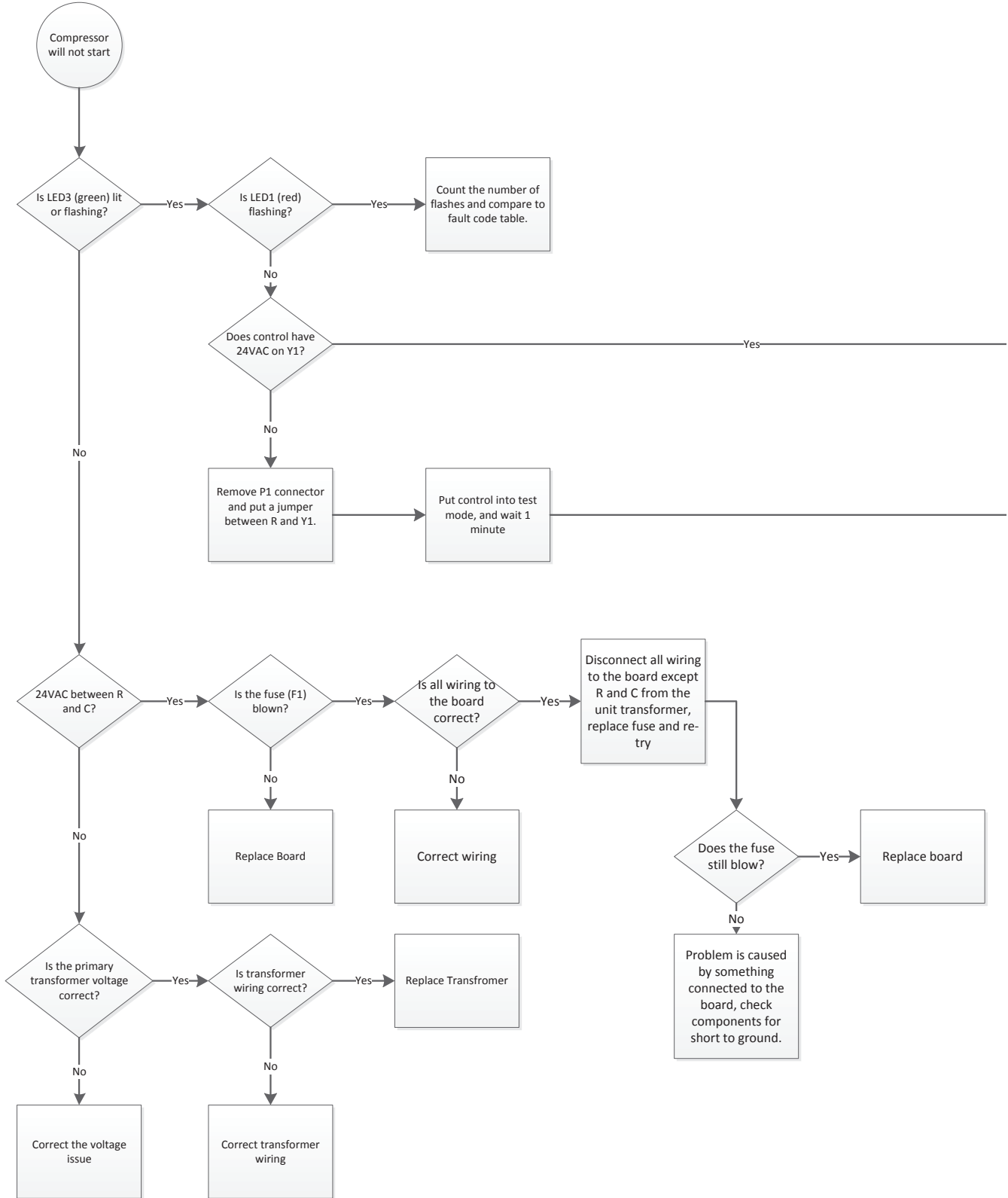

Control Board Troubleshooting Flow Charts cont.

Notes:

1. When measuring 24VAC actual value may be between 18 and 30VAC.

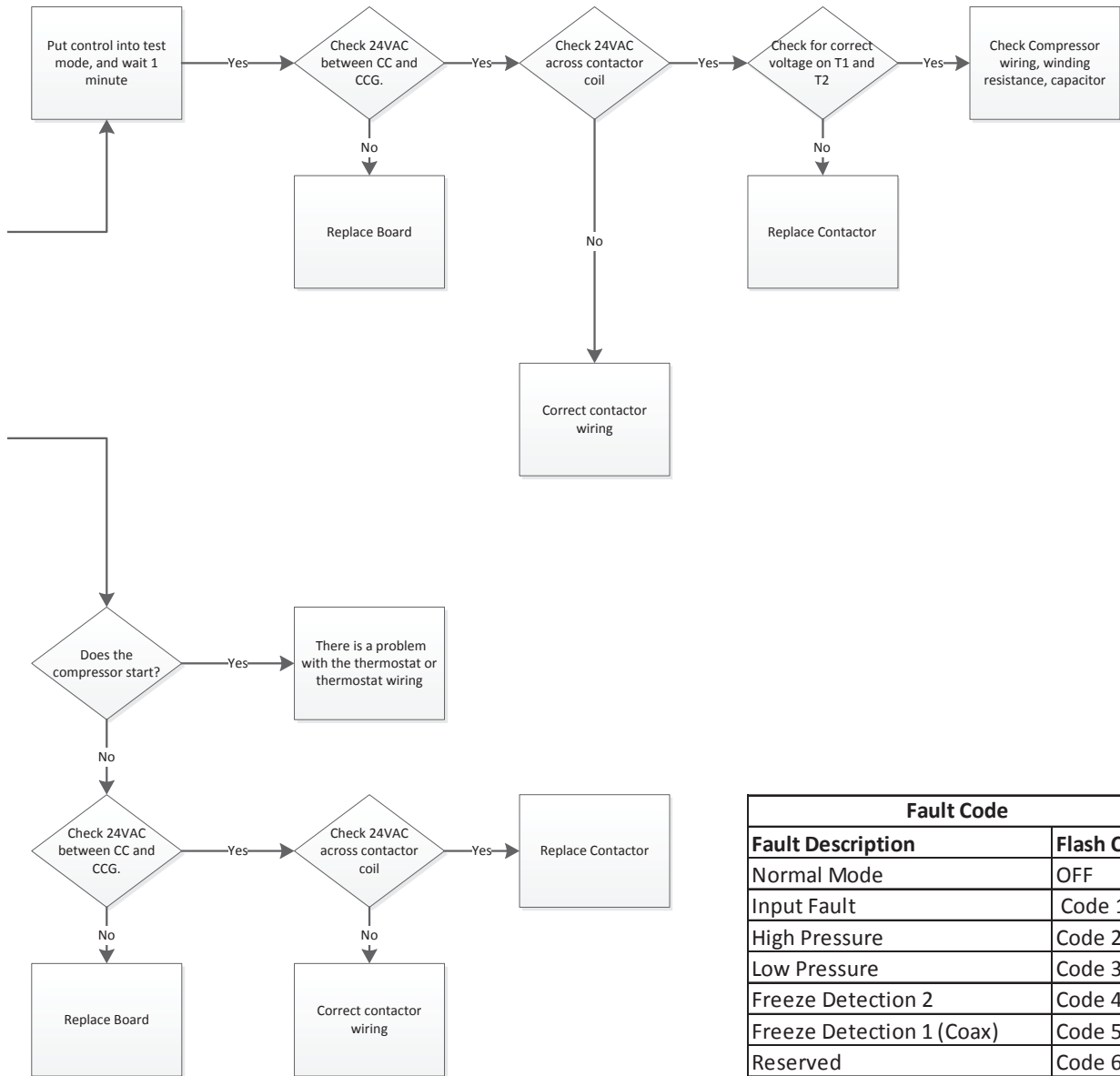

Fault Code	
Fault Description	Flash Code
Normal Mode	OFF
Input Fault	Code 1
High Pressure	Code 2
Low Pressure	Code 3
Freeze Detection 2	Code 4
Freeze Detection 1 (Coax)	Code 5
Reserved	Code 6
Condensate	Code 7
Over/Under Voltage	Code 8
Not Used	Code 9
Freeze Detection Sensor Error	Code 11

NOTE: Refer to the Control Board Troubleshooting Steps for fault descriptions.

Control Board Troubleshooting Flow Charts cont.

Compressor Will Not Start With AID Tool

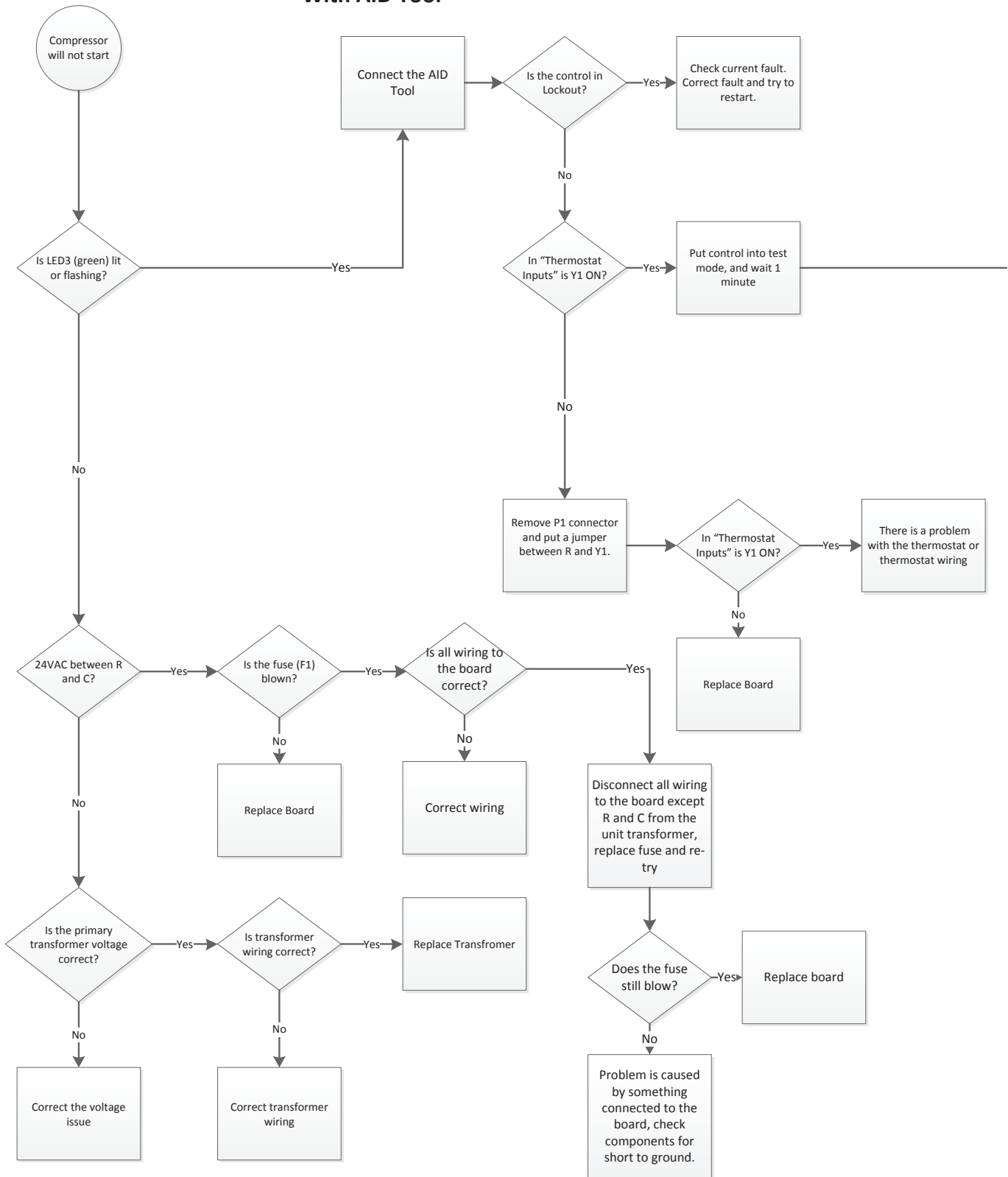

Control Board Troubleshooting Flow Charts cont.

Notes:

1. When measuring 24VAC actual value may be between 18 and 30VAC.

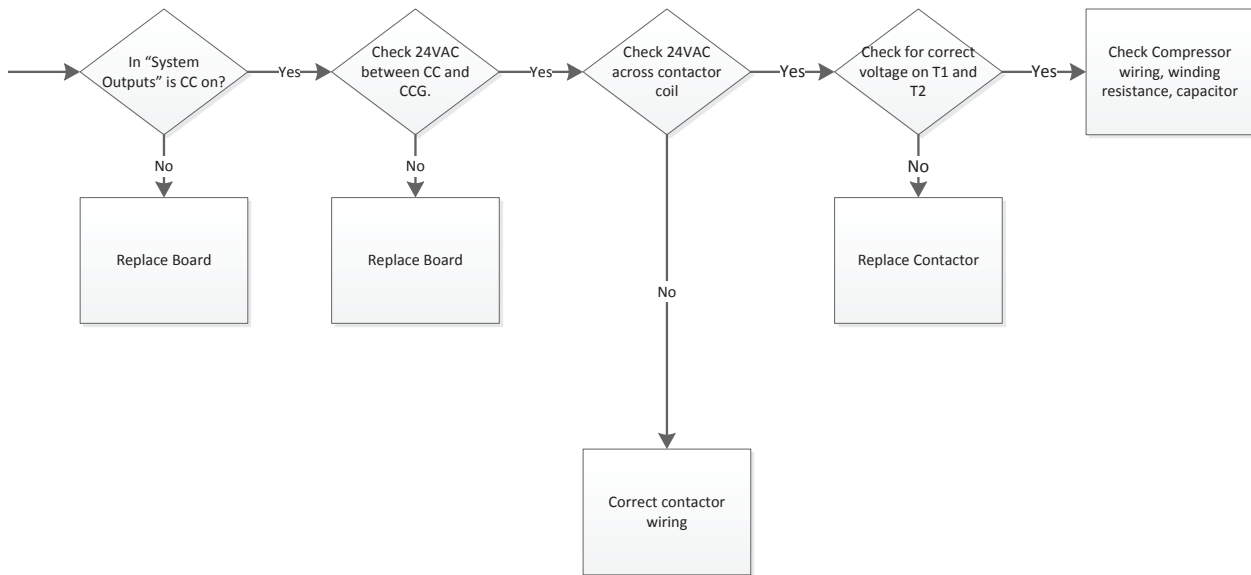

Control Board Troubleshooting Flow Charts cont.

ECM Blower Will Not Start Without AID Tool

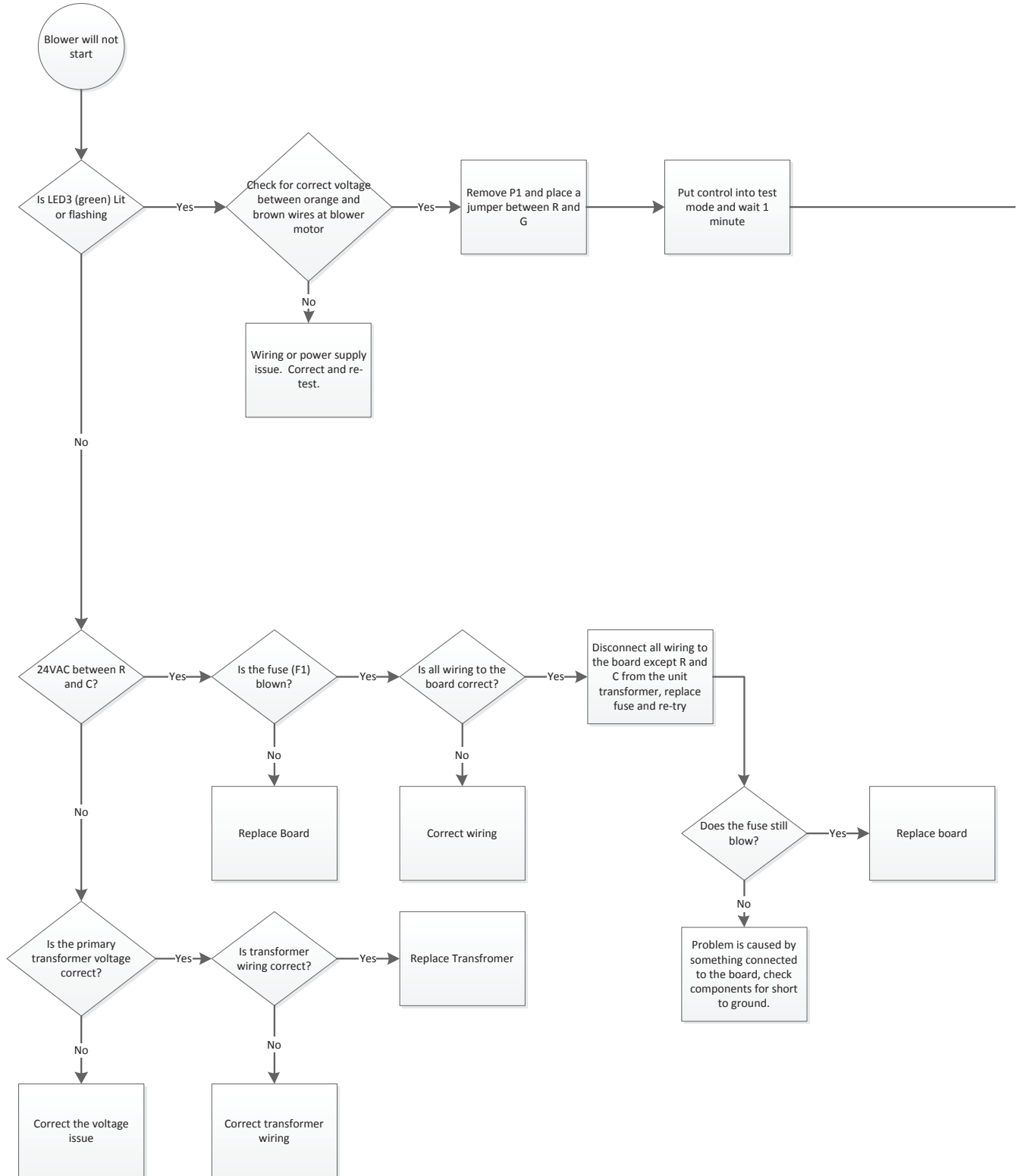

Control Board Troubleshooting Flow Charts cont.

Notes:

- 1. When measuring 24VAC actual value may be between 18 and 30VAC.

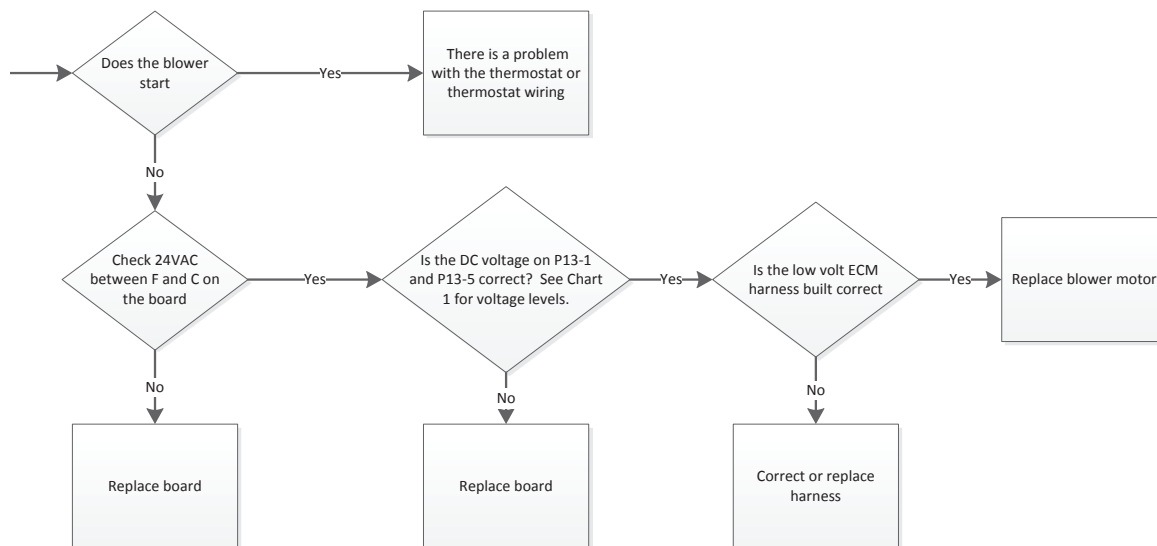

Chart 1

Blower Speed Selection Number	DC Volts
1	0.6VDC
2	2.7VDC
3	4.6VDC
4	7.5VDC
5	9.8VDC
6	12.5VDC
7	14.4VDC
8	16.3VDC
9	18.5VDC
10	21.2VDC
11	22.3VDC
12	23.4VDC

Control Board Troubleshooting Flow Charts cont.

ECM Blower Will Not Start With AID Tool



Control Board Troubleshooting Flow Charts cont.

Notes:

1. When measuring 24VAC actual value may be between 18 and 30VAC.

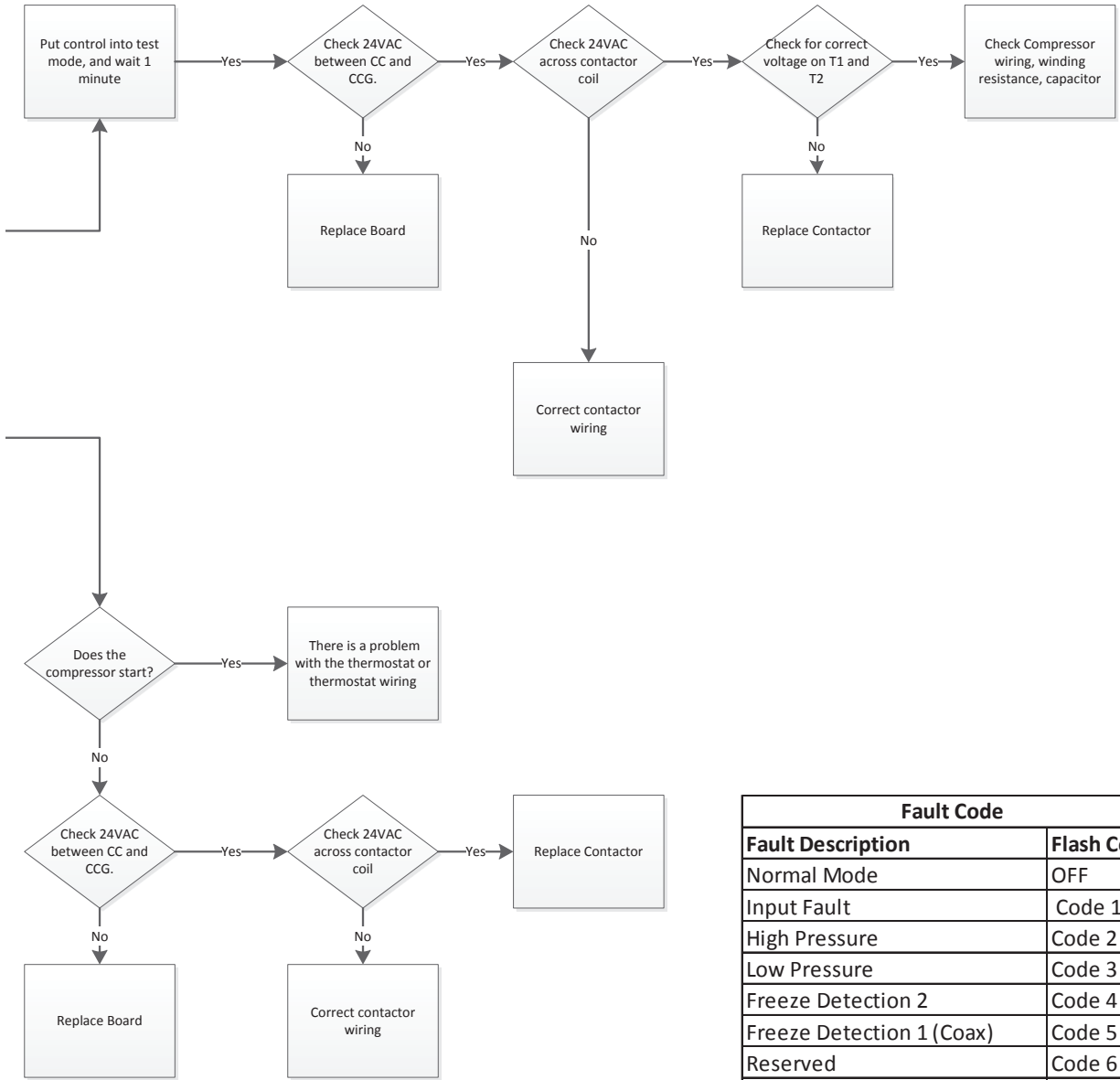

Fault Code	
Fault Description	Flash Code
Normal Mode	OFF
Input Fault	Code 1
High Pressure	Code 2
Low Pressure	Code 3
Freeze Detection 2	Code 4
Freeze Detection 1 (Coax)	Code 5
Reserved	Code 6
Condensate	Code 7
Over/Under Voltage	Code 8
Not Used	Code 9
Freeze Detection Sensor Error	Code 11

Control Board Troubleshooting Flow Charts cont.

Loop Pump Will Not Start Variable Speed Pump

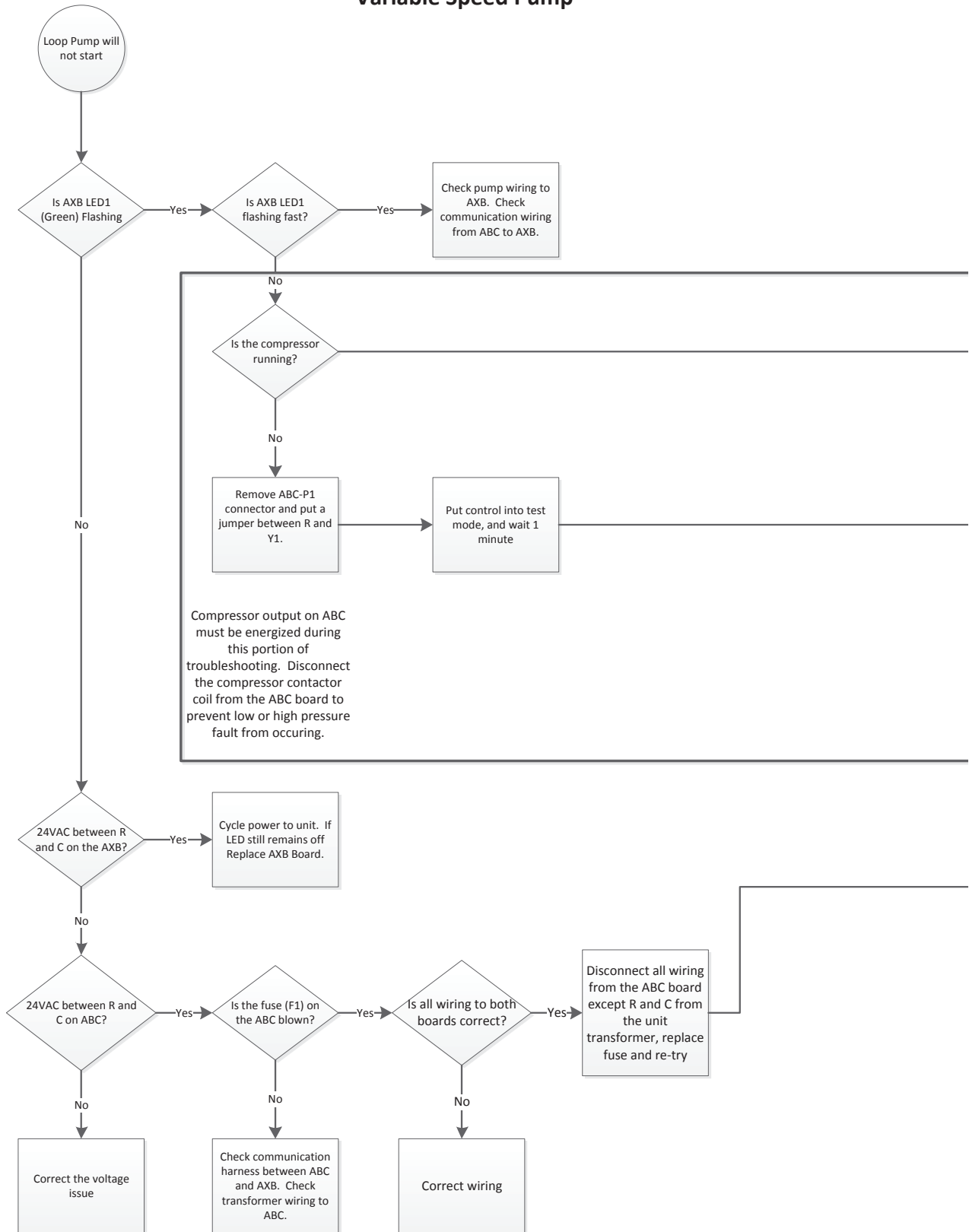

Control Board Troubleshooting Flow Charts cont.

Notes:

1. When measuring 24VAC actual value may be between 18 and 30VAC.
2. When measuring 240VAC actual value may be between 190 and 250 VAC.

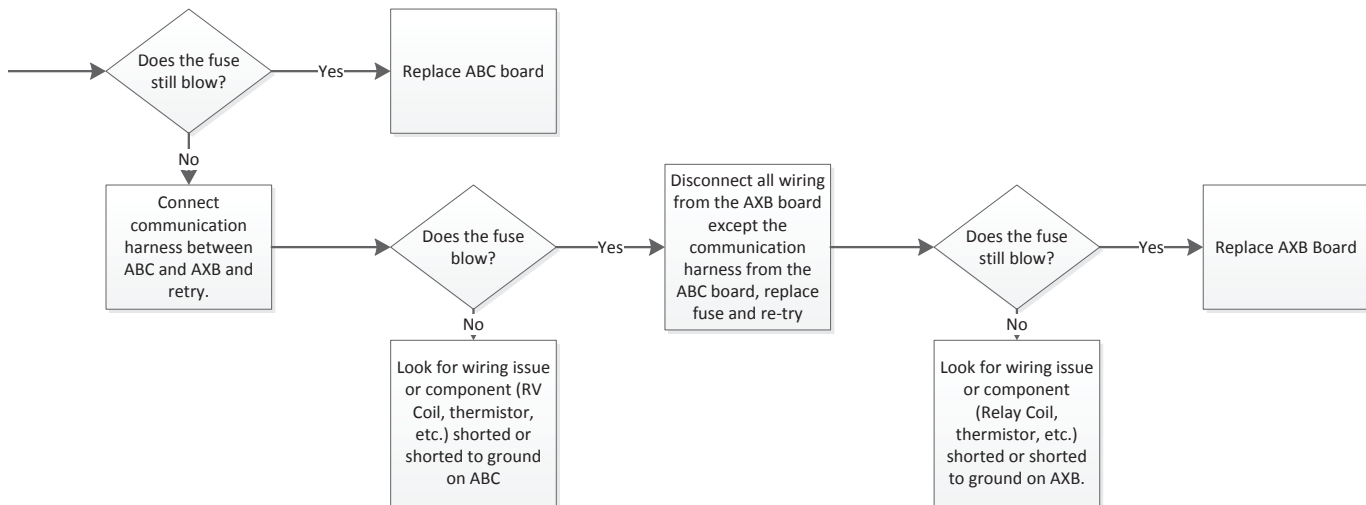
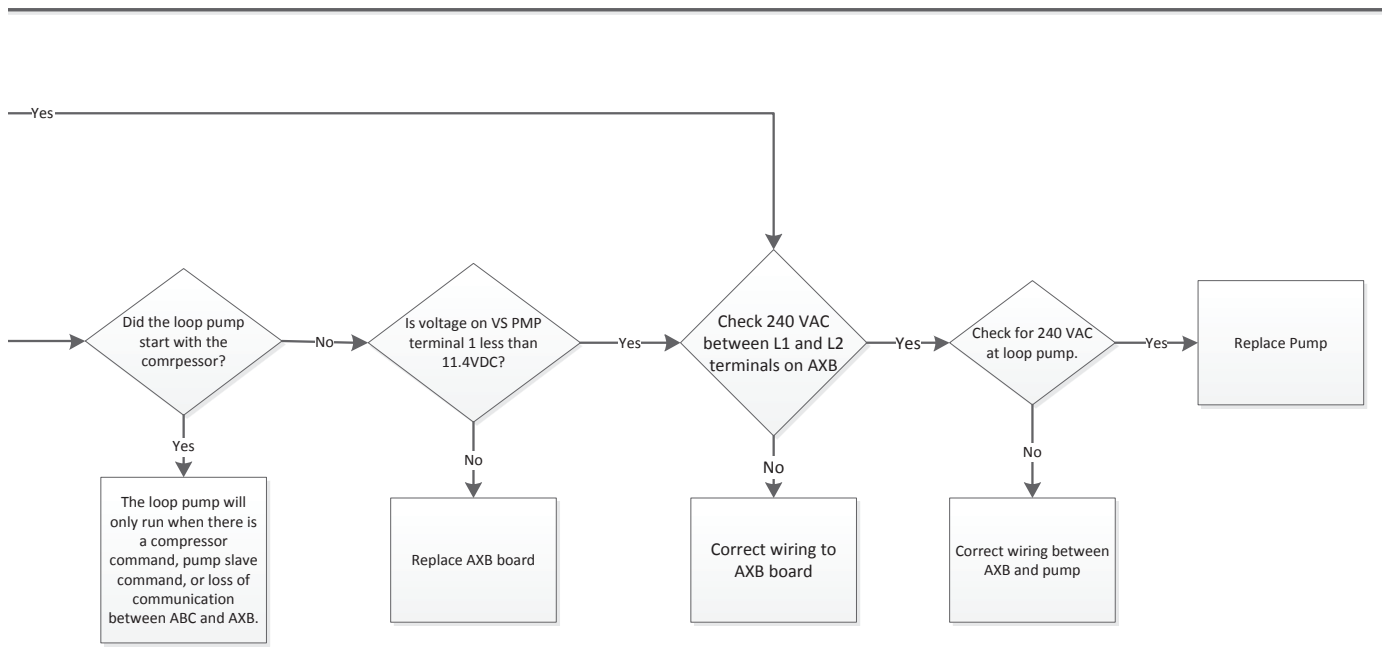

Control Board Troubleshooting Flow Charts cont.

Loop Pump Will Not Start Non Variable Speed Pump

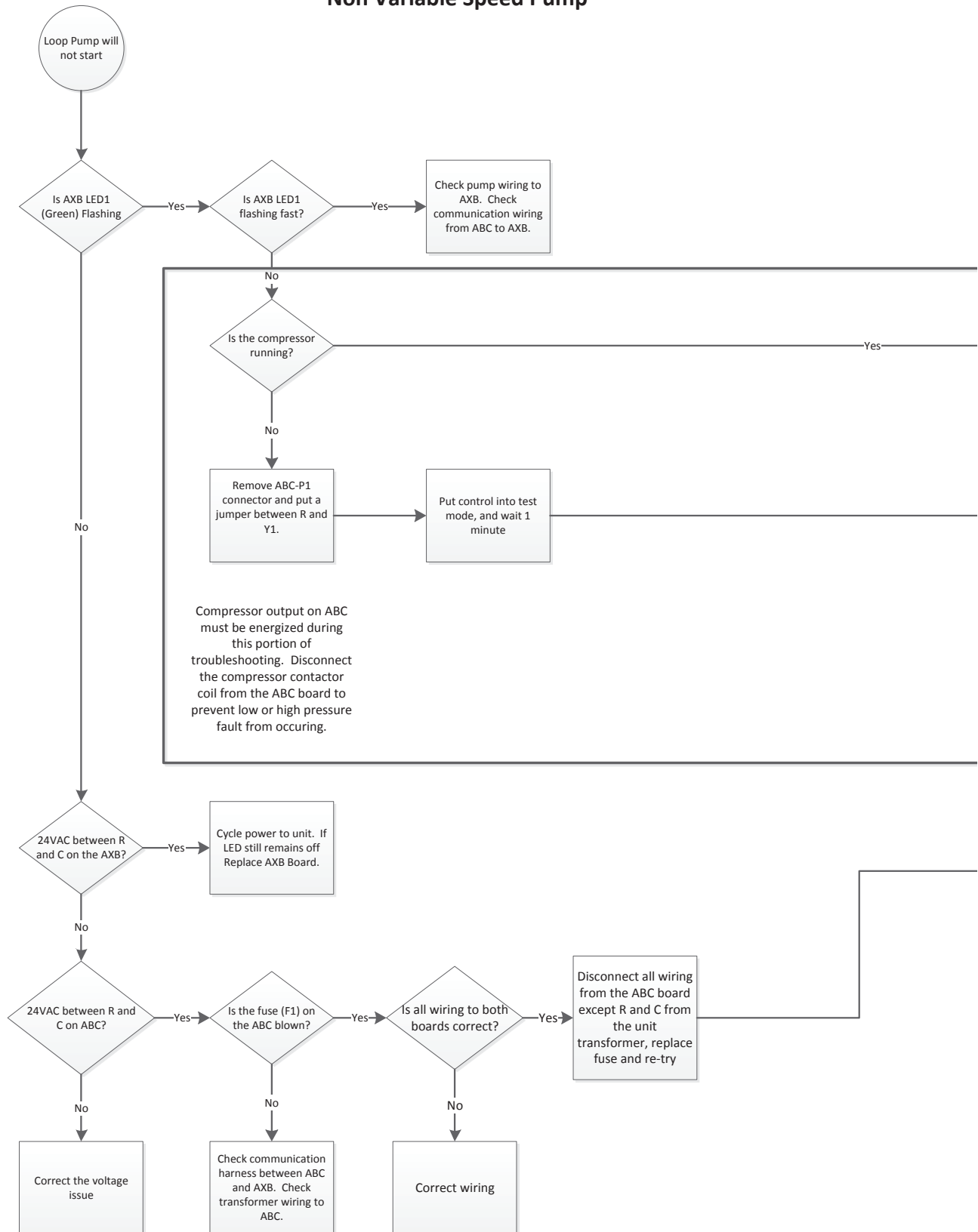

Control Board Troubleshooting Flow Charts cont.

Notes:

1. When measuring 24VAC actual value may be between 18 and 30VAC.
2. When measuring 240VAC actual value may be between 190 and 250 VAC.

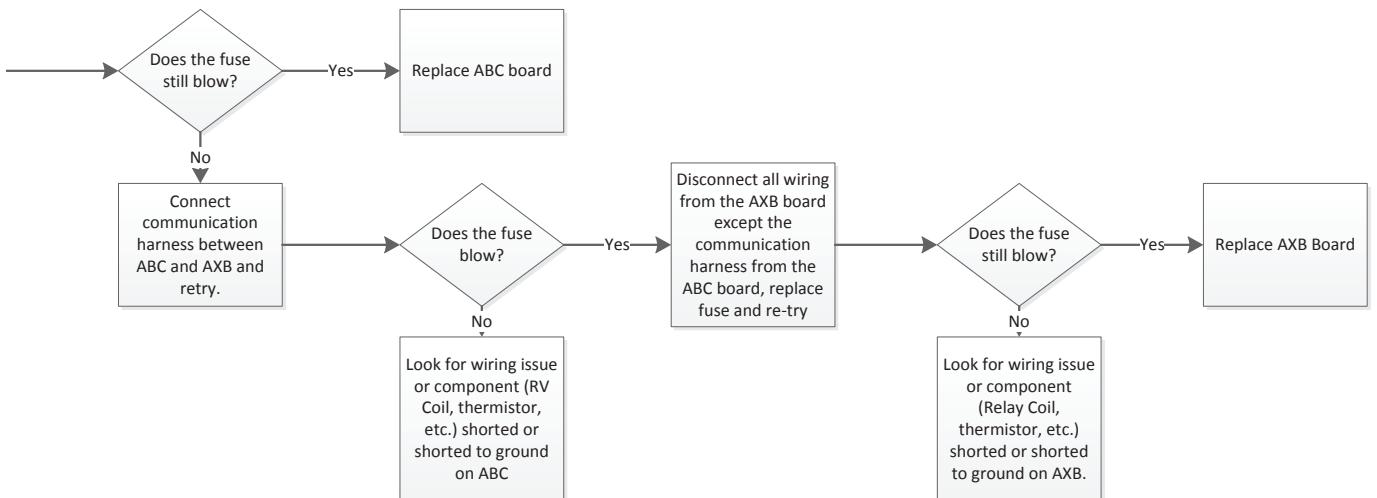
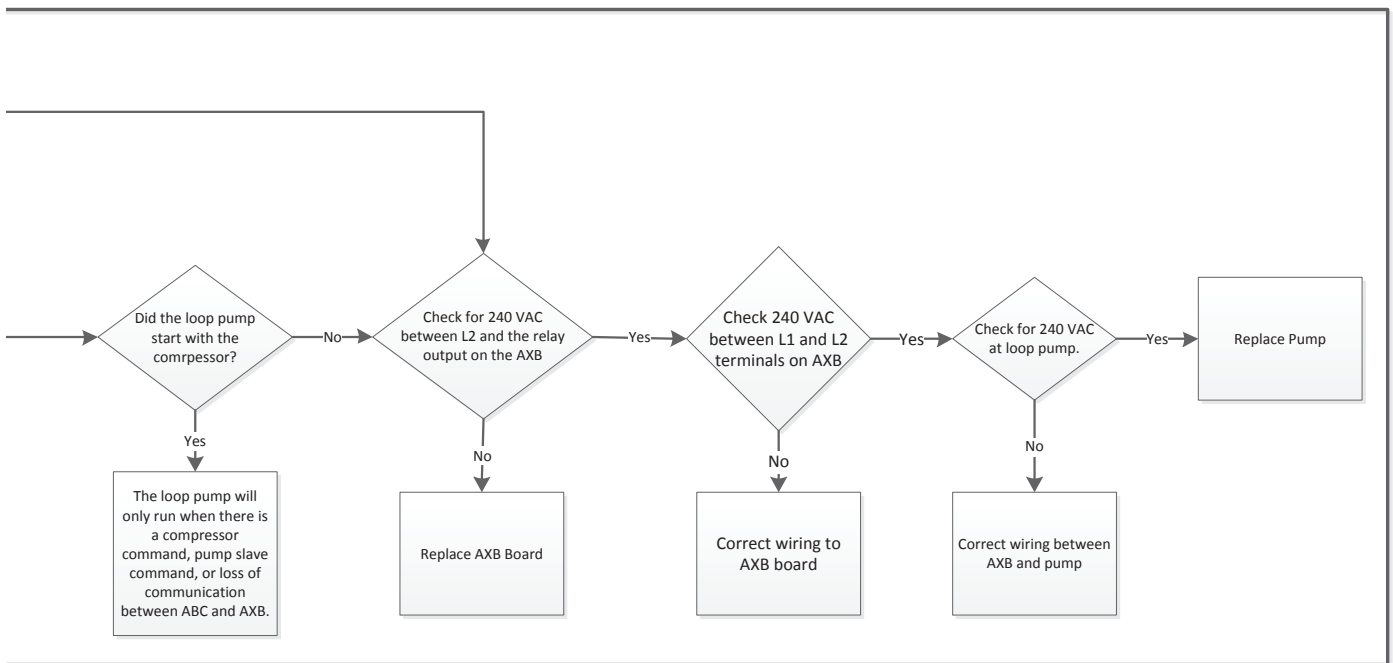

Communicating Thermostat Troubleshooting Guide

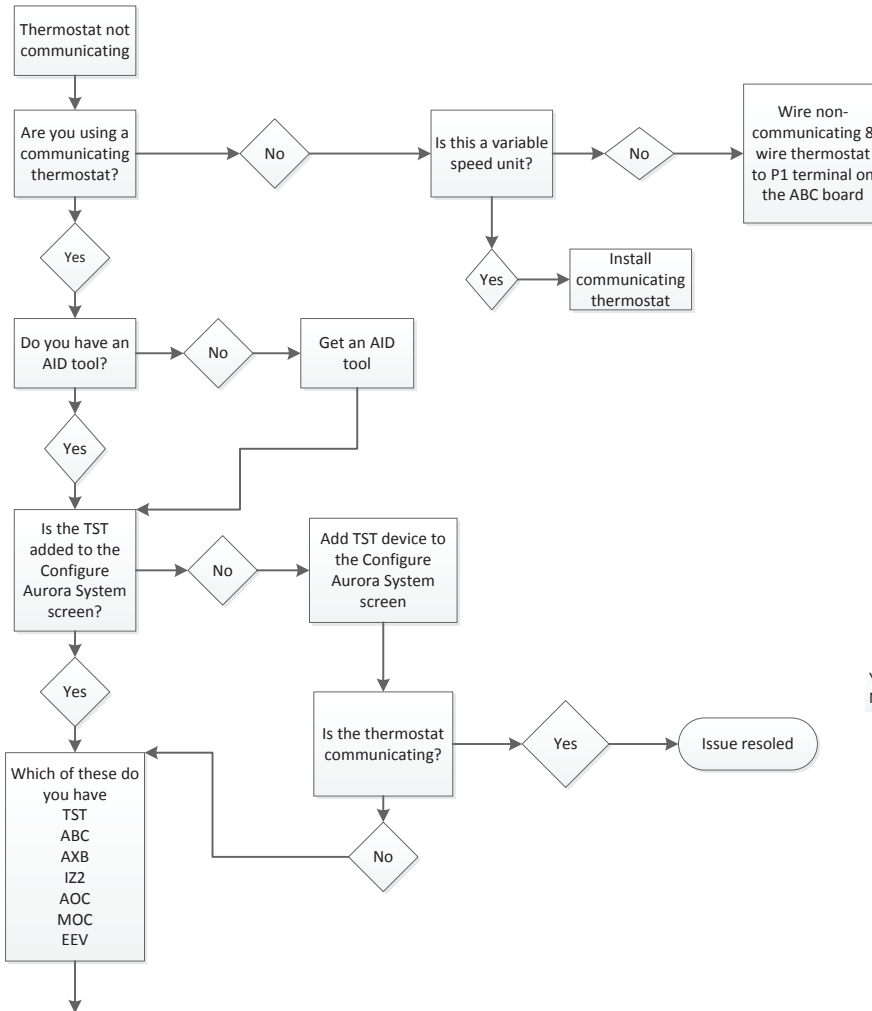

Configure Aurora System Screen

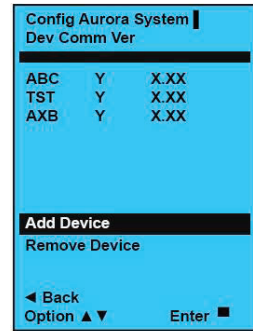

Single and Dual Capacity unit

Y – Active Communication
 N – Device has been found, but communication has failed.

Continue to Next Page

Communicating Thermostat Troubleshooting Guide cont.

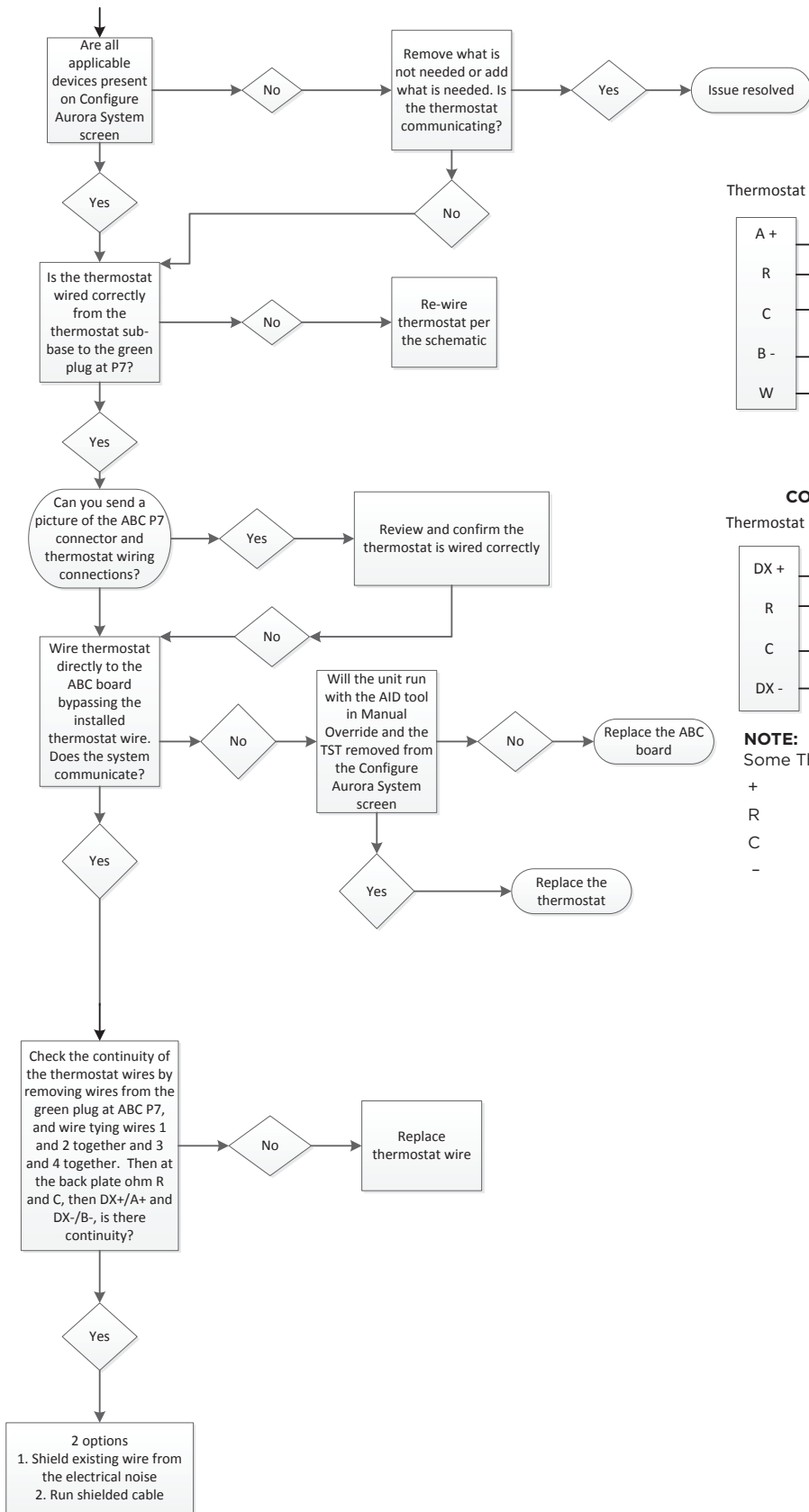

TPCM32U03A*/TPCM32U04A*

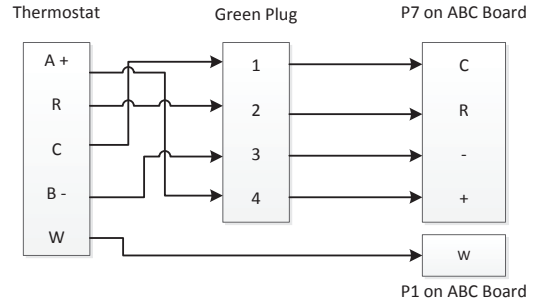

TPCC SERIES
COLOR TOUCHSCREEN THERMOSTAT

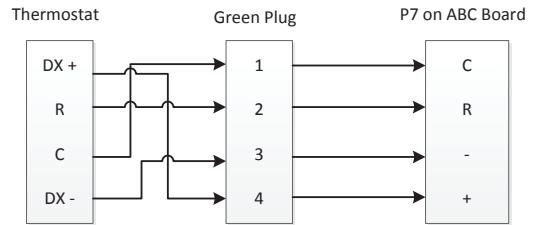

NOTE:
Some Thermostats will be:

- +
- R
- C
-

Control Board Signals

To Check for 24VAC between R and C

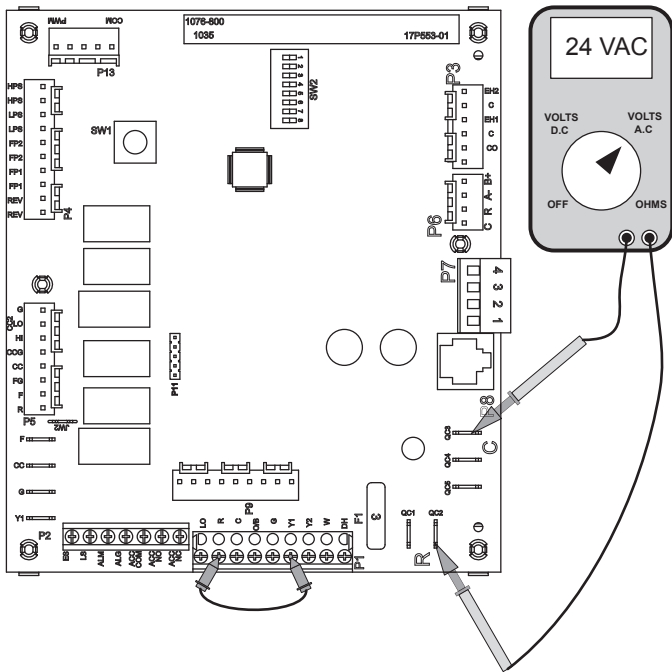

With power applied to the unit connect your Volt meter leads to “R” and “C” on the control board where the yellow and black/white transformer wires connect. The reading should be between 18VAC and 30VAC.

To Check for 24VAC to Compressor Contactor

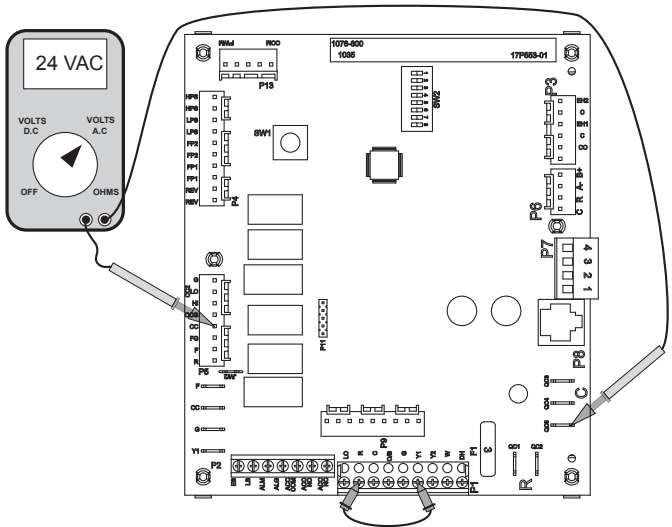

With the AID Tool go to the “Thermostat Inputs” Menu under “Diagnostics” and over-ride the “Y1” input to ON. If an AID Tool is not available remove the P1 connector to disconnect the thermostat from the board and place a jumper wire between “R” and “Y1” as shown. Apply power and put the board into test mode by holding SW1 for 2-5 seconds, the green LED will begin a slow flash. Connect your Volt meter leads to “CC” and “C”. After 1 minute the reading should be between 18 and 30VAC. If you have

a signal and the contactor is not pulled in, check voltage across the contactor coil. If you have voltage across the contractor coil, replace the contactor. If there is no voltage across the contactor coil, verify all wiring between the board and contactor. If you have no voltage between CC and C and the fault LED is not flashing, then replace the board.

To Check Operation of the Reversing Valve Output

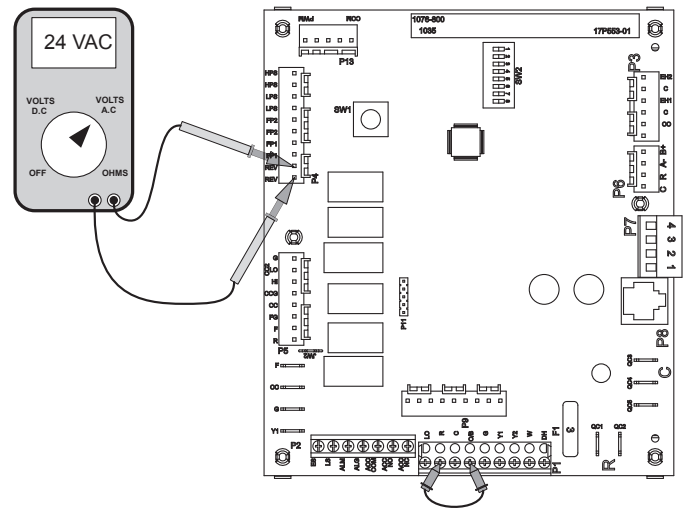

Control Board Signals cont.

To Check the Condensate Sensor

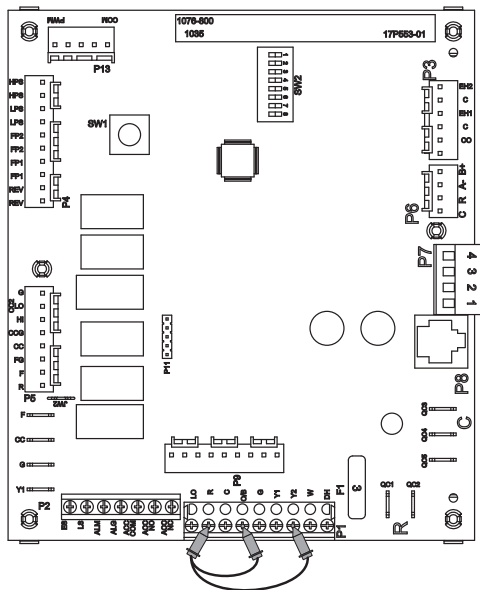

How it works: The condensate sensor is a three part system: a wire, air coil, and water in the drain pan. The wire (spade terminal) and air coil act like a normally open contact and the water acts as the switch. When water in the drain pan fills up and touches the spade terminal, the unit will fault on condensate.

Checking the Sensor: With the AID Tool go to the “Thermostat Inputs” Menu under “Diagnostics” and over-ride the “O” and “Y2” inputs to ON. If an AID Tool is not available remove the P1 connector to disconnect the thermostat from the board and place a jumper wire between “R”, “Y2”, and “O” as shown. Apply power and put the board into test mode by holding SW1 for 2-5 seconds, the green LED will begin a slow flash. Observe the water level in the drain pan. If the unit is locking out on condensate and the drain pan is dry, remove the condensate wire from the drain pan and tape it out of the way. Be careful not to ground the wire out because that will cause the unit to lockout on condensate over flow. If the unit is still locking out, check the brown wire all the way back to the logic board for a short to ground. Remember that the condensate sensor is just a wire looking for a ground. If it touches any metal in the cabinet, the unit will see that as a condensate fault.

If removing the wire from the drain pan stopped the false drain lockouts, put the condensate sensor back in place in the drain pan. Pay close attention to how far the spade terminal sits down in the drain pan. If the terminal is pushed all the way down so that it is touching the bottom of the drain pan, this will cause a condensate lockout if there is any trace of water in the drain pan. If the spade terminal fits loosely in the drain pan, spread the terminal open to make it fit snugly in the drain pan.

To Check the ECM Blower Motor Enable Signal

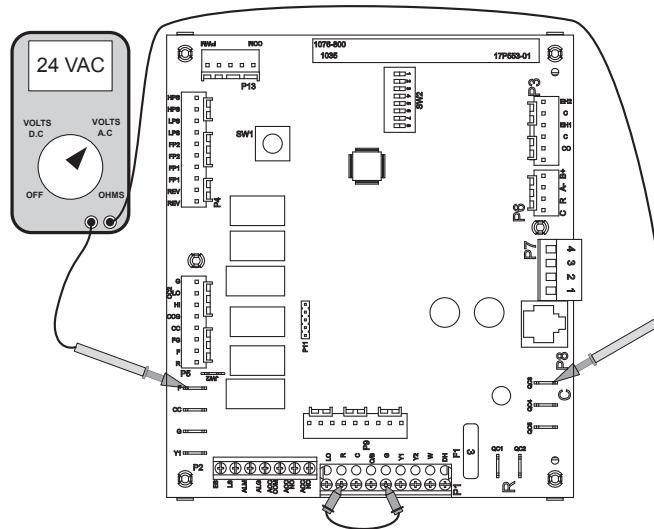

With the AID Tool go to the “Thermostat Inputs” Menu under “Diagnostics” and over-ride the “G” input to ON. If an AID Tool is not available remove the P1 connector to disconnect the thermostat from the board and place a jumper between “R” and “G” as shown. Put the board into test mode by holding SW1 for 2-5 seconds. The blower will come on and run in the “G” speed setting. To check the enable signal to the motor, measure 24VAC between the F and C terminals.

To Check the Electric Heat Outputs

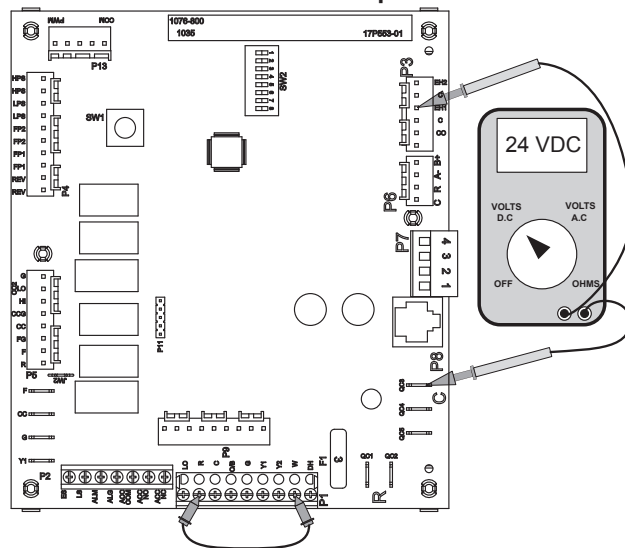

With the AID Tool go to the “Thermostat Inputs” Menu under “Diagnostics” and over-ride the “W” input to ON. If an AID Tool is not available remove the P1 connector to disconnect the thermostat from the board and place a jumper between “R” and “W” as shown. Put the board into test mode by holding SW1 for 2-5 seconds. The blower will come on and run in high speed. 10 seconds later electric heat output 1 (EH1) will be enabled followed by electric heat output 2 (EH2) in 7.5 seconds. Check EH1 by measuring DC volts between “C” and “EH1” and check EH2 by measuring DC volts between “C” and “EH2”.

Jumping the Control Board cont.

Emergency Heat

With the AID Tool go to the “Thermostat Inputs” Menu under “Diagnostics” and over-ride the “W” input to ON. If an AID Tool is not available remove the P1 connector to disconnect the thermostat from the board. Place a jumper between the “R” and “W” terminals as shown.

The blower will start on high speed and after 20 seconds the first stage of resistance heat is energized. Continuing demand will engage the second stage after 2 minutes.

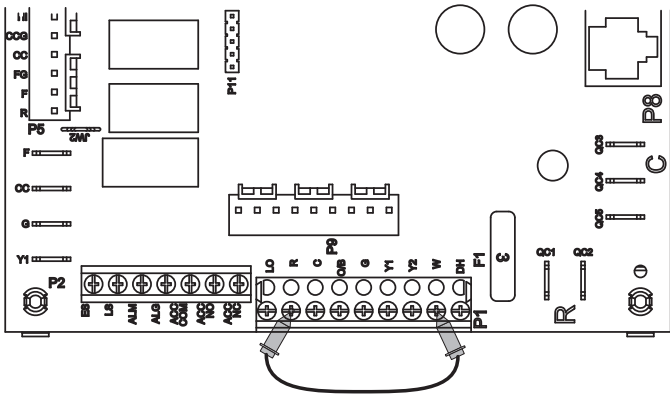

Blower Only

With the AID Tool go to the “Thermostat Inputs” Menu under “Diagnostics” and over-ride the “G” input to ON. If an AID Tool is not available remove the P1 connector to disconnect the thermostat from the board. Place a jumper between the “R” and “G” terminals as shown.

The blower will start on the “G” speed setting. Also, regardless of blower speed setting, the blower will remain on for 30 seconds at the end of each heating, cooling, emergency heat, or reheat cycle.

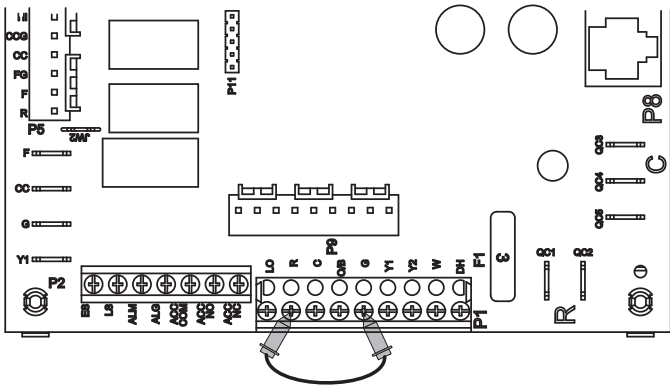

Stage 1 Cooling

With the AID Tool go to the “Thermostat Inputs” Menu under “Diagnostics” and over-ride the “Y1” and “O” inputs to ON. If an AID Tool is not available remove the P1 connector to disconnect the thermostat from the board. Place a jumper between the R, O, and Y1 terminals as shown.

The blower motor will start in “G” blower speed setting immediately, the compressor will start 10 seconds later. If the unit is equipped with an ECM blower motor it will switch to low speed 15 seconds after the Y1 input.

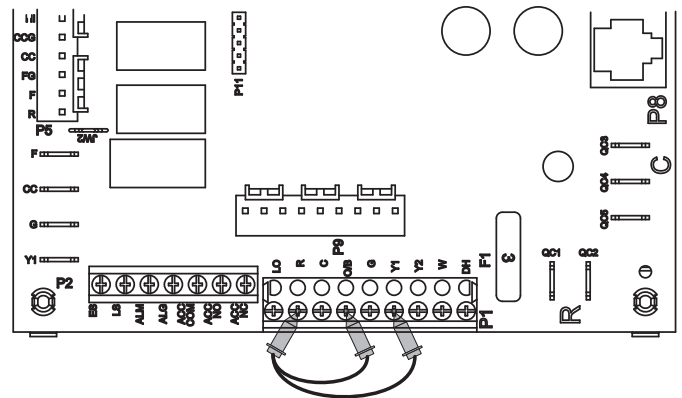

Stage 2 Cooling

With the AID Tool go to the “Thermostat Inputs” Menu under “Diagnostics” and over-ride the “Y1”, “Y2”, and “O” inputs to ON. If an AID Tool is not available remove the P1 connector to disconnect the thermostat from the board. Place a jumper between the R, O, Y1, and Y2 terminals as shown.

The blower motor will start in “G” blower speed setting immediately the compressor will start 10 seconds later. If the unit is equipped with an ECM blower motor it will switch to low speed 15 seconds after the Y1 input. The compressor will stage to full capacity 20 seconds after the compressor starts, and the blower will change to high speed.

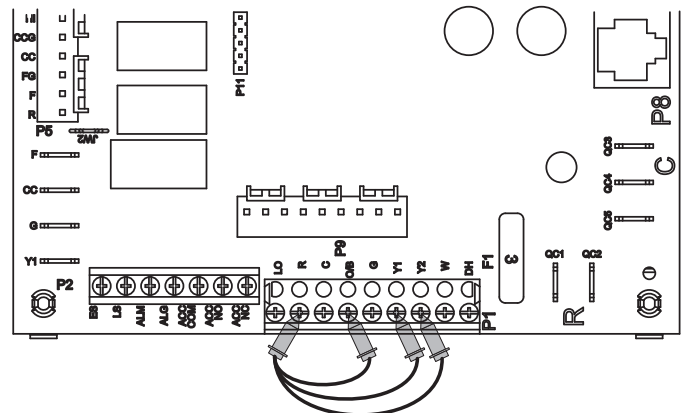

Jumping the Control Board cont.

Reheat Mode

With the AID Tool go to the “Thermostat Inputs” Menu under “Diagnostics” and over-ride the “DH” input to ON. If an AID Tool is not available remove the P1 connector to disconnect the thermostat from the board. Place a jumper between the R and DH terminals as shown.

The blower motor will start in “G” blower speed setting immediately the compressor will start 10 seconds later. If the unit is equipped with an ECM blower motor it will switch to low speed 15 seconds after the DH input. 20 seconds after the DH input is received the compressor will switch to full capacity and the blower motor will switch to dehumidification high speed. 30 seconds after the compressor starts the alarm/reheat output will energize.

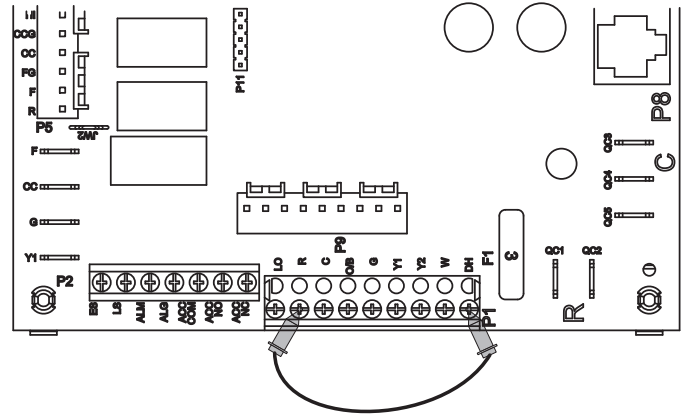

Troubleshooting

Sensor Locations

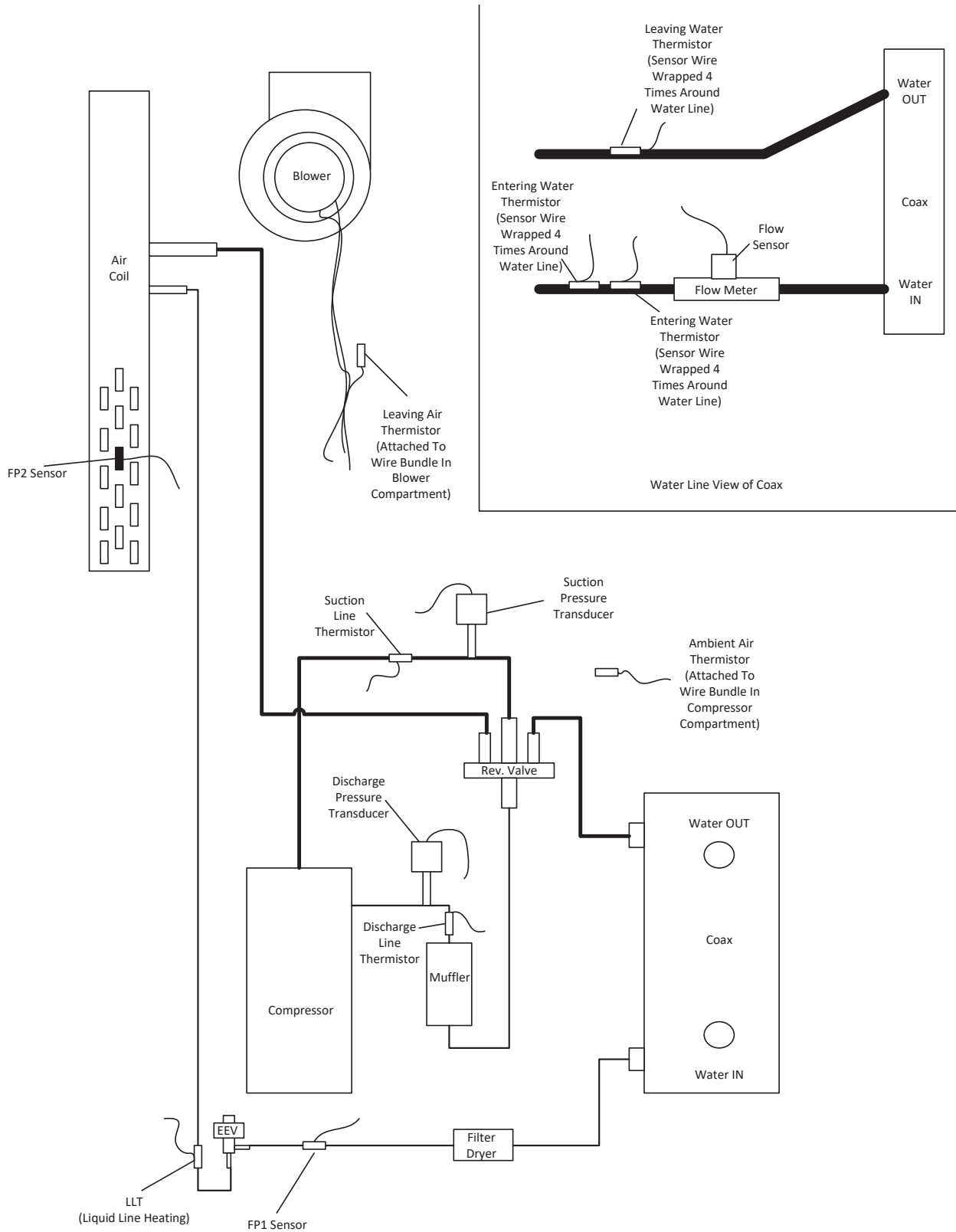

Troubleshooting

Variable Speed Startup/Troubleshooting Form

1. Job Information

Model # _____ Job Name: _____ Loop: Open / Closed
 Serial # _____ Install Date: _____ Hot Water Generator: Y / N

2. Flow Rate in gpm

SOURCE COAX

	HEATING SPEED 12	HEATING SPEED 4	COOLING SPEED 9	COOLING SPEED 3
WATER IN Pressure:	a. _____ psi	a. _____ psi	a. _____ psi	a. _____ psi
WATER OUT Pressure:	b. _____ psi	b. _____ psi	b. _____ psi	b. _____ psi
Pressure Drop: a - b	c. _____ psi	c. _____ psi	c. _____ psi	c. _____ psi
Look up flow rate in table:	d. _____ gpm	d. _____ gpm	d. _____ gpm	d. _____ gpm

3. Temperature Rise/Drop Across Coaxial Heat Exchanger¹

	HEATING SPEED 12	HEATING SPEED 4	COOLING SPEED 9	COOLING SPEED 3
WATER IN Temperature:	e. _____ °F	e. _____ °F	e. _____ °F	e. _____ °F
WATER OUT Temperature:	f. _____ °F	f. _____ °F	f. _____ °F	f. _____ °F
Temperature Difference:	g. _____ °F	g. _____ °F	g. _____ °F	g. _____ °F

4. Temperature Rise/Drop Across Air Coil

	HEATING SPEED 12	HEATING SPEED 4	COOLING SPEED 9	COOLING SPEED 3
SUPPLY AIR Temperature:	h. _____ °F	h. _____ °F	h. _____ °F	h. _____ °F
RETURN AIR Temperature:	i. _____ °F	i. _____ °F	i. _____ °F	i. _____ °F
Temperature Difference:	j. _____ °F	j. _____ °F	j. _____ °F	j. _____ °F

5. Heat of Rejection (HR)/Heat of Extraction (HE)

Brine Factor²: k. _____

	HEATING SPEED 12	HEATING SPEED 4	COOLING SPEED 9	COOLING SPEED 3
HR/HE = d x g x k	l. _____ Btu/h	l. _____ Btu/h	l. _____ Btu/h	l. _____ Btu/h

STEPS 6-9 NEED ONLY BE COMPLETED IF A PROBLEM IS SUSPECTED. USE HEATING SPEED 12 AND COOLING SPEED 9 FOR STEPS 6-9.

6. Watts

ENERGY MONITOR

	HEATING SPEED 12	COOLING SPEED 9
Volts:	m. _____ Volts	m. _____ Volts
Total Amps (Comp. + Blower) ³ :	n. _____ Amps	n. _____ Amps
Watts = m x n x 0.85:	o. _____ Watts	o. _____ Watts

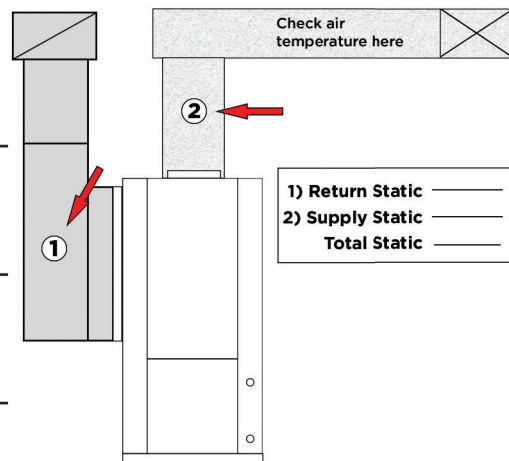

7. Capacity

	HEATING SPEED 12	COOLING SPEED 9
Cooling Capacity = l - (o x 3.413):	p. _____ Btu/h	p. _____ Btu/h
Heating Capacity = l + (o x 3.413):		

8. Efficiency

	HEATING SPEED 12	COOLING SPEED 9
Cooling EER = p / o:	q. _____ Btu/h	q. _____ Btu/h
Heating COP = p / (o x 3.413):		

9. Superheat (S.H.)/Subcooling (S.C.)

	HEATING SPEED 12	COOLING SPEED 9
Suction Pressure:	r. _____ psi	r. _____ psi
Suction Saturation Temperature:	s. _____ °F	s. _____ °F
Suction Line Temperature:	t. _____ °F	t. _____ °F
S.H. = t - s	u. _____ °F	u. _____ °F
Head Pressure:	v. _____ psi	v. _____ psi
High Pressure Saturation Temp:	w. _____ °F	w. _____ °F
Liquid Line Temperature ⁴ :	x. _____ °F	x. _____ °F
S.C. = w - x	y. _____ °F	y. _____ °F

Software Version	
ABC:	_____
AXB:	_____
IZ2:	_____
TSTAT:	_____

- NOTES:**
- Steps 3-9 should be conducted with the hot water generator disconnected.
 - Use 500 for pure water, 485 for methanol or Enviranol™. (This constant is derived by multiplying the weight of one gallon of water (8.34) times the minutes in one hour (60) times the specific heat of the fluid. Water has a specific heat of 1.0.)
 - If there is only one source of power for the compressor and blower, amp draw can be measured at the source wiring connection.
 - Liquid line is between the coax and the expansion device in the cooling mode; between the air coil and the expansion device in the heating mode.

Performance Data

024 - 50% Part Load

EWT °F	Flow gpm	WPD		HEATING - EAT 70°F							EWT °F	Flow gpm	WPD		COOLING - EAT 80/67 °F									
		PSI	FT	Airflow cfm	HC MBtuh	Power kW	HE MBtuh	LAT °F	COP	HWC MBtuh			PSI	FT	Airflow cfm	TC MBtuh	SC MBtuh	S/T Ratio	Power kW	HR MBtuh	EER	HWC MBtuh		
20	3.0	0.37	0.8	Operation not recommended							20	2.5	0.19	0.4	Operation not recommended									
	4.5	0.84	1.9	Operation not recommended								3.5	0.58	1.3	Operation not recommended									
	5.5	1.31	3.0	600	7.6	0.72	4.7	78.6	3.13	1.3		800	7.7	0.63	5.1	73.8	3.57	1.1						
30	3.0	0.35	0.8	600	8.0	0.60	5.5	79.4	3.92	1.4	30	2.5	0.18	0.4	500	13.7	10.0	0.73	0.40	14.2	34.5	-		
				800	8.3	0.61	5.8	74.9	3.97	1.2					650	14.0	11.0	0.79	0.41	14.5	33.8	-		
	4.5	0.81	1.9	600	8.2	0.60	5.7	79.9	4.00	1.5		3.5	0.56	1.3	500	13.9	10.1	0.73	0.38	14.3	36.8	-		
				800	8.5	0.61	6.0	75.3	4.06	1.3					650	14.1	11.0	0.78	0.40	14.6	35.5	-		
	5.5	1.27	2.9	600	9.0	0.72	6.1	81.9	3.69	1.6		5.0	0.94	2.2	500	14.0	10.1	0.72	0.37	14.3	38.1	-		
				800	9.1	0.63	6.5	76.2	4.21	1.3					650	14.3	11.0	0.77	0.39	14.7	37.2	-		
40	3.0	0.34	0.8	600	9.3	0.60	6.9	82.7	4.53	1.5	40	2.5	0.18	0.4	500	15.3	10.6	0.70	0.36	15.5	42.5	-		
				800	9.7	0.62	7.1	77.3	4.60	1.3					650	15.6	11.6	0.75	0.37	15.8	41.6	-		
	4.5	0.79	1.8	600	9.6	0.61	7.2	83.4	4.66	1.7		3.5	0.54	1.3	500	15.5	10.7	0.69	0.34	15.6	45.3	-		
				800	10.0	0.62	7.4	77.8	4.73	1.4					650	15.8	11.7	0.74	0.36	15.9	44.0	-		
	5.5	1.23	2.8	600	10.2	0.62	7.6	84.7	4.79	1.7		5.0	0.91	2.1	500	15.6	10.7	0.69	0.33	15.7	47.0	-		
				800	10.5	0.63	7.9	78.8	4.87	1.4					650	15.9	11.7	0.74	0.35	16.1	46.0	-		
50	3.0	0.33	0.8	600	10.7	0.61	8.2	86.0	5.12	1.7	50	2.5	0.17	0.4	500	16.6	10.9	0.65	0.31	16.6	53.2	-		
				800	11.0	0.62	8.5	79.7	5.21	1.4					650	17.1	12.0	0.70	0.32	17.1	53.6	-		
	4.5	0.76	1.8	600	11.1	0.61	8.6	86.9	5.29	1.8		3.5	0.53	1.2	500	16.8	10.9	0.65	0.30	16.7	55.1	-		
				800	11.4	0.62	8.9	80.4	5.39	1.5					650	17.3	12.1	0.70	0.31	17.2	55.6	-		
	5.5	1.19	2.8	600	11.6	0.63	9.0	88.2	5.42	1.9		5.0	0.88	2.0	500	17.1	11.2	0.66	0.30	17.0	56.5	-		
				800	11.9	0.64	9.3	81.3	5.51	1.7					650	17.6	12.4	0.71	0.31	17.4	57.0	-		
60	3.0	0.32	0.7	600	12.1	0.62	9.6	89.5	5.72	1.8	60	2.5	0.17	0.4	500	15.0	10.7	0.71	0.41	15.4	36.4	0.7		
				800	12.4	0.63	9.9	82.2	5.82	1.5					650	15.4	11.9	0.77	0.42	15.8	36.7	0.8		
	4.5	0.74	1.7	600	12.6	0.62	10.1	90.6	5.96	1.9		3.5	0.51	1.2	500	15.1	10.8	0.71	0.40	15.5	37.7	0.8		
				800	12.9	0.62	10.4	83.0	6.06	1.6					650	15.6	11.9	0.77	0.41	15.9	38.0	0.8		
	5.5	1.15	2.7	600	13.1	0.63	10.5	91.7	6.03	2.0		5.0	0.85	2.0	500	15.4	11.1	0.72	0.40	15.7	38.7	0.9		
				800	13.4	0.64	10.7	83.8	6.14	1.7					650	15.8	12.2	0.77	0.41	16.2	39.0	0.9		
70	3.0	0.31	0.7	600	13.5	0.63	11.0	92.9	6.30	1.9	70	2.5	0.16	0.4	500	13.4	10.6	0.79	0.51	14.2	26.1	0.9		
				800	13.7	0.64	11.1	84.5	6.34	1.6					650	14.0	11.9	0.85	0.60	15.1	23.2	1.0		
	4.5	0.71	1.7	600	14.1	0.63	11.6	94.3	6.60	2.0		3.5	0.49	1.1	500	13.5	10.6	0.79	0.50	14.3	27.1	1.1		
				800	14.4	0.63	11.8	85.7	6.73	1.7					650	13.9	11.8	0.85	0.51	14.7	27.3	1.1		
	5.5	1.12	2.6	600	14.5	0.64	11.9	95.2	6.63	2.1		5.0	0.83	1.9	500	13.7	10.9	0.80	0.49	14.5	27.7	1.1		
				800	14.8	0.64	12.1	86.3	6.76	1.8					650	13.7	11.9	0.87	0.44	15.3	31.1	1.1		
80	3.0	0.30	0.7	600	14.9	0.64	12.3	96.1	6.80	2.0	80	2.5	0.16	0.4	500	12.5	9.8	0.78	0.63	13.8	19.9	1.5		
				800	15.1	0.64	12.5	86.9	6.93	1.7					650	12.9	10.9	0.84	0.64	14.2	20.1	1.5		
	4.5	0.69	1.6	600	15.6	0.64	13.0	97.9	7.17	2.2		3.5	0.48	1.1	500	12.6	9.9	0.78	0.61	13.9	20.6	1.6		
				800	15.8	0.63	13.2	88.1	7.31	1.8					650	13.0	10.9	0.84	0.63	14.3	20.8	1.6		
	5.5	1.08	2.5	600	15.8	0.65	13.2	98.4	7.13	2.3		5.0	0.80	1.8	500	12.8	10.1	0.79	0.61	14.1	21.1	1.6		
				800	16.0	0.65	13.3	88.5	7.27	1.9					650	13.2	11.2	0.85	0.62	14.4	21.3	1.9		
90	3.0	0.29	0.7	600	16.2	0.65	13.6	99.4	7.28	2.2	90	2.5	0.15	0.3	500	11.7	9.0	0.77	0.75	13.4	15.6	1.9		
				800	16.4	0.65	13.7	89.2	7.43	1.8					650	12.0	10.0	0.83	0.76	13.8	15.8	1.9		
	4.5	0.67	1.5	600	17.1	0.65	14.4	101.4	7.72	2.3		3.5	0.46	1.1	500	11.8	9.1	0.77	0.73	13.5	16.2	2.0		
				800	17.2	0.64	14.6	90.6	7.88	1.9					650	12.1	10.1	0.83	0.74	13.8	16.3	2.0		
	5.5	1.04	2.4	600	17.1	0.66	14.4	101.6	7.61	2.5		5.0	0.78	1.8	500	12.5	9.6	0.77	0.74	14.2	16.9	2.1		
				800	17.2	0.65	14.6	90.7	7.76	2.0					650	11.8	10.9	0.92	0.74	14.6	15.9	2.1		
100	3.0	0.28	0.6	Operation not recommended							100	2.5	0.15	0.3	500	10.9	8.7	0.80	0.90	13.2	12.1	2.3		
	4.5	0.64	1.5	Operation not recommended								3.5	0.44	1.0	500	11.0	8.7	0.80	0.88	13.3	12.5	2.4		
	5.5	1.00	2.3	Operation not recommended								5.0	0.74	1.7	500	11.2	9.0	0.80	0.87	13.4	12.8	2.5		
110	3.0	0.27	0.6	Operation not recommended							110	2.5	0.14	0.3	500	10.1	8.3	0.83	1.06	13.0	9.5	2.2		
				650	10.4	9.2	0.89	1.08	13.4	9.6					2.3									
	4.5	0.62	1.4	Operation not recommended								3.5	0.43	1.0	500	10.2	8.4	0.82	1.03	13.0	9.9	2.4		
				650	10.5	9.3	0.89	1.05	13.4	10.0					2.4									
	5.5	0.96	2.2	Operation not recommended								5.0	0.71	1.6	500	10.4	8.6	0.83	1.02	13.2	10.1	2.6		
				650	10.7	9.5	0.89	1.04	13.5	10.2					2.6									
120	3.0	0.26	0.6	Operation not recommended							120	2.5	0.13	0.3	500	9.4	8.5	0.90	1.35	13.4	7.0	3.2		
				650	9.6	9.2	0.96	1.38	13.7	7.0					3.3									
	4.5	0.59	1.4	Operation not recommended								3.5	0.41	0.9	500	9.5	8.5	0.90	1.28	13.3	7.5	3.3		
				650	9.7	9.3	0.96	1.31	13.5	7.4					3.3									
	5.5	0.93	2.1	Operation not recommended								5.0	0.68	1.6	500	9.6	8.5	0.89	1.24	13.2	7.8	3.4		
				650	9.8	9.4	0.96	1.15	12.0	8.5					3.4									

Performance capacities shown in thousands of Btuh.

Performance Data

024 - 100% Full Load

EWT °F	Flow gpm	WPD		HEATING - EAT 70°F							EWT °F	Flow gpm	WPD		COOLING - EAT 80/67 °F							
		PSI	FT	Airflow cfm	HC MBtuh	Power kW	HE MBtuh	LAT °F	COP	HWC MBtuh			PSI	FT	Airflow cfm	TC MBtuh	SC MBtuh	S/T Ratio	Power kW	HR MBtuh	EER	HWC MBtuh
20	5.0	0.87	2.0	Operation not recommended							20	4.0	0.49	1.1	Operation not recommended							
	7.0	2.15	5.0	Operation not recommended								6.0	1.70	3.9	Operation not recommended							
	9.0	2.81	6.5	1000	22.4	2.11	14.2	90.7	3.12	3.8		1350	23.1	2.04	15.2	86.1	3.33	3.4				
30	5.0	0.85	2.0	1000	25.1	1.94	17.6	93.4	3.80	4.1	30	4.0	0.48	1.1	700	24.5	16.7	0.68	0.48	26.8	51.0	-
				1350	25.9	2.01	18.0	88.2	3.77	3.8					850	24.9	18.3	0.73	0.50	27.3	49.8	-
	7.0	2.09	4.8	1000	25.8	1.97	18.1	94.0	3.83	4.2		700	24.8	16.8	0.68	0.46	27.0	54.3	-			
				1350	26.5	2.03	18.6	88.6	3.83	3.9		850	25.2	18.4	0.73	0.48	27.5	52.4	-			
	9.0	2.36	5.5	1000	26.2	2.12	18.0	94.5	3.63	4.4		700	24.9	16.8	0.68	0.44	27.1	56.3	-			
				1350	25.2	1.90	18.8	89.3	3.89	5.0		850	25.6	18.4	0.72	0.47	27.8	54.9	-			
40	5.0	0.82	1.9	1000	29.0	1.97	21.3	97.2	4.31	4.5	40	4.0	0.46	1.1	700	25.9	18.0	0.70	0.58	28.6	45.0	-
				1350	29.9	2.02	22.0	91.2	4.33	4.0					850	26.4	19.7	0.75	0.60	29.3	44.0	-
	7.0	2.03	4.7	1000	30.0	2.01	22.1	98.1	4.36	4.6		700	26.2	18.2	0.69	0.55	28.8	47.9	-			
				1350	30.9	2.06	22.9	91.9	4.40	4.1		850	26.7	19.8	0.74	0.57	29.4	46.5	-			
	9.0	2.65	6.1	1000	30.5	2.03	22.6	98.7	4.41	4.8		700	26.4	18.2	0.69	0.53	28.9	49.7	-			
				1350	31.5	2.08	23.4	92.4	4.45	4.2		850	27.0	19.8	0.74	0.56	29.6	48.6	-			
50	5.0	0.79	1.8	1000	32.9	2.01	25.1	101.1	4.81	4.8	50	4.0	0.45	1.0	700	26.2	17.7	0.68	0.67	29.4	39.2	-
				1350	33.9	2.04	26.0	94.3	4.88	4.5					850	27.5	19.7	0.72	0.70	30.9	39.2	-
	7.0	1.97	4.5	1000	34.1	2.05	26.1	102.3	4.87	5.2		700	26.7	17.9	0.67	0.63	29.7	42.5	-			
				1350	35.2	2.08	27.1	95.2	4.96	4.6		850	28.1	19.9	0.71	0.66	31.3	42.6	-			
	9.0	2.56	5.9	1000	34.9	2.07	26.8	103.0	4.94	5.3		700	27.0	19.2	0.71	0.61	29.9	43.9	-			
				1350	36.0	2.10	27.8	95.8	5.02	5.4		850	28.3	20.8	0.73	0.60	30.5	47.2	-			
60	5.0	0.74	1.7	1000	36.2	2.02	28.3	104.3	5.24	4.9	60	4.0	0.45	1.0	700	25.1	17.8	0.71	0.92	28.8	27.3	1.3
				1350	37.3	2.04	29.4	96.8	5.38	4.5					850	26.4	19.8	0.75	0.96	30.2	27.4	1.4
	7.0	1.90	4.4	1000	37.8	2.08	29.7	105.9	5.33	5.4		700	25.7	18.0	0.70	0.87	29.2	29.4	1.4			
				1350	39.0	2.09	30.9	98.1	5.47	4.6		850	27.0	20.0	0.74	0.91	30.6	29.6	1.5			
	9.0	2.48	5.7	1000	38.7	2.10	30.5	106.8	5.40	5.5		700	26.0	19.0	0.73	0.85	29.4	30.5	1.4			
				1350	40.0	2.11	31.8	98.8	5.55	4.8		850	27.3	21.1	0.77	0.89	30.8	30.6	1.5			
70	5.0	0.72	1.7	1000	39.5	2.04	31.5	107.5	5.68	5.3	70	4.0	0.44	1.0	700	24.1	17.9	0.74	1.15	28.7	20.9	1.9
				1350	40.8	2.11	32.6	99.5	5.66	5.0					850	25.6	20.7	0.81	1.15	30.1	22.3	2.0
	7.0	1.84	4.3	1000	41.5	2.10	33.3	109.5	5.78	5.5		700	24.7	18.1	0.73	0.99	28.7	24.9	2.2			
				1350	42.8	2.10	34.6	101.0	5.97	5.1		850	25.8	20.1	0.78	1.03	29.9	25.1	2.2			
	9.0	1.94	4.5	1000	42.5	2.13	34.2	110.6	5.86	6.1		700	25.0	18.8	0.75	0.97	28.8	25.8	2.2			
				1350	42.0	2.12	34.7	100.4	5.81	6.6		850	26.3	19.8	0.75	0.98	28.9	26.8	2.3			
80	5.0	0.70	1.6	1000	42.2	2.07	34.1	110.2	5.96	5.8	80	4.0	0.43	1.0	700	23.0	17.7	0.77	1.40	27.8	16.5	2.8
				1350	43.7	2.06	35.6	101.6	6.22	4.9					850	23.9	19.7	0.82	1.44	28.9	16.6	2.8
	7.0	1.78	4.1	1000	44.6	2.16	36.2	112.6	6.06	6.0		700	23.6	17.9	0.76	1.35	28.3	17.5	2.9			
				1350	46.1	2.14	37.8	103.5	6.33	5.1		850	24.6	19.9	0.81	1.39	29.3	17.7	2.9			
	9.0	2.32	5.4	1000	45.9	2.19	37.4	113.9	6.16	6.1		700	23.9	18.4	0.77	1.32	28.4	18.1	3.1			
				1350	47.5	2.15	39.1	104.5	6.46	5.7		850	24.9	20.4	0.82	1.36	29.5	18.3	3.1			
90	5.0	0.67	1.6	1000	44.9	2.11	36.7	112.9	6.23	5.9	90	4.0	0.42	1.0	700	21.9	17.6	0.80	1.59	27.3	13.8	3.7
				1350	46.5	2.08	38.4	103.8	6.55	5.4					850	22.7	19.5	0.86	1.62	28.2	14.0	3.7
	7.0	1.71	4.0	1000	47.8	2.21	39.1	115.7	6.34	6.2		700	22.6	17.8	0.79	1.54	27.8	14.6	3.9			
				1350	49.5	2.17	41.0	106.0	6.68	5.7		850	23.4	19.7	0.84	1.58	28.8	14.8	3.9			
	9.0	1.79	4.1	1000	49.3	2.24	40.5	117.2	6.45	6.9		700	23.0	17.4	0.76	1.52	28.1	15.1	4.1			
				1350	51.4	2.29	43.6	109.9	6.58	7.9		850	23.9	18.9	0.79	1.47	27.6	16.3	3.9			
100	5.0	0.64	1.5	Operation not recommended							100	4.0	0.42	1.0	700	20.4	16.9	0.83	1.84	26.6	11.1	4.7
	7.0	1.65	3.8	Operation not recommended								6.0	1.03	2.4	700	21.1	17.1	0.81	1.80	27.2	11.7	5.0
	9.0	2.16	5.0	Operation not recommended								8.0	1.70	3.9	700	21.3	17.1	0.80	1.77	27.3	12.0	5.2
110	5.0	0.62	1.4	Operation not recommended							110	4.0	0.40	0.9	700	21.5	16.3	0.76	2.09	26.0	10.3	5.7
	7.0	1.59	3.7	Operation not recommended								6.0	0.99	2.3	700	22.4	16.5	0.74	2.07	26.6	10.8	5.9
	9.0	2.07	4.8	Operation not recommended								8.0	1.64	3.8	700	22.6	16.2	0.72	2.03	26.7	11.1	6.2
120	5.0	0.58	1.3	Operation not recommended							120	4.0	0.39	0.9	700	19.1	15.9	0.83	2.48	25.2	7.7	6.9
	7.0	1.53	3.5	Operation not recommended								6.0	0.95	2.2	700	19.5	17.4	0.89	2.54	25.7	7.7	7.1
	9.0	1.99	4.6	Operation not recommended								8.0	1.56	3.6	700	19.3	16.1	0.83	2.34	24.9	8.3	7.2

Performance capacities shown in thousands of Btuh.

Performance Data

036 - 50% Part Load

EWT °F	Flow gpm	WPD		HEATING - EAT 70°F							EWT °F	Flow gpm	WPD		COOLING - EAT 80/67 °F									
		PSI	FT	Airflow cfm	HC MBtuh	Power kW	HE MBtuh	LAT °F	COP	HWC MBtuh			PSI	FT	Airflow cfm	TC MBtuh	SC MBtuh	S/T Ratio	Power kW	HR MBtuh	EER	HWC MBtuh		
20	3.0	0.30	0.7	Operation not recommended							20	2.5	0.15	0.4	Operation not recommended									
	4.5	0.70	1.6	Operation not recommended								3.5	0.46	1.1	Operation not recommended									
	5.5	1.09	2.5	550	12.7	1.36	7.8	91.4	2.74	2.2		750	12.8	1.20	8.5	85.8	3.13	1.8						
30	3.0	0.30	0.7	550	13.3	1.13	9.2	92.3	3.44	2.3	30	2.5	0.15	0.3	500	18.3	12.5	0.68	0.57	20.2	32.2	-		
				750	13.8	1.16	9.7	87.1	3.49	2.0					650	18.6	13.7	0.74	0.59	20.7	31.5	-		
	4.5	0.68	1.6	550	13.6	1.14	9.5	92.9	3.51	2.6	3.5	0.45	1.0	500	18.5	12.6	0.68	0.54	20.4	34.3	-			
				750	14.2	1.17	10.0	87.5	3.56	2.2				650	18.8	13.8	0.73	0.57	20.8	33.1	-			
	5.5	1.06	2.4	550	15.0	1.36	10.1	95.3	3.24	2.7	5.0	0.75	1.7	500	18.6	12.6	0.68	0.52	20.4	35.6	-			
				750	15.1	1.09	10.8	88.6	4.05	2.2				650	19.1	13.8	0.72	0.55	21.0	34.7	-			
40	3.0	0.29	0.7	550	15.6	1.15	11.4	96.2	3.97	2.5	40	2.5	0.14	0.3	500	20.4	13.3	0.65	0.51	22.1	39.7	-		
				750	16.1	1.17	11.9	89.9	4.03	2.2					650	20.8	14.5	0.70	0.53	22.6	38.9	-		
	4.5	0.66	1.5	550	16.1	1.15	11.9	97.0	4.09	2.8	3.5	0.44	1.0	500	20.6	13.4	0.65	0.49	22.3	42.3	-			
				750	16.6	1.17	12.4	90.5	4.15	2.3				650	21.0	14.7	0.70	0.51	22.8	41.1	-			
	5.5	1.02	2.4	550	16.9	1.18	12.7	98.5	4.20	2.8	5.0	0.73	1.7	500	20.8	13.4	0.65	0.47	22.4	43.9	-			
				750	17.5	1.20	13.2	91.6	4.27	2.4				650	21.3	14.7	0.69	0.50	22.9	42.9	-			
50	3.0	0.28	0.6	550	17.8	1.16	13.7	100.0	4.49	2.8	50	2.5	0.14	0.3	500	22.2	13.6	0.61	0.45	23.7	49.7	-		
				750	18.4	1.18	14.2	92.7	4.57	2.3					650	22.8	15.0	0.66	0.46	24.4	50.1	-		
	4.5	0.64	1.5	550	18.5	1.17	14.3	101.1	4.64	3.0	3.5	0.42	1.0	500	22.4	13.7	0.61	0.44	23.9	51.4	-			
				750	19.0	1.18	14.8	93.5	4.73	2.5				650	23.0	15.1	0.66	0.44	24.5	51.9	-			
	5.5	0.99	2.3	550	19.3	1.19	15.0	102.5	4.75	3.1	5.0	0.70	1.6	500	22.8	14.0	0.62	0.43	24.2	52.7	-			
				750	19.9	1.21	15.6	94.6	4.83	2.8				650	23.4	15.5	0.66	0.44	24.9	53.2	-			
60	3.0	0.27	0.6	550	20.2	1.18	16.0	104.0	5.02	3.0	60	2.5	0.13	0.3	500	20.0	13.4	0.67	0.59	22.0	34.0	1.0		
				750	20.7	1.19	16.4	95.6	5.10	2.5					650	20.6	14.8	0.72	0.60	22.6	34.3	1.0		
	4.5	0.62	1.4	550	21.0	1.18	16.8	105.4	5.23	3.2	3.5	0.41	0.9	500	20.2	13.5	0.67	0.57	22.2	35.2	1.1			
				750	21.5	1.19	17.3	96.6	5.32	2.7				650	20.8	14.9	0.72	0.59	22.8	35.5	1.1			
	5.5	0.96	2.2	550	21.8	1.21	17.4	106.6	5.29	3.3	5.0	0.68	1.6	500	20.5	13.8	0.67	0.57	22.5	36.1	1.2			
				750	22.3	1.21	17.9	97.5	5.38	2.8				650	21.1	15.3	0.73	0.58	23.1	36.4	1.2			
70	3.0	0.26	0.6	550	22.6	1.20	18.3	108.0	5.53	3.2	70	2.5	0.13	0.3	500	17.8	13.2	0.74	0.73	20.3	24.4	1.3		
				750	22.9	1.21	18.6	98.3	5.56	2.6					650	18.6	14.9	0.80	0.86	21.5	21.6	1.3		
	4.5	0.60	1.4	550	23.6	1.19	19.3	109.7	5.79	3.4	3.5	0.40	0.9	500	18.0	13.3	0.74	0.71	20.4	25.3	1.4			
				750	24.0	1.19	19.7	99.6	5.90	2.9				650	18.5	14.7	0.80	0.73	21.0	25.5	1.4			
	5.5	0.93	2.1	550	24.2	1.22	19.8	110.7	5.82	3.5	5.0	0.66	1.5	500	18.3	13.6	0.75	0.71	20.7	25.9	1.5			
				750	24.6	1.12	20.2	100.4	6.43	2.9				650	18.8	15.1	0.80	0.72	21.3	26.1	1.5			
80	3.0	0.25	0.6	550	24.8	1.22	20.4	111.8	5.97	3.4	80	2.5	0.13	0.3	500	16.7	12.3	0.73	0.90	19.8	18.6	1.9		
				750	25.2	1.21	20.8	101.1	6.08	2.8					650	17.2	13.6	0.79	0.92	20.3	18.7	2.0		
	4.5	0.57	1.3	550	26.0	1.21	21.7	113.8	6.29	3.6	3.5	0.38	0.9	500	16.8	12.3	0.73	0.88	19.8	19.2	2.1			
				750	26.3	1.20	22.0	102.5	6.42	3.0				650	17.3	13.7	0.79	0.89	20.4	19.4	2.1			
	5.5	0.90	2.1	550	26.4	1.24	21.9	114.4	6.25	3.8	5.0	0.64	1.5	500	17.1	12.6	0.74	0.87	20.1	19.7	2.2			
				750	26.7	1.23	22.2	102.9	6.37	3.2				650	17.6	14.0	0.80	0.89	20.6	19.9	2.5			
90	3.0	0.24	0.6	550	27.1	1.24	22.6	115.5	6.39	3.6	90	2.5	0.12	0.3	500	15.6	11.3	0.73	1.07	19.2	14.6	2.6		
				750	27.3	1.23	22.9	103.7	6.52	2.9					650	16.0	12.5	0.78	1.09	19.7	14.7	2.6		
	4.5	0.55	1.3	550	28.4	1.23	24.0	117.9	6.78	3.8	3.5	0.37	0.9	500	15.7	11.4	0.72	1.04	19.2	15.1	2.7			
				750	28.6	1.21	24.3	105.3	6.92	3.2				650	16.1	12.6	0.78	1.06	19.7	15.2	2.7			
	5.5	0.87	2.0	550	28.6	1.25	24.1	118.1	6.67	4.1	5.0	0.61	1.4	500	16.7	12.0	0.72	1.06	20.3	15.8	2.8			
				750	28.7	1.14	24.3	105.4	7.38	3.4				650	16.4	12.9	0.79	1.05	20.0	15.6	2.8			
100	3.0	0.23	0.5	Operation not recommended							100	2.5	0.12	0.3	500	14.5	10.9	0.75	1.29	18.9	11.2	3.1		
	4.5	0.53	1.2	Operation not recommended								3.5	0.35	0.8	500	14.6	10.9	0.75	1.26	18.9	11.7	3.2		
	5.5	0.84	1.9	Operation not recommended								5.0	0.59	1.4	500	14.9	11.2	0.75	1.25	19.1	11.9	3.3		
110	3.0	0.22	0.5	Operation not recommended							110	2.5	0.11	0.3	500	13.5	10.4	0.77	1.51	18.6	8.9	3.0		
				650	13.8	11.5	0.83	1.54	19.1	9.0					3.0									
	4.5	0.51	1.2	Operation not recommended							3.5	0.34	0.8	500	13.6	10.5	0.77	1.47	18.6	9.2	3.3			
				650	14.0	11.6	0.83	1.50	19.1	9.3				3.2										
	5.5	0.80	1.9	Operation not recommended							5.0	0.57	1.3	500	13.8	10.8	0.78	1.46	18.8	9.5	3.4			
				650	14.2	11.9	0.84	1.49	19.3	9.5				3.4										
120	3.0	0.22	0.5	Operation not recommended							120	2.5	0.11	0.2	500	12.6	10.6	0.84	1.93	19.1	6.5	4.3		
				650	12.8	11.6	0.90	1.97	19.6	6.5					4.4									
	4.5	0.49	1.1	Operation not recommended							3.5	0.33	0.8	500	12.7	10.7	0.84	1.82	18.9	7.0	4.4			
				650	12.9	11.6	0.90	1.87	19.3	6.9				4.4										
	5.5	0.77	1.8	Operation not recommended							5.0	0.55	1.3	500	12.8	10.7	0.83	1.76	18.8	7.3	4.6			
				650	13.1	11.6	0.89	1.82	19.3	7.2				4.6										

Performance capacities shown in thousands of Btu/h.

Performance Data

036 - 100% Full Load

EWT °F	Flow gpm	WPD		HEATING - EAT 70°F							EWT °F	Flow gpm	WPD		COOLING - EAT 80/67 °F							
		PSI	FT	Airflow cfm	HC MBtuh	Power kW	HE MBtuh	LAT °F	COP	HWC MBtuh			PSI	FT	Airflow cfm	TC MBtuh	SC MBtuh	S/T Ratio	Power kW	HR MBtuh	EER	HWC MBtuh
20	5.5	1.09	2.5	Operation not recommended							20	4.5	0.70	1.6	Operation not recommended							
	8.0	2.69	6.2	Operation not recommended								7.0	1.70	3.9	Operation not recommended							
	11.5	3.51	8.1	1150	28.0	2.86	17.8	92.6	2.88	4.7		1500	28.9	2.76	19.0	87.8	3.06	4.3				
30	5.5	1.06	2.5	1150	31.4	2.63	21.9	95.3	3.50	5.2	30	4.5	0.68	1.6	1000	35.7	24.3	0.68	0.99	38.6	36.1	-
				1500	32.3	2.73	22.5	90.0	3.47	4.8					1300	36.3	26.7	0.73	1.03	39.4	35.3	-
	8.0	2.61	6.0	1150	32.2	2.67	22.6	95.9	3.53	5.3		7.0	1.65	3.8	1000	36.2	24.5	0.68	0.94	38.9	38.4	-
				1500	33.1	2.76	23.2	90.5	3.52	4.8		1300	36.7	26.8	0.73	0.99	39.7	37.1	-			
	11.5	3.41	7.9	1150	32.8	2.88	22.5	96.4	3.34	5.4		9.0	2.73	6.3	1000	36.3	24.5	0.68	0.91	39.0	39.8	-
				1500	33.8	2.48	23.8	90.9	4.00	5.0		1300	37.2	26.8	0.72	0.96	40.1	38.9	-			
40	5.5	1.02	2.4	1150	36.3	2.68	26.7	99.2	3.97	5.6	40	4.5	0.66	1.5	1000	37.7	26.2	0.70	1.19	41.3	31.8	-
				1500	37.4	2.74	27.5	93.1	3.99	5.0					1300	38.5	28.7	0.75	1.24	42.2	31.1	-
	8.0	2.53	5.9	1150	37.4	2.73	27.6	100.1	4.02	5.8		7.0	1.60	3.7	1000	38.2	26.5	0.69	1.13	41.6	33.9	-
				1500	38.6	2.79	28.6	93.8	4.05	5.1		1300	38.9	28.9	0.74	1.18	42.5	32.9	-			
	11.5	3.31	7.6	1150	38.2	2.76	28.3	100.7	4.06	5.9		9.0	2.65	6.1	1000	38.5	26.5	0.69	1.09	41.7	35.2	-
				1500	39.4	2.82	29.3	94.3	4.10	5.2		1300	39.3	28.9	0.74	1.14	42.8	34.4	-			
50	5.5	0.99	2.3	1150	41.2	2.73	31.4	103.1	4.43	6.0	50	4.5	0.64	1.5	1000	38.1	25.8	0.68	1.38	42.4	27.7	-
				1500	42.4	2.76	32.5	96.2	4.50	5.6					1300	40.1	28.7	0.72	1.45	44.6	27.7	-
	8.0	2.46	5.7	1150	42.7	2.79	32.7	104.4	4.49	6.5		7.0	1.55	3.6	1000	39.0	26.2	0.67	1.30	42.9	30.0	-
				1500	44.0	2.83	33.9	97.2	4.57	5.7		1300	41.0	29.0	0.71	1.36	45.1	30.1	-			
	11.5	3.20	7.4	1150	43.6	2.81	33.5	105.1	4.55	6.6		9.0	2.56	5.9	1000	39.3	27.9	0.71	1.27	43.2	31.1	-
				1500	45.0	2.85	34.8	97.8	4.63	6.8		1300	41.5	32.2	0.78	1.32	45.0	31.4	-			
60	5.5	0.93	2.2	1150	45.2	2.74	35.4	106.4	4.83	6.1	60	4.5	0.62	1.4	1000	36.6	26.0	0.71	1.58	41.6	23.2	1.9
				1500	46.7	2.76	36.8	98.8	4.95	5.7					1300	38.4	28.9	0.75	1.65	43.6	23.3	2.0
	8.0	2.38	5.5	1150	47.3	2.82	37.1	108.0	4.91	6.7		7.0	1.50	3.5	1000	37.5	26.3	0.70	1.50	42.2	25.0	2.1
				1500	48.8	2.84	38.6	100.1	5.03	5.8		1300	39.3	29.1	0.74	1.56	44.1	25.1	2.1			
	11.5	3.10	7.2	1150	48.4	2.85	38.2	109.0	4.97	6.9		9.0	2.48	5.7	1000	37.9	27.7	0.73	1.46	42.4	25.9	2.0
				1500	50.0	2.86	39.7	100.9	5.12	6.0		1300	39.7	30.7	0.77	1.53	44.5	26.0	2.2			
70	5.5	0.90	2.1	1150	49.3	2.76	39.4	109.7	5.23	6.6	70	4.5	0.60	1.4	1000	35.1	26.1	0.74	1.98	41.4	17.8	2.7
				1500	51.0	2.87	40.7	101.5	5.21	6.2					1300	37.2	30.1	0.81	1.97	43.4	18.9	2.9
	8.0	2.30	5.3	1150	51.9	2.86	41.6	111.8	5.32	6.9		7.0	1.45	3.4	1000	36.0	26.4	0.73	1.70	41.4	21.1	3.1
				1500	53.5	2.86	43.3	103.1	5.50	6.4		1300	37.6	29.2	0.78	1.76	43.1	21.3	3.1			
	11.5	3.00	6.9	1150	53.2	2.89	42.8	112.8	5.39	7.6		9.0	2.40	5.5	1000	36.4	27.4	0.75	1.66	41.6	21.9	3.2
				1500	55.0	2.88	44.7	104.0	5.60	6.6		1300	37.3	29.8	0.80	1.68	43.0	22.2	3.3			
80	5.5	0.87	0.1	1150	52.7	2.82	42.6	112.5	5.49	7.2	80	4.5	0.57	1.3	1000	33.5	25.8	0.77	2.06	40.1	16.3	4.0
				1500	54.6	2.79	44.5	103.7	5.73	6.1					1300	34.9	28.7	0.82	2.12	41.6	16.4	4.0
	8.0	2.22	5.1	1150	55.8	2.93	45.3	114.9	5.59	7.5		7.0	1.40	3.2	1000	34.5	26.1	0.76	1.99	40.8	17.4	4.2
				1500	57.7	2.90	47.3	105.6	5.83	6.3		1300	35.8	29.0	0.81	2.04	42.3	17.5	4.2			
	11.5	2.90	6.7	1150	57.4	2.97	46.7	116.2	5.67	7.7		9.0	2.32	5.4	1000	34.8	26.8	0.77	1.94	41.0	17.9	4.4
				1500	59.4	2.92	48.9	106.6	5.95	7.2		1300	36.3	29.7	0.82	2.00	42.6	18.1	4.4			
90	5.5	0.84	1.9	1150	56.2	2.87	45.9	115.2	5.74	7.4	90	4.5	0.55	1.3	1000	31.9	25.6	0.80	2.33	39.4	13.7	5.3
				1500	58.2	2.82	48.0	105.9	6.04	6.7					1300	33.1	28.4	0.86	2.39	40.7	13.8	5.3
	8.0	2.14	5.0	1150	59.7	3.00	48.9	118.1	5.84	7.8		7.0	1.35	3.1	1000	32.9	25.9	0.79	2.27	40.1	14.5	5.6
				1500	61.8	2.94	51.2	108.2	6.16	7.2		1300	34.1	28.8	0.84	2.32	41.5	14.7	5.6			
	11.5	2.79	6.5	1150	61.6	3.04	50.7	119.6	5.94	8.6		9.0	2.24	5.2	1000	33.5	25.4	0.76	2.24	40.6	15.0	5.9
				1500	63.7	3.02	53.1	109.3	6.18	7.9		1300	34.5	29.0	0.84	2.28	41.8	15.1	5.6			
100	5.5	0.80	1.8	Operation not recommended							100	4.5	0.53	1.2	1000	29.7	24.7	0.83	2.70	38.4	11.0	6.8
	8.0	2.07	4.8	Operation not recommended								7.0	1.30	3.0	1000	30.7	25.0	0.81	2.65	39.3	11.6	7.1
	11.5	2.69	6.2	Operation not recommended								9.0	2.16	5.0	1000	31.0	24.9	0.80	2.61	39.4	11.9	7.5
110	5.5	0.77	1.8	Operation not recommended							110	4.5	0.51	1.2	1000	27.4	23.8	0.87	3.07	37.4	8.9	8.1
				1300	28.2	26.3	0.93	3.11	38.3	9.1					8.0							
	8.0	1.99	4.6	Operation not recommended								7.0	1.25	2.9	1000	28.5	24.0	0.84	3.04	38.4	9.4	8.5
				1300	29.3	26.6	0.91	3.06	39.2	9.6		8.5										
	11.5	2.59	6.0	Operation not recommended								9.0	2.07	4.8	1000	28.8	23.7	0.82	2.99	38.5	9.6	8.9
				1300	29.6	26.1	0.88	3.02	39.4	9.8		8.1										
120	5.5	0.73	1.7	Operation not recommended							120	4.5	0.49	0.8	1000	24.4	23.2	0.95	3.65	36.3	6.7	9.9
				1300	24.9	25.3	1.02	3.73	37.1	6.7					10.2							
	8.0	1.91	4.4	Operation not recommended								7.0	1.20	2.8	1000	24.7	23.4	0.95	3.45	35.9	7.2	10.3
				1300	25.1	25.4	1.01	3.54	36.7	7.1		10.5										
	11.5	2.49	5.8	Operation not recommended								9.0	1.99	4.6	1000	24.9	23.4	0.94	3.34	35.8	7.5	10.7
				1300	25.4	25.4	1.00	3.44	36.7	7.4		10.7										

Performance capacities shown in thousands of Btu/h.

Performance Data

048 - 50% Part Load

EWT °F	Flow gpm	WPD		HEATING - EAT 70°F							EWT °F	Flow gpm	WPD		COOLING - EAT 80/67 °F								
		PSI	FT	Airflow cfm	HC mBtuh	Power kW	HE MBtuh	LAT °F	COP	HWC MBtuh			PSI	FT	Airflow cfm	TC MBtuh	SC MBtuh	S/T Ratio	Power kW	HR MBtuh	EER	HWC MBtuh	
20	3.5	0.56	1.3	Operation not recommended							20	3.0	0.47	1.1	Operation not recommended								
	5.0	0.97	2.2	Operation not recommended								4.5	0.81	1.9	Operation not recommended								
	6.5	1.37	3.2	650	16.5	1.72	10.7	95.4	2.82	2.4		900	16.9	1.55	11.7	89.1	3.19	3.1					
30	3.5	0.55	1.3	650	16.7	1.48	11.8	95.7	3.32	2.7	30	3.0	0.45	1.1	500	22.7	13.7	0.61	0.54	24.8	42.0	-	
				900	17.3	1.50	12.3	89.6	3.38	2.4					750	23.1	15.1	0.65	0.56	25.3	41.1	-	
				650	18.1	1.55	13.0	97.7	3.43	3.0					500	23.0	13.8	0.60	0.51	25.0	44.8	-	
	5.0	0.94	2.2	900	18.6	1.56	13.5	91.0	3.51	2.6		750	23.3	15.1	0.65	0.54	25.5	43.2	-				
				650	18.8	1.75	13.0	98.7	3.15	3.1		500	23.1	13.8	0.60	0.50	25.1	46.4	-				
				900	19.2	1.34	14.7	91.3	4.19	2.6		750	23.7	15.1	0.64	0.52	25.7	45.3	-				
40	3.5	0.53	1.2	650	19.8	1.51	14.9	100.2	3.84	3.0	40	3.0	0.44	1.0	500	25.6	17.5	0.68	0.46	27.5	55.3	-	
				900	20.5	1.52	15.5	92.9	3.94	2.6					750	26.1	19.2	0.73	0.48	28.0	54.1	-	
				650	21.4	1.57	16.3	102.5	3.99	3.3					500	25.9	17.7	0.68	0.44	27.7	58.9	-	
	5.0	0.91	2.1	900	22.1	1.57	17.1	94.6	4.13	2.8		750	26.4	19.3	0.73	0.46	28.3	57.2	-				
				650	22.1	1.58	17.0	103.5	4.09	3.4		500	26.1	17.7	0.68	0.43	27.9	61.2	-				
				900	22.9	1.59	17.7	95.4	4.20	2.8		750	26.7	19.3	0.72	0.45	28.5	59.8	-				
50	3.5	0.51	1.2	650	22.9	1.55	18.0	104.7	4.34	3.3	50	3.0	0.43	1.0	500	24.5	15.8	0.65	0.64	27.0	38.1	-	
				900	23.7	1.55	18.8	96.2	4.48	2.8					750	25.3	18.6	0.74	0.67	27.8	37.7	-	
				650	24.7	1.60	19.7	107.3	4.53	3.6					500	25.0	15.9	0.64	0.56	27.2	45.0	-	
	5.0	0.88	2.0	900	25.7	1.59	20.7	98.3	4.74	3.0		750	25.8	18.7	0.73	0.58	28.1	44.2	-				
				650	25.7	1.61	20.6	108.7	4.68	3.8		500	25.2	15.9	0.63	0.52	27.2	48.0	-				
				900	26.5	1.61	21.5	99.2	4.83	3.3		750	21.3	17.0	0.80	0.41	24.3	52.1	-				
60	3.5	0.50	1.1	650	25.7	1.61	20.7	108.8	4.70	3.7	60	3.0	0.41	1.0	500	23.5	15.4	0.66	0.79	26.5	29.8	1.2	
				900	26.7	1.60	21.7	99.4	4.90	3.0					750	24.2	18.2	0.75	0.82	27.3	29.5	1.2	
				650	27.8	1.65	22.7	111.8	4.96	3.9					500	23.9	15.5	0.65	0.70	26.5	34.2	1.3	
	5.0	0.85	2.0	900	28.9	1.63	23.9	101.7	5.21	3.3		750	24.6	18.3	0.74	0.73	27.4	33.6	1.3				
				650	29.0	1.66	23.9	113.6	5.12	4.1		500	24.2	15.6	0.65	0.66	26.7	36.4	1.4				
				900	30.1	1.64	25.1	102.9	5.37	3.5		750	24.9	18.3	0.74	0.69	27.5	35.9	1.4				
70	3.5	0.48	1.1	650	28.5	1.66	23.4	112.9	5.03	4.0	70	3.0	0.40	0.9	500	22.5	15.0	0.67	0.93	25.9	24.2	1.7	
				900	31.1	1.66	26.1	104.0	5.48	3.3					750	23.4	17.8	0.76	0.98	27.0	23.9	1.8	
				650	31.0	1.69	25.8	116.4	5.36	4.3					500	22.7	15.2	0.67	0.84	25.9	27.0	1.9	
	5.0	0.83	1.9	900	32.2	1.66	27.2	105.2	5.67	3.6		750	23.5	17.9	0.76	0.88	26.7	26.7	1.9				
				650	32.4	1.71	27.2	118.5	5.54	4.5		500	23.1	15.3	0.66	0.80	26.2	28.7	1.9				
				900	33.6	1.71	28.1	108.9	5.76	3.7		750	23.8	17.9	0.75	0.84	27.0	28.5	2.0				
80	3.5	0.46	1.1	650	30.5	1.75	25.1	115.7	5.09	4.2	80	3.0	0.39	0.9	500	21.4	14.5	0.68	1.10	25.4	19.5	2.5	
				900	31.6	1.72	26.4	104.6	5.38	3.5					750	22.1	17.1	0.77	1.15	26.3	19.3	2.5	
				650	33.1	1.77	27.7	119.5	5.47	4.5					500	21.5	14.7	0.68	1.02	25.3	21.1	2.6	
	5.0	0.80	1.8	900	34.4	1.73	29.3	107.5	5.83	3.8		750	22.2	17.3	0.78	1.06	26.1	20.9	2.7				
				650	34.8	1.79	29.4	121.9	5.68	4.8		500	22.0	14.8	0.67	0.98	25.6	22.6	2.8				
				900	36.2	1.74	31.0	109.3	6.08	4.0		750	22.7	17.4	0.77	1.02	26.4	22.3	3.2				
90	3.5	0.45	1.0	650	32.4	1.84	26.7	118.4	5.15	4.5	90	3.0	0.37	0.9	500	20.3	14.0	0.69	1.26	24.9	16.1	3.4	
				900	33.6	1.80	28.2	106.7	5.47	3.7					750	21.0	16.5	0.79	1.31	25.7	16.0	3.4	
				650	35.2	1.85	29.6	122.5	5.56	4.8					500	20.3	14.2	0.70	1.20	24.7	17.0	3.5	
	5.0	0.77	1.8	900	36.7	1.79	31.4	109.9	5.99	4.0		750	20.9	16.7	0.80	1.24	25.4	16.9	3.6				
				650	37.1	1.87	31.6	125.4	5.81	5.2		500	19.5	13.4	0.69	1.21	23.8	16.1	3.7				
				900	38.7	1.69	36.4	112.5	6.70	4.3		750	20.1	16.9	0.84	1.27	26.1	15.8	3.7				
100	3.5	0.43	1.0	Operation not recommended							100	3.0	0.36	0.8	500	18.4	12.9	0.70	1.48	23.7	12.4	4.3	
	5.0	0.74	1.7	Operation not recommended								4.5	0.62	1.4	750	18.9	15.1	0.80	1.54	24.4	12.3	4.3	
	6.5	1.05	2.4	Operation not recommended								6.0	0.89	2.1	500	18.2	13.0	0.71	1.44	23.4	12.7	4.4	
110	3.5	0.41	1.0	Operation not recommended							110	3.0	0.35	0.8	500	16.4	11.7	0.71	1.69	22.4	9.7	5.0	
				750	16.8	13.7	0.82	1.76	23.1	9.6					5.0								
				500	16.1	11.8	0.73	1.68	22.1	9.6					5.4								
	5.0	0.71	1.6	Operation not recommended								4.5	0.60	1.4	750	16.7	13.9	0.84	1.75	22.9	9.5	5.4	
				6.0	0.86	2.0	500	16.9	12.1	0.71		1.63	22.7	10.4	5.8								
				750	17.4	14.2	0.81	1.70	23.4	10.2		5.8											
120	3.5	0.40	0.9	Operation not recommended							120	3.0	0.33	0.8	500	15.2	12.4	0.82	2.10	22.6	7.2	6.4	
				750	15.5	13.5	0.87	2.15	23.1	7.2					6.5								
				500	15.4	12.5	0.81	1.99	22.4	7.7					6.6								
	5.0	0.68	1.6	Operation not recommended								4.5	0.58	1.3	750	15.7	13.6	0.87	2.04	22.9	7.7	6.6	
				6.0	0.82	1.9	500	15.5	12.5	0.81		1.92	22.3	8.1	6.8								
				750	15.9	14.8	0.94	1.98	23.0	8.0		6.8											

Performance capacities shown in thousands of Btuh.

Performance Data

060 - 50% Part Load

EWT °F	Flow gpm	WPD		HEATING - EAT 70°F							EWT °F	Flow gpm	WPD		COOLING - EAT 80/67 °F								
		PSI	FT	Airflow cfm	HC mBtuh	Power kW	HE MBtuh	LAT °F	COP	HWC MBtuh			PSI	FT	Airflow cfm	TC MBtuh	SC MBtuh	S/T Ratio	Power kW	HR MBtuh	EER	HWC MBtuh	
20	4.5	0.63	1.5	Operation not recommended							20	4.0	0.43	1.0	Operation not recommended								
	6.3	1.17	2.7	Operation not recommended								6.0	1.22	2.8	Operation not recommended								
	8.5	1.94	4.5	850	21.0	2.18	13.5	92.9	2.82	3.4		1100	21.4	2.02	14.5	88.0	3.10	3.1					
30	4.5	0.61	1.4	850	23.8	2.01	16.9	95.9	3.47	3.9	30	4.0	0.42	1.0	700	29.9	17.4	0.58	0.73	32.8	41.2	-	
				1100	24.6	2.03	17.7	90.7	3.54	3.4					950	30.5	19.1	0.63	0.76	33.4	40.3	-	
	6.3	1.14	2.6	850	23.6	2.03	16.7	95.7	3.40	4.1		700	30.4	17.6	0.58	0.69	33.1	44.0	-				
				1100	24.5	2.06	17.4	90.6	3.48	3.5		950	30.8	19.2	0.62	0.73	33.7	42.4	-				
	8.5	1.89	4.4	850	24.8	2.22	17.2	97.0	3.27	4.2		700	30.5	17.6	0.58	0.67	33.1	45.6	-				
1100				25.3	2.06	18.3	91.3	3.60	3.6	950	31.3	19.2	0.61	0.70	34.0	44.5	-						
40	4.5	0.60	1.4	850	27.5	2.05	20.5	100.0	3.94	4.3	40	4.0	0.41	0.9	700	30.9	19.9	0.64	0.77	33.9	39.9	-	
				1100	28.4	2.06	21.3	93.9	4.03	3.7					950	31.5	21.8	0.69	0.81	34.6	39.1	-	
	6.3	1.10	2.5	850	27.7	2.08	20.6	100.2	3.90	4.5		700	31.3	20.1	0.64	0.73	34.1	42.5	-				
				1100	28.5	2.09	21.4	94.0	4.00	3.8		950	31.8	21.9	0.69	0.77	34.8	41.3	-				
	8.5	1.83	4.2	850	28.6	2.09	21.5	101.2	4.02	4.7		700	31.5	20.1	0.64	0.71	34.3	44.2	-				
1100				29.4	2.10	22.3	94.7	4.11	3.9	950	32.2	21.9	0.68	0.75	35.1	43.2	-						
50	4.5	0.58	1.3	850	31.3	2.09	24.2	104.1	4.39	4.7	50	4.0	0.40	0.9	700	32.0	21.5	0.67	0.80	35.1	40.3	-	
				1100	32.2	2.09	25.0	97.1	4.51	3.9					950	33.0	24.5	0.74	0.84	36.2	39.3	-	
	6.3	1.07	2.5	850	31.8	2.13	24.5	104.6	4.38	4.9		700	32.1	21.7	0.68	0.77	35.1	41.9	-				
				1100	32.5	2.12	25.3	97.4	4.50	4.1		950	33.1	24.6	0.75	0.80	36.2	41.2	-				
	8.5	1.77	4.1	850	32.8	2.14	25.5	105.7	4.48	5.2		700	32.2	21.7	0.67	0.75	35.2	42.8	-				
1100				33.5	2.13	26.2	98.2	4.61	4.6	950	32.8	24.4	0.74	0.67	36.1	49.0	-						
60	4.5	0.56	1.3	850	35.3	2.13	28.0	108.5	4.86	5.1	60	4.0	0.38	0.9	700	31.1	21.2	0.68	0.98	34.8	31.8	1.5	
				1100	36.1	2.11	28.9	100.4	5.01	4.2					950	32.0	24.0	0.75	1.02	35.9	31.3	1.6	
	6.3	1.03	2.4	850	36.4	2.17	29.0	109.7	4.92	5.3		700	31.2	21.4	0.69	0.95	34.8	33.0	1.7				
				1100	37.0	2.14	29.7	101.1	5.07	4.5		950	32.2	24.2	0.75	0.99	35.9	32.5	1.7				
	8.5	1.72	4.0	850	37.3	2.19	29.8	110.6	5.00	5.6		700	31.4	21.5	0.68	0.93	34.9	33.9	1.8				
1100				37.9	2.16	30.5	101.9	5.15	4.7	950	32.3	24.3	0.75	0.97	36.0	33.3	1.8						
70	4.5	0.54	1.2	850	39.3	2.17	31.9	112.8	5.31	5.4	70	4.0	0.37	0.9	700	30.1	20.9	0.70	1.16	34.4	26.0	2.1	
				1100	38.6	2.15	31.3	102.5	5.26	4.5					950	31.4	24.0	0.76	1.32	36.2	23.7	2.3	
	6.3	1.00	2.3	850	41.0	2.20	33.5	114.6	5.45	5.8		700	30.3	21.1	0.70	1.13	34.5	27.0	2.4				
				1100	41.4	2.16	34.1	104.9	5.63	4.8		950	31.3	23.8	0.76	1.17	35.6	26.6	2.4				
	8.5	1.66	3.8	850	41.8	2.23	34.1	115.5	5.49	6.0		700	30.5	21.2	0.70	1.10	34.6	27.7	2.5				
1100				42.2	2.18	34.8	105.5	5.67	5.0	950	31.2	23.8	0.76	1.14	35.4	27.4	2.5						
80	4.5	0.52	1.2	850	42.9	2.23	35.3	116.7	5.64	5.8	80	4.0	0.36	0.8	700	28.4	20.5	0.72	1.38	33.4	20.6	3.1	
				1100	43.3	2.18	35.8	106.4	5.81	4.8					950	29.3	22.9	0.78	1.42	34.5	20.5	3.2	
	6.3	0.97	2.2	850	45.3	2.27	37.6	119.3	5.86	6.2		700	28.6	20.7	0.72	1.34	33.6	21.3	3.3				
				1100	45.5	2.20	38.0	108.3	6.06	5.1		950	29.5	23.2	0.79	1.39	34.6	21.2	3.4				
	8.5	1.60	3.7	850	45.8	2.30	38.0	119.9	5.85	6.6		700	28.8	20.9	0.72	1.32	33.7	21.8	3.5				
1100				46.0	2.23	38.4	108.7	6.05	5.4	950	29.7	23.3	0.78	1.37	34.8	21.7	4.0						
90	4.5	0.50	1.2	850	46.5	2.29	38.6	120.6	5.94	6.2	90	4.0	0.34	0.8	700	26.6	20.1	0.75	1.60	32.4	16.7	4.4	
				1100	46.6	2.23	39.0	109.2	6.12	5.0					950	27.4	22.3	0.81	1.64	33.4	16.7	4.4	
	6.3	0.93	2.2	850	49.6	2.33	41.6	124.0	6.24	6.6		700	26.9	20.3	0.75	1.56	32.6	17.3	4.6				
				1100	49.6	2.24	41.9	111.7	6.48	5.4		950	27.7	22.6	0.82	1.61	33.6	17.2	4.6				
	8.5	1.55	3.6	850	49.9	2.36	41.8	124.4	6.19	7.1		700	26.8	18.8	0.70	1.59	32.5	16.9	4.8				
1100				49.8	2.28	42.0	111.9	6.40	5.8	950	28.2	22.7	0.80	1.64	33.2	17.2	4.8						
100	4.5	0.48	1.1	Operation not recommended							100	4.0	0.33	0.8	700	24.8	19.5	0.79	1.92	31.7	12.9	5.4	
	6.3	0.90	2.1	Operation not recommended								6.0	0.93	2.2	950	25.6	21.6	0.84	1.97	32.6	13.0	5.4	
	8.5	1.49	3.4	Operation not recommended								7.5	1.38	3.2	700	25.1	19.7	0.79	1.89	31.9	13.3	5.5	
110	4.5	0.47	1.1	Operation not recommended							110	4.0	0.32	0.7	700	23.0	19.0	0.83	2.24	30.9	10.2	6.3	
				950	23.7	20.8	0.88	2.29	31.8	10.4					6.3								
	6.3	0.86	2.0	Operation not recommended								6.0	0.90	2.1	700	23.3	19.2	0.82	2.22	31.2	10.5	6.8	
				950	24.0	21.0	0.88	2.27	32.1	10.6		6.8											
	8.5	1.43	3.3	Operation not recommended								7.5	1.33	3.1	700	23.6	19.5	0.83	2.19	31.4	10.8	7.2	
950				24.3	21.3	0.88	2.23	32.3	10.9	7.2													
120	4.5	0.45	1.0	Operation not recommended							120	4.0	0.31	0.7	700	22.4	18.7	0.83	2.74	32.1	8.2	8.2	
				950	22.9	20.4	0.89	2.80	32.8	8.2					8.2								
	6.3	0.83	1.9	Operation not recommended								6.0	0.86	2.0	700	22.7	18.9	0.83	2.59	31.8	8.8	8.4	
				950	23.1	20.5	0.89	2.66	32.5	8.7		8.4											
8.5	1.38	3.2	Operation not recommended							7.5	1.28	3.0	700	22.9	18.9	0.82	2.51	31.8	9.1	8.7			
			950	22.3	20.3	0.91	2.53	30.0	8.8	8.7													

Performance capacities shown in thousands of Btuh.

Service Parts List

Parts List - Horizontal		024	036	048	060
Compressor	Compressor 208-230/60/1	34P676-01	34P676-01	34P677-01	34P678-01
	Sound Jacket	92P504A05	92P504A05	92P504A05	92P504A05
	Power Harness	11P853-01	11P853-01	11P853-01	11P853-01
ECM EON Motor & Blower	ECM Motor 208-230/60/1	14S575-01	14S575-01	14S576-01	14S577-01
	ECM Blower Housing	53P501B01	53P501B01	53P501B01	53P501B01
	ECM Harness - Low Voltage	11P827-01	11P827-01	11P827-01	11P827-01
	ECM Power Harness	11P585B04	11P585B04	11P585B04	11P585B04
Air Filters	2" Air Filter MERV 11	59P509-02	59P509-02	59P509-02	59P509-03
	2" Air Filter MERV 11 (second filter if needed)	59P509-11	59P509-11	59P509-11	59P509-11
Refrigeration Components	Air Coil	61P775-41S	61P775-41S	61P775-41S	61P776-41S
	Coax	62I628-01	62I628-01	62I555-01	62I555-01
	EEV	33P617-01	33P617-01	33P617-01	33P617-01
	Reversing Valve	33P526-05	33P526-05	33P526-05	33P526-05
	Discharge Muffler	36P503B02	36P503B02	36P503B02	36P503B02
	Filter Dryer	36P500B01	36P500B01	36P500B02	36P500B02
Hot Water Generator	Hot Water Generator	62P516-03	62P516-03	62P516-03	62P516-03
	Hot Water Generator Pump	24P501A01	24P501A01	24P501A01	24P501A01
Electrical	2 POLE CONTACTOR 24 VAC-40A	13P521-01	13P521-01	13P521-01	13P521-01
	TRNSFMR 100VAC 208-240 24V LEAD	15P531-01	15P531-01	15P531-01	15P531-01
	3 Pole Power Block	12P503-06	12P503-06	12P503-06	12P503-06
	2 Pole Screw Term. Block	12P500A01	12P500A01	12P500A01	12P500A01
	EEV Solenoid Coil	33P617-02	33P617-02	33P617-02	33P617-02
	EEV/VS Drive Communication Cable	11P843-01	11P843-01	11P843-01	11P843-01
	ASB/ABC/AXB/Drive Communication Harness	11P836-02	11P836-02	11P836-02	11P836-02
	RDS/ASB Harness	11P991-02	11P991-02	11P991-02	11P991-02
	Keystone Category 5 Coupler (AID Port)	12P553-01	12P553-01	12P553-01	12P553-01
	Category 5 cable (AID Port to ABC)	11P846-01	11P846-01	11P846-01	11P846-01
	Current Transformer	12P557-01	12P557-01	12P557-01	12P557-01
	Rocker Switch - HWG ON/OFF	13P607A01	13P607A01	13P607A01	13P607A01
	Pump Circuit Breaker - 5 amp, 250v	19P583-01	19P583-01	19P583-01	19P583-01
	Pressure Transmitter DIN Cable	11P855-01	11P855-01	11P855-01	11P855-01
	VS Drive Control	17P560-07	17P560-07	17P560-08	17P560-09
	Drive Circuit Breaker	19P595-01	19P595-01	19P595-02	19P595-03
ABC Board	17X553-36	17X553-36	17X553-36	17X553-36	
AXB Board	17X597-26	17X597-26	17X597-26	17X597-26	
ASB Board	17P599-01	17P599-01	17P599-01	17P599-01	
Sensors & Safeties	Freeze Detection Thermistor-FP1-Yellow	FP1RK01	FP1RK01	FP1RK01	FP1RK01
	HWL Thermistor-Pink (AXB P17)	12P555-04	12P555-04	12P555-04	12P555-04
	Thermistor FP2	12P550-01	12P550-01	12P550-01	12P550-01
	Thermistor - LAT/EWT/Suct Line/Compr Ambient	12P556-01	12P556-01	12P556-01	12P556-01
	Thermistor - Suction Line	12P505-17	12P505-17	12P505-17	12P505-17
	Thermistor - Compressor Discharge Line	12P556-02	12P556-02	12P556-02	12P556-02
	Thermistor - Heating Liquid Line	12P555-03	12P555-03	12P555-03	12P555-03
	Thermistor - Leaving Water Temperature	12P555-02	12P555-02	12P555-02	12P555-02
	Transmitter, Flow Meter (sensor, clip, harness)	29P535-01	29P535-01	29P535-01	29P535-01
	Pressure Transducer Replacement, High and Low Pressure	35P558-01	35P558-01	35P558-01	35P558-01
	Switch, High Pressure	SKHPE600	SKHPE600	SKHPE600	SKHPE600
	Switch, Low Pressure	SKLPE40	SKLPE40	SKLPE40	SKLPE40
Refrigerant Detection Sensor	19P688-01	19P688-01	19P688-01	19P688-01	
Misc.	VS Drive Fan Filter	59P512-01	59P512-01	59P512-01	59P512-01

Part numbers subject to change

7/11/24

Service Parts List

Parts List - Vertical		024	036	048	060
Compressor	Compressor 208-230/60/1	34P676-01	34P676-01	34P677-01	34P678-01
	Sound Jacket	92P504A05	92P504A05	92P504A05	92P504A05
	Power Harness	11P853-01	11P853-01	11P853-01	11P853-01
ECM Motor & Blower	ECM Motor 208-230/60/1	14S575-01	14S575-01	14S576-01	14S577-01
	ECM Blower Housing	53P501B01	53P501B01	53P501B01	53P501B01
	ECM Harness - Low Voltage	11P827-02	11P827-02	11P827-02	11P827-02
	ECM Power Harness	11P585B03	11P585B03	11P585B03	11P585B03
Air Filters	2" Air Filter MERV 11 (top flow & rear discharge)	59P509-07	59P509-07	59P509-07	59P509-06
	2" Air Filter MERV 11 (bottom flow)	59P509-06	59P509-06	59P509-06	59P509-06
	AP411 4" Media Refill	RM-AP411-46	RM-AP411-46	RM-AP411-46	RM-AP411-46
	AP411 1" Carbon Media Refill	RM-AP411-46C	RM-AP411-46C	RM-AP411-46C	RM-AP411-46C
Refrigeration Components	Air Coil	61P773-41S	61P773-41S	61P773-41S	61P772-41S
	Coax	62I628-01	62I628-01	62I555-01	62I555-01
	EEV	33P617-01	33P617-01	33P617-01	33P617-01
	Reversing Valve	33P526-05	33P526-05	33P526-05	33P526-05
	Discharge Muffler	36P503B02	36P503B02	36P503B02	36P503B02
	Filter Dryer	36P500B01	36P500B01	36P500B02	36P500B02
Hot Water Generator	Hot Water Generator	62P516-03	62P516-03	62P516-03	62P516-03
	Hot Water Generator Pump	24P501A01	24P501A01	24P501A01	24P501A01
Electrical	2 POLE CONTACTOR 24 VAC-40A	13P521-01	13P521-01	13P521-01	13P521-01
	TRNSFMR 100VAC 208-240 24V LEAD	15P531-01	15P531-01	15P531-01	15P531-01
	3 Pole Power Block	12P503-06	12P503-06	12P503-06	12P503-06
	2 Pole Screw Term. Block	12P500A01	12P500A01	12P500A01	12P500A01
	EEV Solenoid Coil	33P617-02	33P617-02	33P617-02	33P617-02
	ASB/ABC/AXB/Drive Communication Harness	11P836-02	11P836-02	11P836-02	11P836-02
	RDS/ASB Harness	11P991-02	11P991-02	11P991-02	11P991-02
	Keystone Category 5 Coupler (AID Port)	12P553-01	12P553-01	12P553-01	12P553-01
	Category 5 cable (AID Port to ABC)	11P846-01	11P846-01	11P846-01	11P846-01
	Current Transformer	12P557-01	12P557-01	12P557-01	12P557-01
	Rocker Switch - HWG ON/OFF	13P607A01	13P607A01	13P607A01	13P607A01
	Pump Circuit Breaker - 5 amp, 250v	19P583-01	19P583-01	19P583-01	19P583-01
	Pressure Transmitter DIN Cable	11P855-01	11P855-01	11P855-01	11P855-01
	VS Drive Control	17P560-07	17P560-07	17P560-08	17P560-09
	Drive Circuit Breaker	19P595-01	19P595-01	19P595-02	19P595-03
	ABC Board	17X553-36	17X553-36	17X553-36	17X553-36
AXB Board	17X597-26	17X597-26	17X597-26	17X597-26	
ASB Board	17P599-01	17P599-01	17P599-01	17P599-01	
Sensors & Safeties	Freeze Detection Thermistor-FP1-Yellow	FP1RK01	FP1RK01	FP1RK01	FP1RK01
	HWL Thermistor-Pink (AXB P17)	12P555-04	12P555-04	12P555-04	12P555-04
	Thermistor FP2	12P550-01	12P550-01	12P550-01	12P550-01
	Thermistor - LAT/EWT/Suct Line/Compr Ambient	12P556-01	12P556-01	12P556-01	12P556-01
	Thermistor - Suction Line	12P505-17	12P505-17	12P505-17	12P505-17
	Thermistor - Compressor Discharge Line	12P556-02	12P556-02	12P556-02	12P556-02
	Thermistor - Heating Liquid Line	12P555-03	12P555-03	12P555-03	12P555-03
	Thermistor - Leaving Water Temperature	12P555-02	12P555-02	12P555-02	12P555-02
	Transmitter, Flow Meter (sensor, clip, harness)	29P535-01	29P535-01	29P535-01	29P535-01
	Pressure Transducer Replacement, High and Low Pressure	35P558-01	35P558-01	35P558-01	35P558-01
	Switch, High Pressure	SKHPE600	SKHPE600	SKHPE600	SKHPE600
Switch, Low Pressure	SKLPE40	SKLPE40	SKLPE40	SKLPE40	
Refrigerant Detection Sensor	19P688-01	19P688-01	19P688-01	19P688-01	
Miscellaneous	VS Drive Fan Filter	59P512-01	59P512-01	59P512-01	59P512-01

Part numbers subject to change

7/11/24

Decommissioning

Before carrying out this procedure, it is essential that the technician is completely familiar with the equipment and all its detail. It is recommended good practice that all refrigerants are recovered safely. Prior to the task being carried out, an oil and refrigerant sample shall be taken in case analysis is required prior to re-use of recovered refrigerant. It is essential that electrical power is available before the task is commenced.

1. Become familiar with the equipment and its operation.
2. Isolate system electrically.
3. Before attempting the procedure, ensure that:
 - mechanical handling equipment is available, if required, for handling refrigerant cylinders;
 - all personal protective equipment is available and being used correctly;
 - the recovery process is supervised at all times by a competent person;
 - recovery equipment and cylinders conform to the appropriate standards.
4. Pump down refrigerant system, if possible.
5. If a vacuum is not possible, make a manifold so that refrigerant can be removed from various parts of the system.
6. Make sure that cylinder is situated on the scales before recovery takes place.
7. Start the recovery machine and operate in accordance with instructions.
8. Do not overfill cylinders (no more than 80 % volume liquid charge).
9. Do not exceed the maximum working pressure of the cylinder, even temporarily.
10. When the cylinders have been filled correctly and the process completed, make sure that the cylinders and the equipment are removed from site promptly and all isolation valves on the equipment are closed off.
11. Recovered refrigerant shall not be charged into another REFRIGERATING SYSTEM unless it has been cleaned and checked

Decommissioning - Unit Labeling Requirements

Equipment shall be labelled stating that it has been de-commissioned and emptied of refrigerant. The label shall be dated and signed. For appliances containing FLAMMABLE REFRIGERANTS, ensure that there are labels on the equipment stating the equipment contains FLAMMABLE REFRIGERANT.

Refrigerant Recovery

When removing refrigerant from a system, either for servicing or decommissioning, it is recommended good practice that all refrigerants are removed safely.

When transferring refrigerant into cylinders, ensure that only appropriate refrigerant recovery cylinders are employed. Ensure that the correct number of cylinders for holding the total system charge is available. All cylinders to be used are designated for the recovered refrigerant and labelled for that refrigerant (i.e. special cylinders for the recovery of refrigerant). Cylinders shall be complete with pressure-relief valve and associated shut-off valves in good working order. Empty recovery cylinders are evacuated and, if possible, cooled before recovery occurs.

The recovery equipment shall be in good working order with a set of instructions concerning the equipment that is at hand and shall be suitable for the recovery of the flammable refrigerant. If in doubt, the manufacturer should be consulted. In addition, a set of calibrated weighing scales shall be available and in good working order. Hoses shall be complete with leak-free disconnect couplings and in good condition.

The recovered refrigerant shall be processed according to local legislation in the correct recovery cylinder, and the relevant waste transfer note arranged. Do not mix refrigerants in recovery units and especially not in cylinders.

If compressors or compressor oils are to be removed, ensure that they have been evacuated to an acceptable level to make certain that flammable refrigerant does not remain within the lubricant. The compressor body shall not be heated by an open flame or other ignition sources to accelerate this process. When oil is drained from a system, it shall be carried out safely.

Refrigerant Removal and Evacuation

When breaking into the refrigerant circuit to make repairs – or for any other purpose conventional procedures shall be used. However, for flammable refrigerants it is important that best practice be followed, since flammability is a consideration.

The following procedure shall be adhered to:

- safely remove refrigerant following local and national regulations;
- evacuate;
- purge the circuit with inert gas (optional for A2L);
- evacuate (optional for A2L);
- continuously flush or purge with inert gas when using flame to open circuit; and
- open the circuit.

The refrigerant charge shall be recovered into the correct recovery cylinders if venting is not allowed by local and national codes. For appliances containing flammable refrigerants, the system shall be purged with oxygen-free nitrogen to render the appliance safe for flammable refrigerants.

This process might need to be repeated several times. Compressed air or oxygen shall not be used for purging refrigerant systems. For appliances containing flammable refrigerants, refrigerants purging shall be achieved by breaking the vacuum in the system with oxygen-free nitrogen and continuing to fill until the working pressure is achieved, then venting to atmosphere, and finally pulling down to a vacuum (optional for A2L). This process shall be repeated until no refrigerant is within the system (optional for A2L). When the final oxygen-free nitrogen charge is used, the system shall be vented down to atmospheric pressure to enable work to take place. The outlet for the vacuum pump shall not be close to any potential ignition sources, and ventilation shall be available.

Charging procedures

In addition to conventional charging procedures, the following requirements shall be followed.

- Ensure that contamination of different refrigerants does not occur when using charging equipment.
- Hoses or lines shall be as short as possible to minimise the amount of refrigerant contained in them.
- Cylinders shall be kept in an appropriate position according to the instructions.
- Ensure that the REFRIGERATING SYSTEM is earthed prior to charging the system with refrigerant.
- Label the system when charging is complete (if not already).
- Extreme care shall be taken not to overfill the REFRIGERATING SYSTEM.

Prior to recharging the system, it shall be pressure-tested with the appropriate purging gas. The system shall be leak-tested on completion of charging but prior to commissioning. A follow up leak test shall be carried out prior to leaving the site.

Notes

Revision Guide

Pages:	Description:	Date:	By:
All	Document Creation	16 Feb 2024	SW

GEOSMART ENERGY



1-975 Bleams Road, Kitchener, ON N2E 3Z5, Canada | o: 1.866.310.6690 | f: 1.866.533.3889

GEOSMARTENERGY.COM



Product: **Premium V Series**
Type: Variable Speed Geothermal/Water Source Heat Pumps
Size: 3 - 5 Ton Variable Speed

Document Type: Operation and Maintenance
Ref. Number: OMW7-0018S
Revision Date: 07/24
Revision Number: 1
Document Name:

Informations générales sur l'installation	2
Nomenclature.....	7
Qualité de l'eau	13
Raccords du générateur d'eau chaude.....	14
Raccords électriques	16
Installation du thermostat électronique.....	18
Données sur le rendement du ventilateur.....	19
Données dimensionnelles.....	20
Données physiques.....	24
Calculs de référence.....	25
Limites de fonctionnement.....	25
Retrait et évacuation du réfrigérant.....	26
Procédures de chargement.....	26
Récupération du réfrigérant.....	27
Démarrage de l'unité.....	28
Guide de révision.....	33

AVERTISSEMENT

AVERTISSEMENT : Avant d'effectuer toute opération d'entretien ou de maintenance du système, coupez l'alimentation principale de l'unité. Le choc électrique peut provoquer de graves blessures.

AVERTISSEMENT : Tous les produits WaterFurnace sont conçus, testés et fabriqués dans le respect de l'édition la plus récente, publiée et disponible, de la norme UL 60335-2-40 relative à la certification de la sécurité électrique. Tous les raccords électriques doivent être conformes aux normes du code national de l'électricité (NEC) et/ou à tout autre code local applicable à l'installation.

AVERTISSEMENT : Seul le personnel autorisé par l'usine est habilité à procéder au démarrage, au test de vérification et à la mise en service de cette unité.

INSTALLATEUR : Veuillez prendre le temps de lire et de comprendre ces instructions avant toute installation. L'installateur est tenu de remettre une copie de ce manuel au propriétaire.

Pour l'utilisateur

AVERTISSEMENT

Cet appareil ne doit pas être utilisé par des personnes (y compris les enfants) ayant des capacités physiques, sensorielles ou mentales réduites, ou n'ayant ni expérience ni compétence nécessaire, à moins que celles-ci ne bénéficient d'une surveillance ou d'instructions concernant l'utilisation de l'appareil de la part d'une personne responsable chargée de veiller à leur sécurité.

Les enfants doivent être sous surveillance afin de s'assurer qu'ils ne jouent pas avec l'appareil.

Gardez ce manuel dans un endroit sûr afin de permettre à votre technicien de disposer des informations nécessaires.

AVIS

AVIS : Pour éviter d'endommager l'équipement, ne laissez pas le système rempli dans un bâtiment sans chauffage par temps froid, à moins de prévoir des niveaux d'antigel adéquats pour la protection contre le gel. En effet, les échangeurs de chaleur ne se vident pas complètement et gèlent s'ils ne sont pas protégés, ce qui peut entraîner des dommages permanents.

Définition des avertissements et des symboles

 DANGER	Indique une situation entraînant des blessures graves ou mortelles.
 AVERTISSEMENT	Indique une situation qui pourrait entraîner des blessures graves ou mortelles.
 ATTENTION	Indique une situation qui pourrait entraîner des blessures légères ou modérées.
AVIS	Indique une situation qui pourrait endommager l'équipement ou la propriété.



Informations générales sur l'installation

AVIS : Ne pas installer les unités dans un environnement corrosif ou dans des endroits soumis à des températures extrêmes ou à l'humidité élevée. Les conditions corrosives et des températures extrêmes ou à l'humidité élevée peuvent réduire de manière significative le rendement, la fiabilité et la durée de vie de l'appareil.

AVIS : Il doit y avoir un espace libre minimal de 61 cm (24 po) pour accéder au panneau d'accès avant.

AVIS : Pour éviter d'endommager le matériel, N'UTILISEZ PAS ces unités comme source de chauffage ou de refroidissement pendant le processus de construction. Les composants mécaniques et les filtres peuvent rapidement être obstrués par la saleté et les débris de construction, ce qui peut endommager le système et annuler la garantie du produit.

Pour l'installateur

Si vous n'êtes PAS certain de savoir comment installer ou faire fonctionner l'unité, contactez votre fournisseur.

L'installation et l'entretien des appareils de climatisation et de chauffage peuvent être dangereux en raison de la pression du système et des composants électriques. Seul un personnel formé et qualifié est habilité à procéder à l'installation, à la réparation ou à l'entretien des appareils de chauffage et de climatisation. Lors d'une intervention sur un appareil de chauffage ou de climatisation, veillez à respecter les précautions indiquées dans la documentation, les étiquettes apposées sur l'appareil et les autres mesures de sécurité éventuellement applicables.

Ce manuel contient des informations spécifiques sur la qualification requise du personnel pour les opérations de maintenance, d'entretien et de réparation. Toute procédure de travail touchant les moyens de sécurité ne doit être effectuée que par des personnes compétentes.

Voici quelques exemples de ces procédures de travail :

- ouvrir le circuit frigorifique;
- ouvrir des composants scellés ou des boîtiers ventilés.

Respectez tous les codes de sécurité. Portez des lunettes de sécurité et des gants de travail. Utilisez un chiffon mouillé pour toute opération de brasage. Ayez un extincteur à disposition pour toute opération de brasage. Suivez toutes les procédures pour rester en conformité avec les réglementations nationales relatives aux gaz.

Avant de commencer à travailler sur des systèmes contenant des RÉFRIGÉRANTS INFLAMMABLES, des contrôles de sécurité sont nécessaires pour s'assurer que le risque d'inflammation est minimisé. Les travaux doivent être entrepris selon une procédure contrôlée de manière à minimiser le risque de présence de gaz ou de vapeur inflammable pendant l'exécution des travaux. Le personnel de maintenance et les autres personnes travaillant dans la zone locale doivent être informés de la nature des travaux effectués. Les travaux dans des espaces confinés doivent être évités.

La zone doit être contrôlée à l'aide d'un détecteur de réfrigérant approprié avant et pendant le travail, afin de s'assurer que le technicien est conscient de la présence d'atmosphères potentiellement toxiques ou inflammables. Assurez-vous que le matériel de détection des fuites utilisé convient à une utilisation avec tous les réfrigérants applicables, c'est-à-dire qu'il ne projette pas d'étincelles, qu'il est correctement scellé et intrinsèquement sûr.

Si des travaux à chaud doivent être effectués sur le matériel de réfrigération ou toute pièce associée, un matériel d'extinction

d'incendie approprié doit être à portée de main. Gardez un extincteur à poudre sèche ou à CO₂ à proximité de la zone de chargement.

Aucune personne effectuant des travaux sur un SYSTÈME FRIGORIFIQUE impliquant l'exposition d'une tuyauterie ne doit utiliser des sources d'inflammation de manière à présenter un risque d'incendie ou d'explosion. Toutes les sources d'inflammation possibles, y compris l'usage de la cigarette, doivent être maintenues suffisamment loin du site d'installation, de réparation, de retrait et d'élimination, lorsque du réfrigérant peut éventuellement être libéré dans l'espace environnant. Avant de commencer le travail, la zone autour du matériel doit être inspectée pour s'assurer qu'il n'y a pas de risques d'inflammation. Des panneaux « Interdiction de fumer » doivent être affichés.

Lorsque des composants électriques sont remplacés, ils doivent convenir à l'usage prévu et aux spécifications. Les directives d'entretien et de maintenance du fabricant doivent être respectées en tout temps. En cas de doute, consultez le service du soutien technique du fabricant pour obtenir de l'aide.

Les contrôles suivants doivent être appliqués aux installations utilisant des RÉFRIGÉRANTS INFLAMMABLES :

- la CHARGE RÉELLE DE FRIGORIGÈNE est conforme à la taille de la salle dans laquelle les pièces contenant le réfrigérant sont installées;
- le matériel et les sorties de ventilation fonctionnent correctement et ne sont pas obstrués;
- si un circuit frigorifique indirect est utilisé, le circuit secondaire doit être contrôlé pour vérifier la présence de réfrigérant;
- les mentions du matériel demeurent visibles et lisibles. Les mentions et signes illisibles doivent être corrigés;
- les tuyaux ou composants de refroidissement sont installés dans un endroit où ils ne risquent pas d'être exposés à une substance susceptible de corroder les composants contenant du réfrigérant, à moins que les composants ne soient construits en matériaux intrinsèquement résistants à la corrosion ou convenablement protégés contre cette corrosion.

AVERTISSEMENT

Si l'appareil se verrouille sur E5 : PROTECTION CONTRE LE GEL FP1. L'appareil doit reposer pendant 5 heures avant d'être redémarré.

Instructions pour le matériel utilisant le réfrigérant R-454B.

AVERTISSEMENT

- **NE PAS percer ou brûler**
- **NE PAS utiliser d'autres moyens que ceux recommandés par le fabricant pour accélérer le processus de dégivrage ou pour nettoyer le matériel**
- **Sachez que les réfrigérants pourraient être inodores**

AVERTISSEMENT

- **l'appareil devrait être entreposé de manière à prévenir les dommages mécaniques et dans un local bien ventilé sans source d'allumage continue (ex., flammes vives, appareil au gaz en marche ou appareil de chauffage électrique en marche) et la taille de la pièce devrait être conforme aux spécifications (voir la section « Détermination de la superficie minimale du plancher »).**

Informations générales sur l'installation

AVERTISSEMENT

Zone ventilée : assurez-vous que la zone est à découvert ou qu'elle est correctement ventilée avant d'intervenir dans le système ou de réaliser tout travail à chaud. Un certain degré de ventilation devrait continuer pendant la période pendant laquelle le travail est effectué. La ventilation doit disperser en toute sécurité le réfrigérant libéré et l'expulser de préférence. Maintenez la zone de ventilation dégagée!

AVERTISSEMENT

N'UTILISEZ PAS de sources potentielles d'inflammation pour rechercher ou détecter des fuites de réfrigérant. Il ne faut pas utiliser de lampe haloïde (ou tout autre détecteur utilisant une flamme nue).

Les méthodes de détection de fuites suivantes sont jugées acceptables pour tous les systèmes frigorifiques. Des détecteurs électroniques de fuites peuvent être utilisés pour détecter les fuites de réfrigérant, mais dans le cas de RÉFRIGÉRANTS INFLAMMABLES, la sensibilité pourrait ne pas être adéquate ou nécessiter un nouvel étalonnage. (Le matériel de détection doit être étalonné dans une zone exempte de réfrigérant.) Assurez-vous que le détecteur n'est pas une source potentielle d'inflammation et qu'il convient au réfrigérant utilisé. Le matériel de détection de fuites doit être réglé à un pourcentage de la LII du réfrigérant et doit être étalonné en fonction du réfrigérant utilisé, et le pourcentage approprié de gaz (25 % maximum) doit être confirmé. Les liquides de détection de fuites peuvent également être utilisés avec la plupart des réfrigérants, mais l'utilisation de détergents contenant du chlore doit être évitée parce que le chlore peut réagir avec le réfrigérant et corroder la tuyauterie en cuivre. REMARQUE : les exemples de liquides de détection de fuites sont la méthode des bulles, les agents de la méthode fluorescente si une fuite est suspectée, les flammes nues doivent être enlevées/éteintes. En cas de fuite de réfrigérant nécessitant une soudure, tout le réfrigérant doit être récupéré du système ou isolé (au moyen de vannes d'isolement) dans une partie du système éloignée de la fuite. Le retrait du réfrigérant doit suivre la procédure décrite dans ce manuel.

Site d'installation

L'altitude maximale de cet équipement ne doit pas dépasser 3000 m. (9843 pi) et ne doit pas être installé à une altitude supérieure à 3000 m. À installer uniquement dans des endroits interdits d'accès au public.

AVERTISSEMENT

Pour les appareils utilisant des réfrigérants A2L reliés par un réseau de conduits d'air à une ou plusieurs salles, seuls les dispositifs auxiliaires approuvés par le fabricant de l'appareil ou déclarés appropriés au réfrigérant doivent être installés dans le réseau de gaines relié. Le fabricant doit lister dans les instructions tous les dispositifs auxiliaires approuvés par fabricant et le numéro de modèle à utiliser avec l'appareil spécifique si ces dispositifs sont susceptibles de devenir une source d'inflammation.

Espace d'installation requis

REMARQUE : Le matériel dont la charge de réfrigérant est inférieure à 64 oz n'exige pas une surface de plancher minimale et ne nécessite pas de capteur de détection de fuite de réfrigérant.

Le capteur peut être ajouté en tant que fonctionnalité.

AVERTISSEMENT

Le matériel contenant du réfrigérant R-454B doit être installé, utilisé et entreposé dans une salle dont la surface de plancher est plus grande que la surface définie dans le tableau « Surface de plancher minimale » en fonction de la charge totale de réfrigérant dans le système. Cette exigence s'applique aux matériels intérieurs avec ou sans capteur de fuite de réfrigérant d'usine.

ATTENTION

Ce matériel nécessite des raccordements à une source d'alimentation en eau. Voir la section « Recommandations pour la qualité de l'eau » de ce manuel pour plus d'informations sur la qualité de l'eau requise pour cette opération. Si une source d'eau potable est utilisée pour l'alimentation en eau de cet appareil, la source d'alimentation en eau doit être protégée contre le siphonnement à rebours par le matériel.

AVERTISSEMENT

Ce matériel est livré avec un dispositif de détection de réfrigérant installé en usine qui est capable de déterminer sa fin de vie utile spécifiée et les instructions de remplacement. Les capteurs de réfrigérant des systèmes de détection de réfrigérant ne doivent être remplacés que par des capteurs spécifiés par le fabricant de l'appareil.

AVERTISSEMENT

Prenez les précautions suffisantes en cas de fuite de réfrigérant. En cas de fuite de gaz réfrigérant, ventilez immédiatement la zone. RISQUES POSSIBLES : Des concentrations excessives de réfrigérant dans une salle fermée peuvent entraîner un manque d'oxygène.

AVERTISSEMENT

Récupérez TOUJOURS le réfrigérant. NE LE REJETEZ PAS directement dans l'environnement. Suivez minutieusement les instructions de manipulation conformément aux réglementations nationales.

Informations générales sur l'installation



AVERTISSEMENT

Assurez-vous que le câblage ne sera pas soumis à l'usure, à la corrosion, à une pression excessive, à des vibrations, à des bords tranchants ou à tout autre effet nocif de l'environnement. La vérification doit également tenir compte des effets du vieillissement ou des vibrations continues provenant de sources telles que les compresseurs ou les ventilateurs.

Détermination de la superficie minimale du plancher

Déterminez la charge totale de réfrigérant dans le système. Dans les systèmes emballés de thermopompes, la charge de l'usine doit correspondre à la charge totale du système et il ne devrait y avoir aucune raison d'ajouter de la charge sur le terrain. La plaque signalétique et le tableau des données physiques du matériel doivent servir de référence pour la charge totale. Les thermopompes dont la charge de réfrigérant est de 62 oz ou plus sont équipées d'un système d'atténuation de réfrigérant installé en usine.

L'équipement de la thermopompe est muni de conduits et utilise le ventilateur pour atténuer les fuites. Une fois que le capteur de fuite de réfrigérant détecte une fuite, le compresseur et le chauffage électrique sont désactivés, et le ventilateur fonctionne en mode de ventilation continue. Cela se produira pendant au moins cinq minutes et une alarme de commande se poursuivra jusqu'à ce que le capteur ne détecte plus de fuite.

La surface minimale d'installation de l'unité, S_{min} , est basée sur la charge de réfrigérant et la hauteur d'installation de l'unité, comme indiqué dans le tableau ci-dessous. Puisque cette thermopompe est munie de conduits et utilise le ventilateur pour atténuer les fuites, la surface de plancher zoné ou avec conduits doit être supérieure à TA_{min} indiquée dans le tableau ci-dessous. Si la thermopompe est zonée, les amortisseurs doivent s'ouvrir pour permettre au ventilateur de la thermopompe d'atténuer la fuite de réfrigérant. La vitesse du ventilateur en mode continu doit être réglée au-dessus de Q_{min} , comme indiqué dans le tableau ci-dessous. Le réglage du ventilateur en mode continu est un réglage d'usine pour dépasser le débit d'air minimal requis pour l'atténuation.

mètres	H _{alte}		FC
	mètres	pi	
0	0	0	1,00
200	656	215	1,00
400	1312	430	1,00
600	1968	645	1,00
800	2624	860	1,02
1000	3280	1075	1,05
1200	3937	1290	1,07
1400	4593	1505	1,10
1600	5249	1720	1,12
1800	5905	1935	1,15
2000	6561	2150	1,18
2200	7217	2365	1,21
2400	7874	2580	1,25
2600	8530	2795	1,28
2800	9186	3010	1,32
3000	9842	3225	1,36
3200	Non recommandé		

Lorsque l'emplacement de l'installation est situé au-dessus de 600 m (1969 pi), le facteur de réglage de l'altitude dans le tableau est nécessaire pour calculer la taille minimale de la salle.

Exemple : si vous installez une unité verticale O60. Si votre altitude est de 1600 m (5249 pi), votre facteur de superficie serait de 1,12. Si le poids de votre charge est de 2,154 kg (76 oz) à une installation à hauteur de plancher. La S_{min} aurait une superficie de 11,9 m² (127 pi²). Prenez 113,4 pi² x 1,12 pour une nouvelle S_{min} de 127 pi² (11,9 m²).

Informations générales sur l'installation

Superficie minimale du plancher

Modèle	Configuration	H _o			Charge		S _{min}		Q _{min}		TA _{min}	
		po	pi	m	lbm	oz	pi ²	m ²	pi ³ /min	m ³ /heure	pi ²	m ²
024-036	Verticale	54,4	4,53	1,38	4,0	64	95,5	8,9	108,2	183,9	60,0	5,6
	Inférieure	62,5	5,21	1,59	4,0	64	47,2	4,4	108,2	183,9	60,0	5,6
048	Verticale	54,4	4,53	1,38	5,9	95	141,8	13,2	160,6	273,0	89,0	8,3
	Inférieure	62,5	5,21	1,59	5,9	95	123,4	11,5	160,6	273,0	89,0	8,3
	Plancher horizontal	23,6	1,97	0,60	5,7	91	669,2	62,2	153,8	261,5	85,3	7,9
	Plancher horizontal + 2 pi	47,6	3,97	1,21	5,7	91	164,3	15,3	153,8	261,5	85,3	7,9
	Plancher horizontal + 4 pi	71,6	5,97	1,82	5,7	91	72,7	6,8	153,8	261,5	85,3	7,9
	Suspendu à l'horizontale	86,6	7,22	2,20	5,7	91	85,3	7,9	153,8	261,5	85,3	7,9
060	Verticale	58,4	4,87	1,48	6,9	110	159,7	14,8	185,9	316,1	103,1	9,6
	Inférieure	62,5	5,21	1,59	6,9	110	142,9	13,3	185,9	316,1	103,1	9,6
	Plancher horizontal	23,6	1,97	0,60	7,4	118	1125,2	104,5	199,4	339,0	110,6	10,3
	Plancher horizontal + 2 pi	47,6	3,97	1,21	7,4	118	276,3	25,7	199,4	339,0	110,6	10,3
	Plancher horizontal + 4 pi	71,6	5,97	1,82	7,4	118	122,2	11,3	199,4	339,0	110,6	10,3
	Suspendu à l'horizontale	86,6	7,22	2,20	7,4	118	110,6	10,3	199,4	339,0	110,6	10,3

6/19/24

Surface de plancher minimale OptiDry

Modèle	Configuration	H _o			Charge		S _{min}		Q _{min}		TA _{min}	
		po	pi	m	lbm	oz	pi ²	m ²	pi ³ /min	m ³ /heure	pi ²	m ²
036	Verticale	54,4	4,53	1,38	4,1	66	98,5	9,1	111,6	189,6	61,9	5,7
	Inférieure	62,5	5,21	1,59	4,1	66	50,2	4,7	111,6	189,6	61,9	5,7
048	Verticale	54,4	4,53	1,38	6,1	97	144,7	13,4	163,9	278,7	90,9	8,4
	Inférieure	62,5	5,21	1,59	6,1	97	126,0	11,7	163,9	278,7	90,9	8,4
	Plancher horizontal	23,6	1,97	0,60	5,8	93	698,9	64,9	157,2	267,2	87,2	8,1
	Plancher horizontal + 2 pi	47,6	3,97	1,21	5,8	93	171,6	15,9	157,2	267,2	87,2	8,1
	Plancher horizontal + 4 pi	71,6	5,97	1,82	5,8	93	75,9	7,0	157,2	267,2	87,2	8,1
	Suspendu à l'horizontale	86,6	7,22	2,20	5,8	93	87,2	8,1	157,2	267,2	87,2	8,1
060	Verticale	58,4	4,87	1,48	7,0	112	165,5	15,4	189,3	321,8	105,0	9,8
	Inférieure	62,5	5,21	1,59	7,0	112	145,5	13,5	189,3	321,8	105,0	9,8
	Plancher horizontal	23,6	1,97	0,60	7,5	120	1163,7	108,1	202,8	344,8	112,5	10,4
	Plancher horizontal + 2 pi	47,6	3,97	1,21	7,5	120	285,8	26,5	202,8	344,8	112,5	10,4
	Plancher horizontal + 4 pi	71,6	5,97	1,82	7,5	120	126,3	11,7	202,8	344,8	112,5	10,4
	Suspendu à l'horizontale	86,6	7,22	2,20	7,5	120	112,5	10,4	202,8	344,8	112,5	10,4

6/19/24

Informations générales sur l'installation

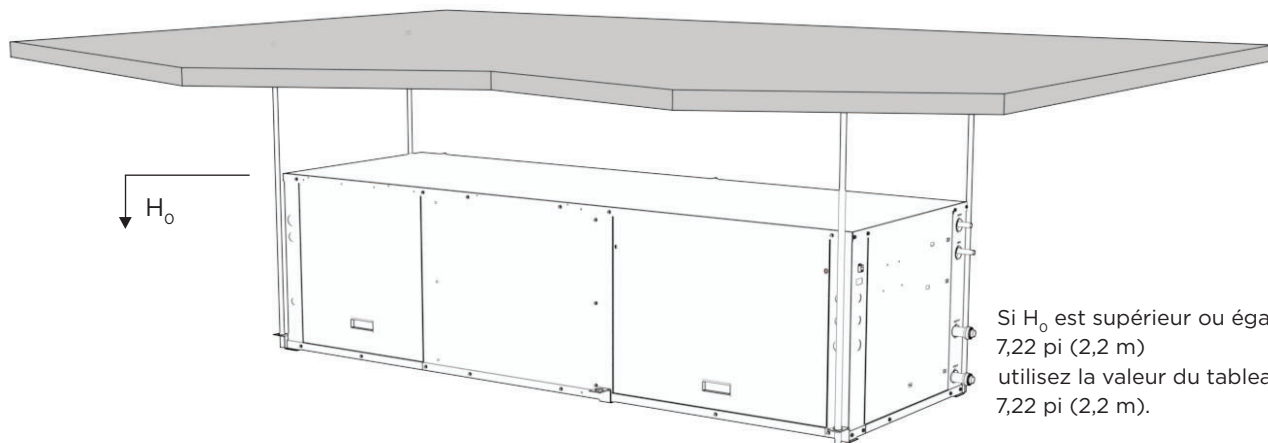

Si H_0 est supérieur ou égal à 7,22 pi (2,2 m) utilisez la valeur du tableau 7,22 pi (2,2 m).

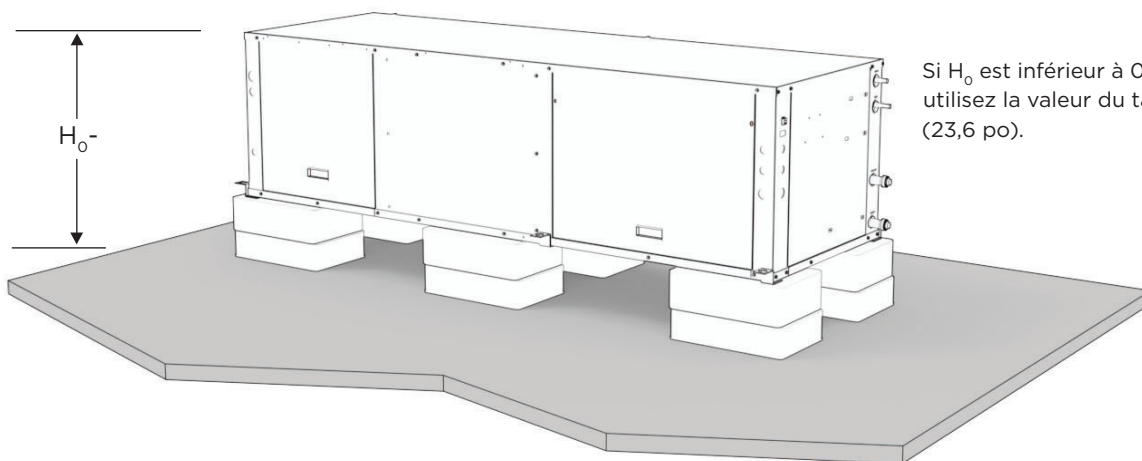

Si H_0 est inférieur à 0,6 m (23,6 po), utilisez la valeur du tableau 0,6 m (23,6 po).

Si H_0 se situe entre ces valeurs, utilisez le tableau pour calculer S_{\min} .

Informations générales sur l'installation

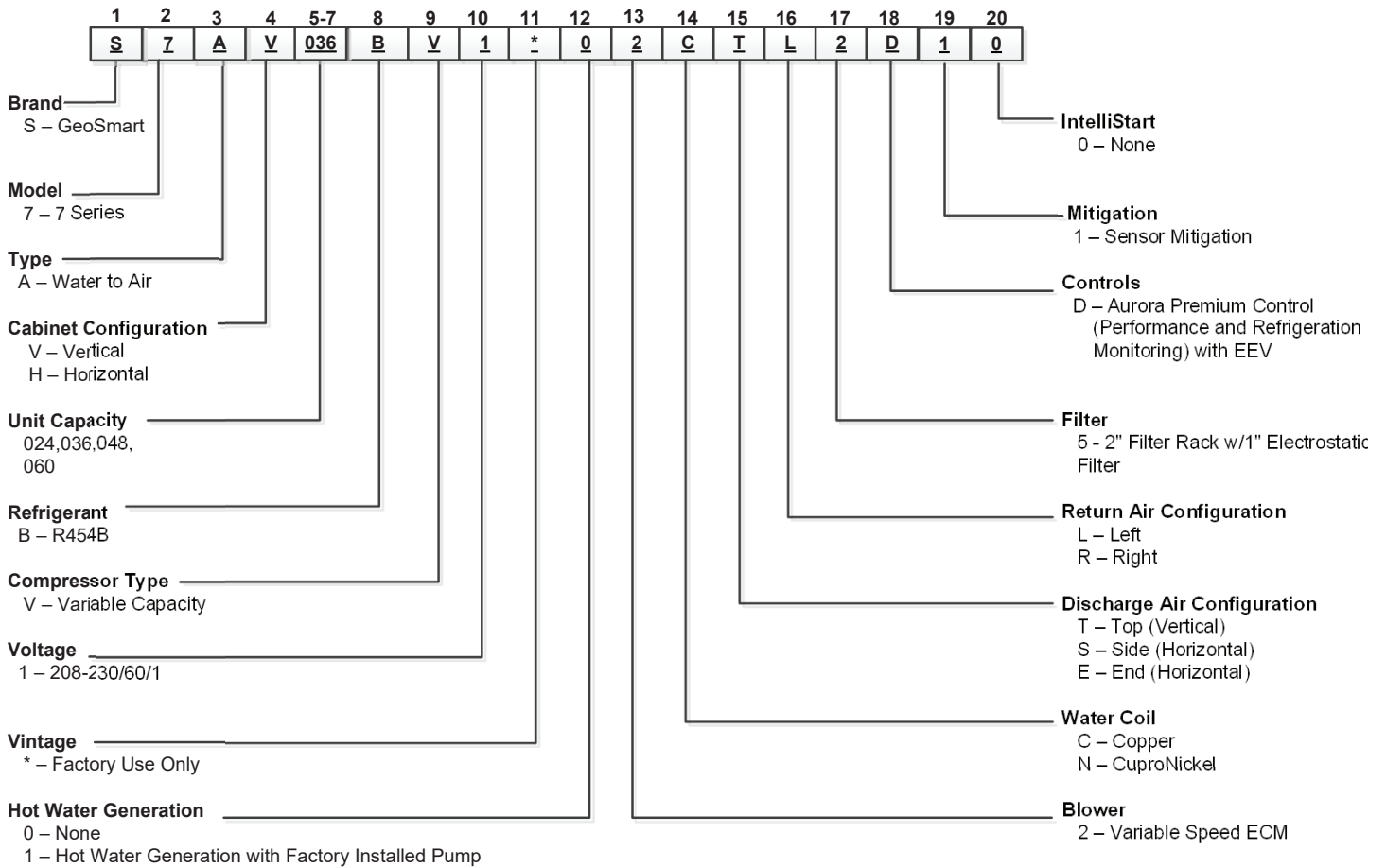

Rev.: 5/16/24

Renseignements généraux sur l'installation – Exemple de plaque de série

Unit Nomenclature and Serial Number	MODEL: JOB #:	S/N: 999999999 Manufactured Fort Wayne, Indiana USA							
Unit Voltage	Electrical Service								
	VAC/PHASE	Hz	FLA	MIN CIRCUIT AMPS	MIN/MAX VAC				
Fuse/Breaker Size	Short-Circuit Current			Fuse Circuit Breaker Size					
	kA Symmetrical	0	Max Fuse Time Delay	US Max HACR	Canada Max				
	V Maximum	0							
Component Electrical Information	Component	Qty	LRA	RLA/MRC	FLA	VAC	PH	HP	KW
Unit Restrictions	Other Data								
	Min. distance to combustible surface (in/cm)					/			
	Max. outlet air temperature (F/C)					/			
	Max. external static pressure (in water/Pa)					/			
	Max. inlet water temperature (F/C)					/			
	Max. inlet water pressure (in water/Pa)					/			
Auxiliary Heater Kit Electrical Installation	CK BOX	Heater Model	Supply Circuit	KW	Min CIR AMP	Max Fuse	Max BRKR		
	Mark heater installed with "X" in check box. For actual heater rating, see marking inside of unit.			Cocher "X" pour indiquer le modele installe pour les caracteristiques nominales des unites de chauffe voir le marquage a l'interieur.					
Unit Comments	Comments								
	Warning: Floor area for storage or operation must meet the minimum requirements shown. Minimum room area (operating or storage) 0 ft ² 0 m ² Minimum installation height 0 ft 0 m Note: For Minimum room areas at higher installation heights, see installation and operation manual. "For Installation Only in Locations Not Accessible to the General Public"								
Installation Requirements	MRC=Maximum Rated Current (only applicable for variable speed compressors/drives) Maximum allowable refrigerant pressure = PSIG/Mpa: /								
Refrigerant Type and Charge Amount	Refrigerant Type	Refrigerant Charge/Circuit			Design Pressure				
	R-454B	OZ				psi		Mpa	
		kg				High:			
						Low:			

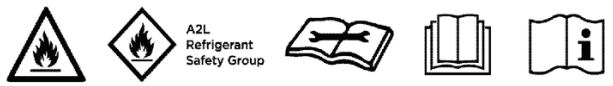

Informations générales sur l'installation

AVIS

AVIS : Pour éviter d'endommager l'équipement, ne laissez pas le système rempli dans un bâtiment sans chauffage par temps froid, à moins de prévoir des niveaux d'antigel adéquats pour la protection contre le gel. En effet, les échangeurs de chaleur ne se vident pas complètement et gèlent s'ils ne sont pas protégés, ce qui peut entraîner des dommages permanents.

AVIS : N'installez pas les unités dans un environnement corrosif ou dans des endroits soumis à des températures extrêmes ou à l'humidité élevée. Les conditions corrosives et des températures extrêmes ou à l'humidité élevée peuvent réduire de manière significative le rendement, la fiabilité et la durée de vie de l'appareil.

Considérations de sécurité



AVERTISSEMENT : Avant d'effectuer toute opération d'entretien ou de maintenance d'un système, coupez l'alimentation principale de l'unité intérieure. S'il y a lieu, éteignez l'interrupteur d'alimentation de la chaufferette accessoire. Le choc électrique peut provoquer des blessures.

L'installation et l'entretien des appareils de chauffage et de climatisation peuvent être dangereux en raison de la pression du système et des composants électriques. Seul un personnel formé et qualifié est habilité à procéder à l'installation, à la réparation ou à l'entretien des appareils de chauffage et de climatisation. Le personnel non formé peut effectuer les opérations d'entretien de base du nettoyage des bobines et du nettoyage et du remplacement des filtres. Toutes les autres opérations doivent être effectuées par du personnel d'entretien qualifié. Lors d'une intervention sur un appareil de chauffage ou de climatisation, veillez à respecter les précautions indiquées dans la documentation, les étiquettes apposées sur l'appareil et les autres mesures de sécurité éventuellement applicables.

Respectez tous les codes de sécurité. Portez des lunettes de sécurité et des gants de travail. Utilisez un chiffon mouillé pour toute opération de brasage et ayez un extincteur à disposition.

Déplacement et stockage

Déplacez les unités dans l'orientation normale « vers le haut ». Les unités horizontales peuvent être déplacées et entreposées conformément aux renseignements figurant sur l'emballage. Ne pas empiler plus de trois unités en hauteur totale. Les unités verticales peuvent être entreposées l'une sur l'autre jusqu'à une hauteur maximale de deux unités. Ne tentez pas de déplacer les unités lorsqu'elles sont empilées. Lors de la réception du matériel, tous les articles doivent être soigneusement vérifiés par rapport au connaissance afin de s'assurer que toutes les caisses et tous les cartons ont été reçus. Examinez les unités pour déceler les dommages causés par l'expédition et les retirer de l'emballage au besoin. Les unités en question devraient également faire l'objet d'une inspection interne. Si des dommages sont constatés, le transporteur doit l'indiquer sur le bordereau de livraison.

Emplacement de l'unité

Placez l'appareil à l'intérieur, à une température ambiante minimale de 45 °F et à une température ambiante maximale de 100 °F, ce qui permet d'enlever facilement le filtre et les panneaux d'accès. Les installations de grenier ne sont pas approuvées et pourraient entraîner une perte de garantie. L'installation n'est pas recommandée dans les zones où la saleté et les débris sont excessifs, car cela peut être aspiré dans le mécanisme

d'entraînement VS, ce qui entraîne une surchauffe de celui-ci. L'emplacement doit avoir suffisamment d'espace pour que le personnel d'entretien puisse effectuer l'entretien ou les réparations. Prévoir suffisamment d'espace pour faire des raccordements d'eau, d'électricité et de conduits. Si l'appareil est situé dans un espace confiné, comme un placard, des dispositions doivent être prises pour que le retour d'air pénètre librement dans l'espace au moyen d'une porte à volets, etc. Les vis de panneau d'accès qui seraient difficiles à enlever après l'installation de l'appareil doivent être enlevées avant de l'installer. Sur les appareils horizontaux, laisser suffisamment d'espace sous l'appareil pour accueillir un siphon de condensat et ne pas placer l'appareil au-dessus de la tuyauterie d'alimentation. **Lorsque les unités se trouvent dans des espaces non climatisés, il faut prendre soin d'éviter d'endommager les conduites d'eau gelées et d'empêcher une chaleur excessive qui pourrait endommager les composants électriques.**

Application du produit OptiDry

La fonction OptiDry offre une performance de déshumidification supérieure à toute autre solution et remplacera complètement le besoin de déshumidificateurs pour toute la maison. **Ce produit ne doit pas être utilisé avec une application pour piscine intérieure.**

Conversion du porte-filtre

Un filtre MERV de 2 po est expédié avec la thermopompe. Pour convertir le porte-filtre en utilisant des filtres de 1 po, il suffit d'insérer les goupilles en plastique fournies dans les trous situés dans le porte-filtre. Il y a des trous au haut et au bas du support, sous les étiquettes d'instructions, pour la conversion en filtres de 1 po.

Installation d'unités verticales

Avant de mettre l'appareil en place, retirez et jetez le boulon de fixation du compresseur situé à l'avant du support de fixation du compresseur.

Les unités verticales sont offertes avec une configuration de retour d'air à gauche ou à droite. Les unités verticales de refoulement d'air supérieures et arrière doivent être montées de niveau sur un tampon absorbant les vibrations légèrement plus grand que la base pour assurer l'isolation entre l'unité et le plancher (la configuration de refoulement arrière n'est pas offerte avec OptiDry). Il n'est pas nécessaire d'ancrer l'appareil au plancher (voir ci-dessous).

Les unités à débit bas (non offertes avec l'option de réchauffage au gaz chaud à modulation) doivent être installées de niveau et bien scellées au plancher pour éviter les fuites d'air. Les appareils à débit bas exigent que l'ouverture d'alimentation en air soit coupée d'au moins 1/2 po de plus que la sortie d'air de l'appareil. Protéger les bords des revêtements de sol combustibles avec une pellicule de tôle ou un autre matériau non-combustible.



Figure 1 : Montage de l'unité verticale

Informations générales sur l'installation (suite)

Installation d'unités horizontales

Enlevez et jetez le boulon d'expédition de maintien du compresseur situé à l'avant du support de fixation du compresseur avant de mettre l'appareil en place. Les unités horizontales sont disponibles avec évacuation latérale ou d'extrémité. Les unités horizontales sont normalement suspendues au plafond par quatre ou six tiges filetées de 3/8 po de diamètre. Les tiges sont généralement fixées à l'unité par des trousseaux de supports de suspension fournis avec chaque unité.

Disposez les tiges filetées selon les dimensions indiquées à la figure 3. Assemblez les crochets de suspension sur l'unité tel que démontré. Serrez solidement les supports à l'unité à l'aide des écrous à souder situés au-dessous du panneau inférieur. Lors de la fixation des tiges de suspension au support, un écrou

double est requis puisque la vibration pourrait desserrer un écrou simple. Pour permettre l'accès au filtre, un support du côté filtre doit être installé à 180° par rapport à la position montrée à la figure 3. L'appareil doit être incliné d'environ 1/4 po vers le drain dans les deux sens pour faciliter l'élimination du condensat. Utilisez uniquement les boulons fournis dans la trousse pour fixer les supports de suspension. L'utilisation de boulons plus longs pourrait endommager les pièces internes.

Certaines réglementations résidentielles nécessitent l'installation d'unités horizontales sur un plancher de grenier. Dans ce cas, l'appareil doit être placé dans un bac de récupération secondaire pleine grandeur sur un coussin absorbant les vibrations. Le bac de récupération secondaire empêche le débordement de condensat ou les dommages causés par les fuites d'eau au plafond. Le bac de récupération secondaire est généralement placé sur une base en contreplaqué isolée des solives du plafond à l'aide de couches supplémentaires de matériau absorbant les vibrations.

REMARQUE SPÉCIALE : L'entraînement VS est limité à une température ambiante maximale de 125 °F. Pour cette raison, l'appareil n'est pas approuvé pour les installations de grenier. La température du compartiment du compresseur est également surveillée par l'Aurora. Cette température ambiante du compresseur est disponible dans l'outil AID pour la lecture. La commande coupe le compresseur lorsque la température de l'air ambiant est supérieure à 125 °F. L'installation de ce produit dans un grenier pourrait entraîner une perte de garantie.

ATTENTION : N'utilisez pas de tiges de diamètre inférieur à 3/8 po, car elles pourraient ne pas être assez résistantes pour soutenir l'appareil. Les tiges doivent être solidement ancrées au plafond.

Figure 2 : Montage horizontal de l'unité

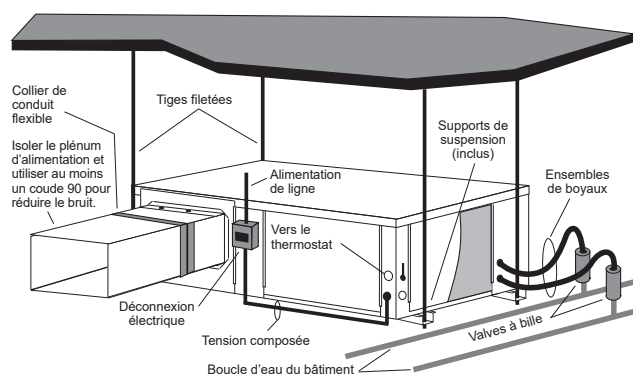
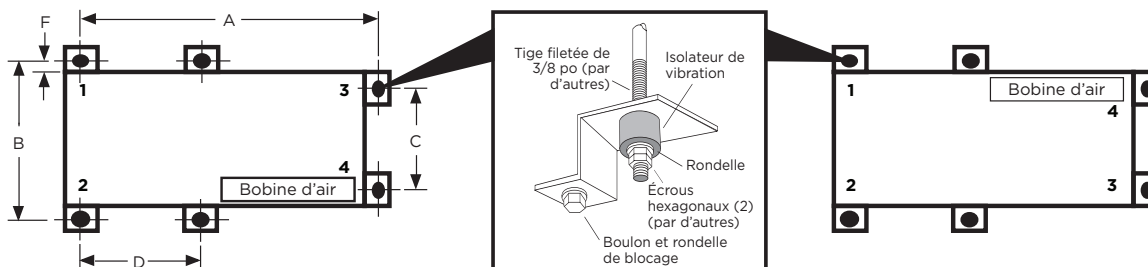

Figure 3 : Emplacement et assemblage des crochets



Répartition du poids

Modèle	Poids vertical	Poids horizontal	Répartition du poids horizontal			
			Avant		Arrière	
			1	2	3	4
024-036	331	365	120	80	83	82
048	354	388	143	84	81	80
060	372	402	143	98	81	80

5/10/24

Répartition du poids (option MHGR)

Modèle	Poids vertical	Poids horizontal	Répartition du poids horizontal			
			Avant		Arrière	
			1	2	3	4
036	382	387	127	85	88	87
048	418	452	167	98	94	93
060	444	494	176	120	100	98

5/10/24

Dimensions de la pièce de suspension

Modèle	Numéro de pièce de la trousse de suspension	Dimensions de la pièce de suspension de l'unité			
		A	B	C	D
024-036	po	77,4	27,8	24,1	29,3
	cm.	196,6	70,6	61,2	74,4
048	po	77,4	27,8	24,1	29,3
	cm.	196,6	70,6	61,2	74,4
060	po	82,4	27,8	24,1	29,3
	cm.	209,3	70,6	61,2	74,4

5/10/24

Informations générales sur l'installation (suite)

Système de conduits

Un collier de sortie d'air est fourni sur les appareils verticaux à sortie d'air par le haut et par l'arrière et sur toutes les unités horizontales pour faciliter le raccordement des conduits (les unités verticales à flux inférieur n'ont pas de collier). Un raccord flexible est recommandé pour les raccordements des conduits de refoulement et de reprise d'air sur les systèmes de conduits métalliques. Les conduits non isolés doivent être isolés au moyen d'un isolant de conduit d'au moins 1 po. L'utilisation de l'appareil sur des conduits non isolés dans un espace non climatisé n'est pas recommandée, car le rendement de l'appareil sera compromis.

Si l'appareil est raccordé à des conduits existants, vérifiez le système de conduits pour s'assurer qu'il a la capacité d'accueillir l'air requis pour l'utilisation de l'appareil. Si le conduit est trop petit, comme pour le remplacement des systèmes de chauffage seulement, des conduits plus grands devraient être installés. Tous les conduits existants devraient être vérifiés pour détecter les fuites et réparés au besoin.

Le système de conduits devrait être dimensionné conformément au tableau ci-dessous pour gérer le débit d'air de calcul de façon silencieuse et efficace. Pour maximiser l'atténuation sonore du ventilateur de l'appareil, les plénums d'alimentation et de retour devraient être munis d'une doublure de conduit interne en fibre de verre ou de panneaux d'isolation sur les premiers pieds. Dans les systèmes utilisant un système de conduits en tôle, des raccords en toile devraient être utilisés entre l'appareil et les conduits. Si un bruit d'air ou un débit d'air excessif est un problème, la vitesse du ventilateur peut être modifiée.

Modèle	Débit d'air de calcul
024	1200
036	1500
048	1800
060	2100

Tuyauterie d'eau

Le bon débit d'eau doit être fourni à chaque unité chaque fois que celle-ci fonctionne. Pour assurer un débit adéquat, utilisez des orifices de pression et de température pour déterminer le débit. Ces orifices devraient être situés aux raccordements d'alimentation et de retour d'eau de l'appareil. Le bon débit ne peut pas être réglé avec précision sans mesurer la chute de pression d'eau dans l'échangeur de chaleur de réfrigérant-eau.

Tous les raccords d'alimentation en eau des unités résidentielles sont des raccords de tuyauterie pivotants (voir la figure 4) qui acceptent un filetage mâle (MPT) de 1 po. Le raccord pivotant est doté d'un joint d'étanchéité en caoutchouc semblable à un joint d'étanchéité de tuyau en caoutchouc qui, lorsqu'il est raccordé à l'extrémité d'un tuyau fileté de 1 po, fournit un sceau d'étanchéité sans qu'il soit nécessaire d'utiliser un ruban d'étanchéité ou de la pâte d'étanchéité pour filetage. Assurez-vous que le joint en caoutchouc est dans le raccord pivotant avant de tenter une connexion. Les joints en caoutchouc sont expédiés fixés aux conduits d'eau. Pour effectuer la connexion à un système de boucle de sol, attachez le connecteur en laiton (fourni dans la

trousse de connecteur CK4LI) contre le joint en caoutchouc du connecteur pivotant et vissez l'anneau de verrouillage femelle sur le tuyau fileté, tout en maintenant le connecteur en laiton dans la direction souhaitée. Serrez les raccords à la main, puis serrez doucement le raccord avec une pince pour obtenir un joint étanche. Lors de la connexion à un système à boucle ouverte (eau souterraine), enfiler tout raccord MPT de 1 po (PVC SCH80 ou cuivre) dans le raccord pivotant et serrer de la même manière que ci-dessus. Le système de tuyauterie en boucle ouverte et fermée devrait comprendre des robinets de pression et de température pour assurer l'entretien.

N'utilisez jamais de tuyaux flexibles de moins de 1 po de diamètre intérieur sur l'appareil. Limitez la longueur du boyau à 10 pieds par raccord. Vérifiez soigneusement s'il y a des fuites d'eau.

Figure 4 : Raccords pivotants

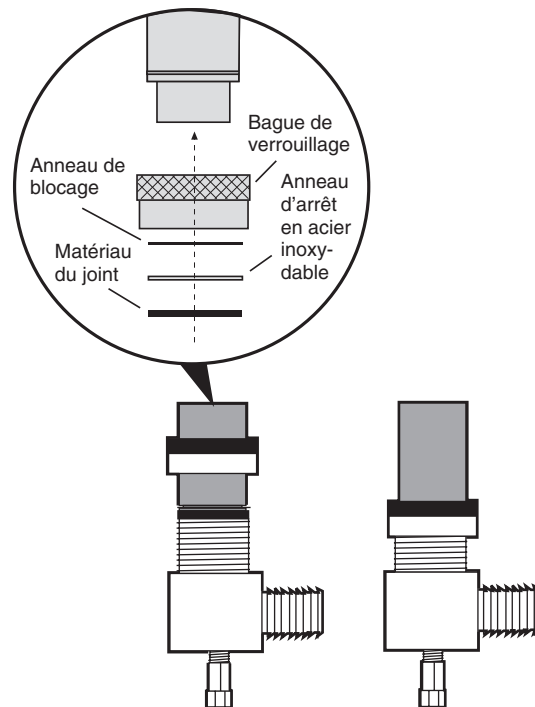

Informations générales sur l'installation (suite)

Drain de condensat

Sur les unités verticales, l'ensemble de drain de condensat interne se compose d'un tube d'évacuation relié au bac de récupération, d'un adaptateur femelle en PVC de 3/4 po et d'un tuyau flexible de raccordement. L'adaptateur femelle peut sortir de l'avant ou du côté de l'armoire. L'adaptateur devrait être collé à la tuyauterie de condensat en PVC installée sur place. Sur les unités verticales, un tuyau de condensat se trouve à l'intérieur de toutes les armoires comme une boucle de piégeage; par conséquent, un siphon externe n'est pas nécessaire.

Sur les unités horizontales, un embout en PVC est fourni pour le raccords de la tuyauterie de vidange du condensat. Un piège externe est requis (voir ci-dessous). Si un évent est nécessaire, un tuyau à support ouvert peut être appliqué sur un raccord en T dans la tuyauterie de condensat installée sur place.

Figure 5 : Raccord de drain horizontal

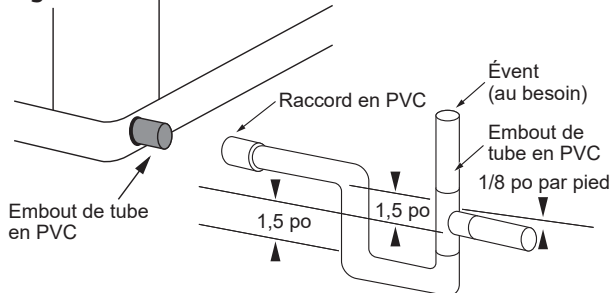

REMARQUE : Vérifiez les données dimensionnelles pour connaître les dimensions réelles du PVC.

Figure 6 : Hauteur de l'unité pour le drain

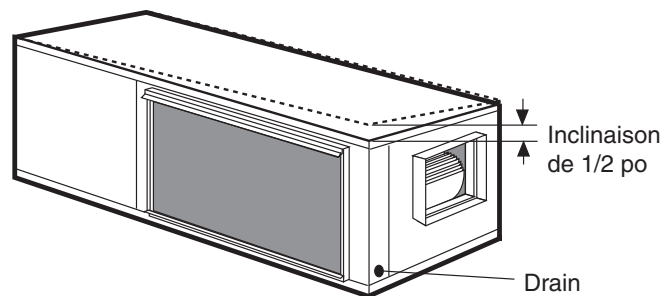

Qualité de l'eau

Matériel		Cuivre	90/10 Cupronickel	Acier inoxydable 316
pH	Acidité/Alcalinité	7 à 9	7 à 9	7 à 9
Entartrage	Calcium et carbonate de magnésium	(Dureté totale) moins de 350 ppm	(Dureté totale) moins de 350 ppm	(Dureté totale) moins de 350 ppm
Corrosion	Sulfure d'hydrogène	Moins de 0,5 ppm (une odeur d'œuf pourri se dégage à 0,5 ppm)	10 à 50 ppm	Moins de 1 ppm
	Sulfates	Moins de 125 ppm	Moins de 125 ppm	Moins de 200 ppm
	Chlore	Moins de 0,5 ppm	Moins de 0,5 ppm	Moins de 0,5 ppm
	Chlorures	Moins de 20 ppm	Moins de 125 ppm	Moins de 300 ppm
	Dioxyde de carbone	Moins de 50 ppm	10 à 50 ppm	10 à 50 ppm
	Ammoniac	Moins de 2 ppm	Moins de 2 ppm	Moins de 20 ppm
	Chlorure d'ammonium	Moins de 0,5 ppm	Moins de 0,5 ppm	Moins de 0,5 ppm
	Nitrate d'ammonium	Moins de 0,5 ppm	Moins de 0,5 ppm	Moins de 0,5 ppm
	Hydroxyde d'ammonium	Moins de 0,5 ppm	Moins de 0,5 ppm	Moins de 0,5 ppm
	Sulfate d'ammonium	Moins de 0,5 ppm	Moins de 0,5 ppm	Moins de 0,5 ppm
Encrassement par le fer (Croissance biologique)	Solides totaux dissous (TDS)	Moins de 1000 ppm	1000 - 1500 ppm	1000 - 1500 ppm
	Indice LSI	+0,5 à -0,5	+0,5 à -0,5	+0,5 à -0,5
Encrassement par le fer (Croissance biologique)	Fer, FE2+ (ferreux) Potentiel du fer bactérien	< 0,2 ppm	< 0,2 ppm	< 0,2 ppm
	Oxyde de fer	Moins de 1 ppm, au-delà de ce niveau, il y a dépôt	Moins de 1 ppm, au-delà de ce niveau, il y a dépôt	Moins de 1 ppm, au-delà de ce niveau, il y a dépôt
Érosion	Matières en suspension	Moins de 10 ppm et filtré pour une taille maximale de 600 microns	Moins de 10 ppm et filtré pour une taille maximale de 600 microns	Moins de 10 ppm et filtré pour une taille maximale de 600 microns
	Vitesse limite (Eau fraîche)	< 1,8 m/sec	< 1,8 m/sec	< 1,8 m/sec

NOTES : Grains = ppm divisé par 17 mg/L équivaut à ppm

Qualité de l'eau

Il incombe au concepteur du système et à l'entrepreneur chargé de l'installation de s'assurer que la qualité de l'eau est acceptable et que tous les codes applicables ont été respectés dans ces installations. Le non-respect des directives figurant dans le tableau de qualité de l'eau pourrait entraîner une perte de garantie. Dans les eaux souterraines où l'entartrage pourrait être important ou en cas de croissance biologique comme des bactéries ferreuses, un système en boucle fermée est recommandé. Les serpentins d'échangeur de chaleur des réseaux d'eau souterraine peuvent, sur une certaine période de temps, perdre leur capacité d'échange thermique en raison de l'accumulation de dépôts minéraux à l'intérieur. Ceux-ci peuvent être nettoyés, mais seulement par un mécanicien de service qualifié, car des solutions spéciales et de l'équipement de pompage sont requis. Les serpentins du générateur d'eau chaude peuvent également être entartrés et possiblement obstrués. Dans les endroits où l'eau est extrêmement dure, le propriétaire devrait être informé que l'échangeur de chaleur peut nécessiter un rinçage occasionnel.

Les thermopompes avec échangeurs de chaleur en cupronickel sont recommandées pour les applications en circuit ouvert en raison de la résistance accrue à l'accumulation et à la corrosion, ainsi que de la réduction de l'usure causée par le nettoyage à l'acide.

Traitement de l'eau

N'utilisez pas d'eau non traitée ou incorrectement traitée. L'équipement pourrait être endommagé. L'utilisation d'eau incorrectement traitée ou non traitée dans cet équipement peut entraîner la formation d'écaille, d'érosion, de corrosion, d'algues ou de substances visqueuses. L'achat d'un antigel pré mélangé pourrait améliorer considérablement la fiabilité du système si la qualité de l'eau est contrôlée et qu'il y a des additifs dans le mélange pour prévenir la corrosion. Il existe de nombreux exemples de tels liquides sur le marché aujourd'hui, comme

Enviroinol™ 1000 (éthanol pré mélangé), et d'autres. Les services d'un spécialiste qualifié en traitement de l'eau devraient être retenus pour déterminer le traitement requis, le cas échéant. La garantie du produit exclut expressément toute responsabilité en cas de corrosion, d'érosion ou de détérioration de l'équipement.

Les échangeurs de chaleur et les conduites d'eau des unités sont en cuivre ou en cupronickel. Il pourrait y avoir d'autres matériaux dans le système de tuyauterie du bâtiment que le concepteur devrait prendre en considération pour décider des paramètres de la qualité de l'eau. Si une solution antigel ou de traitement de l'eau est utilisée, le concepteur doit confirmer qu'elle n'a pas d'effet néfaste sur les matériaux du système.

Eau contaminée

Dans les applications où la qualité de l'eau ne peut être maintenue aux limites prescrites, l'utilisation d'un échangeur de chaleur secondaire ou intermédiaire est recommandée pour séparer l'unité de l'eau contaminée. Le tableau ci-dessus présente les recommandations relatives à la qualité de l'eau pour les échangeurs de chaleur des unités. Si ces conditions sont dépassées, un échangeur de chaleur secondaire est requis. Le défaut de fournir un échangeur de chaleur secondaire ou de ne pas en fournir entraînera une exclusion de la garantie en cas de corrosion ou de défaillance de l'échangeur de chaleur principal.

Limite du serpentins de bas niveau d'eau

Réglez le commutateur de détection de gel SW2-1, qui se trouve sur la carte de circuit imprimé du contrôleur de base Aurora (ABC) pour les applications utilisant une solution antigel en boucle fermée, sur « LOOP » (15 °F). Pour les applications utilisant un système d'eau souterraine à boucle ouverte (ou un système d'eau en boucle fermée sans antigel), réglez ce commutateur DIP sur « WELL » (30 °F), le réglage par défaut en usine. (Reportez-vous au tableau des paramètres du commutateur DIP dans la section du contrôleur Aurora.)

Raccords du générateur d'eau chaude

Pour optimiser les avantages du générateur d'eau chaude, un chauffe-eau d'au moins 50 gallons est recommandé. Pour les applications à forte demande, utilisez un chauffe-eau de 80 gallons ou deux chauffe-eau de 50 gallons connectés en série comme indiqué ci-dessous. Deux réservoirs raccordés en série sont recommandés pour maximiser la capacité du générateur d'eau chaude. Les chauffe-eau électriques sont recommandés. Assurez-vous que tous les codes d'électricité et de plomberie locaux sont respectés pour l'installation d'un générateur d'eau chaude. Les unités résidentielles dotées de générateurs d'eau chaude contiennent un circulateur interne et des raccords. Un adoucisseur d'eau est recommandé avec de l'eau dure (supérieure à 10 grains ou une dureté totale de 170).

NOTES : 1) L'utilisation d'un réservoir de préchauffage, comme il est indiqué à la figure 12, maximisera les capacités du générateur d'eau chaude. 2) Le serpentin du générateur d'eau chaude est faite de cuivre à double paroi ventilé convenant à l'eau potable.

Préparation du réservoir d'eau

Pour installer une unité munie d'un générateur d'eau chaude, suivez les directives d'installation suivantes.

1. Coupez l'alimentation du chauffe-eau.
2. Fixez un tuyau d'arrosage au raccord de vidange du réservoir d'eau et placez l'autre extrémité du tuyau dans un drain ouvert ou à l'extérieur.
3. Fermez la vanne d'entrée d'eau froide du réservoir du chauffe-eau.
4. Vidangez le réservoir en ouvrant la vanne au fond du réservoir, puis ouvrez la soupape de décharge ou le robinet d'eau chaude.
5. Rincez le réservoir en ouvrant la vanne d'entrée d'eau froide sur le chauffe-eau pour débarrasser le réservoir de sédiments. Fermez lorsque l'eau de vidange est claire.
6. Débranchez le tuyau d'arrosage et retirez le robinet de vidange du chauffe-eau.
7. Reportez-vous à la section Installation de plomberie et démarrage du générateur d'eau chaude.



ATTENTION : Les éléments brûlent s'ils sont sous tension et secs.

Figure 11 : Installation typique d'un générateur d'eau chaude

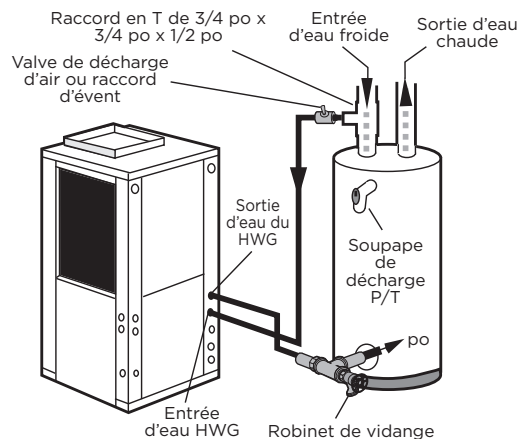
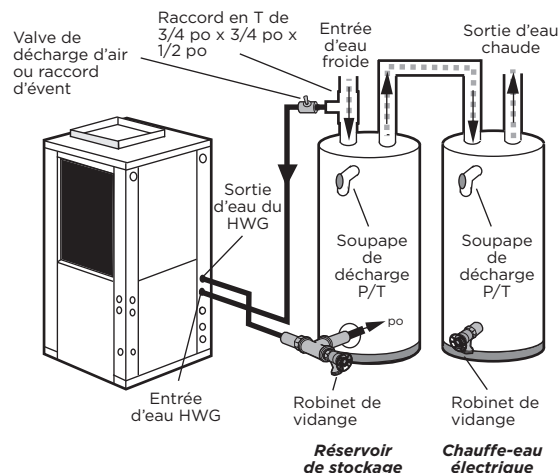

Figure 12 : Installation du générateur d'eau chaude dans le réservoir de préchauffage



REMARQUE : Cette configuration maximise la capacité du générateur d'eau chaude.

REMARQUE : Les tuyaux PEX ne sont pas recommandés pour la plomberie de production d'eau chaude. Si vous devez utiliser des tuyaux PEX, vous devez installer du cuivre sur l'appareil pour le premier 10 pi, puis passer au PEX.

Raccords du générateur d'eau chaude suite

Installation de plomberie

1. Inspectez le tube plongeur dans l'entrée froide du chauffe-eau pour déceler la présence d'un clapet antiretour. Si un clapet antiretour est présent, il doit être enlevé pour éviter d'endommager le circulateur du générateur d'eau chaude.
2. Enlevez le robinet de vidange et le raccord.
3. Enfilez le raccord mâle en laiton NPT de 3/4 po x 3 1/2 po dans l'orifice de vidange du chauffe-eau.
4. Fixez l'orifice central du raccord FPT en T de 3/4 po à l'extrémité opposée du raccord mâle en laiton.
5. Fixez le raccord en cuivre de 1/2 po à l'adaptateur NPT de 3/4 po sur le côté du raccord en T le plus près de l'appareil.
6. Installez le robinet de vidange sur le raccord en T, du côté opposé à l'adaptateur.
7. Passez le tube interconnecté du raccord en T à la sortie d'eau du générateur d'eau chaude.
8. Coupez la conduite d'eau froide d'ENTRÉE allant vers le chauffe-eau.
9. Insérez le raccord de réduction en T soudé dans la ligne d'entrée d'eau froide comme montré.
10. Faites fonctionner un tube en cuivre interconnecté entre l'entrée d'eau du générateur d'eau chaude de l'unité et le raccord en T (1/2 po nominal). La distance maximale recommandée est de 50 pieds.
11. Pour empêcher l'air de s'incruster dans le système, installez un raccord de ventilation au point le plus élevé des interconnexions des conduits.
12. Isolez toutes les surfaces exposées des deux conduites d'eau à l'aide d'un isolant mural à parois fermées de 3/8 po.

REMARQUE : Tous les raccords de plomberie et de tuyauterie doivent être conformes aux codes de plomberie locaux.

Interrupteur du générateur d'eau chaude

L'interrupteur du générateur d'eau chaude est fixé à la position désactivée par défaut.

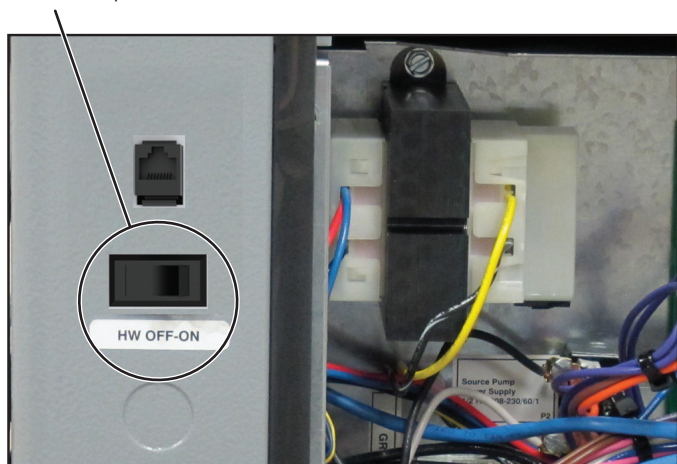

ATTENTION : N'utilisez jamais la pompe de circulation HWG lorsqu'elle est sèche. Si l'appareil est mis en marche avant que la tuyauterie du générateur d'eau chaude ne soit raccordée, s'assurer que l'interrupteur de la pompe est en position d'arrêt.

Démarrage de l'interrupteur du générateur d'eau chaude

1. Mettez l'interrupteur du générateur d'eau chaude à la position « ON ». Le commutateur de la génératrice à eau chaude permet au technicien d'entretien ou au propriétaire d'activer ou de désactiver la pompe de la génératrice à eau chaude.
2. Fermez le robinet de vidange du chauffe-eau.
3. Ouvrez l'alimentation en eau froide du réservoir.
4. Ouvrez un robinet d'eau chaude dans l'immeuble pour purger l'air du système. Fermer lorsqu'il est plein.
5. Ouvrez la soupape de décharge pour purger l'air restant du réservoir, puis fermer.
6. Si le véhicule en est équipé, tourner la vis de pression au centre de la pompe deux (2) tours pour l'ouvrir (l'eau s'écoulera), attendre que tout l'air soit purgé de la pompe, puis serrer le bouchon. Utilisez des raccords d'évent pour purger l'air des conduites.
7. Inspectez soigneusement toute la plomberie pour déceler toute fuite d'eau et corriger au besoin.
8. Avant de rétablir l'alimentation électrique du chauffe-eau, réglez le réglage de température du réservoir.
 - Sur les réservoirs dotés d'éléments supérieurs et inférieurs, l'élément inférieur doit être réduit au réglage le plus bas, soit environ 100 °F. L'élément supérieur doit être réglé à 120 °F à 130 °F. Selon les besoins particuliers du client, vous pouvez ajuster l'élément supérieur différemment.
 - Sur les réservoirs avec un seul élément, abaisser le réglage du thermostat à 120 °F.
9. Une fois le ou les thermostats réglés, replacer le couvercle d'accès et rétablir l'alimentation électrique du chauffe-eau.
10. Assurez-vous que toutes les vannes du circuit de circulation d'eau du générateur d'eau chaude sont ouvertes.
11. Utilisez un outil AIDE pour activer le HWG et sélectionnez le point de consigne de chauffage de l'eau souhaité. Les points de consigne sélectionnables sont de 100 °F à 140 °F par incréments de 5 °F (par défaut 130 °F). Dans le menu principal de l'outil AIDE, sélectionnez Setup, puis AXB Setup.
12. Mettez l'appareil en marche jusqu'au premier niveau de chauffage.
13. La pompe du générateur d'eau chaude devrait fonctionner. Au démarrage de la pompe, tourner la vis de mise à l'air libre (si équipé) au centre de la pompe deux (2) tours jusqu'à ce que l'eau s'écoule, puis la remplacer. Laissez la pompe fonctionner pendant au moins cinq minutes pour s'assurer que l'eau a bien rempli le circulateur. S'assurer que l'interrupteur de la pompe du générateur d'eau chaude est dans la position « ON ».
14. Laissez l'appareil chauffer de l'eau pendant 15 à 20 minutes pour s'assurer que le fonctionnement est normal.

Raccords électriques

Généralités

Assurez-vous que l'alimentation disponible correspond au même voltage et à la même phase que celles indiquées sur la plaque de série de l'appareil. Le câblage de ligne et de la basse tension doit être effectué conformément aux codes locaux ou au Code national de l'électricité, selon ce qui est applicable. Le compresseur ne présente aucune surcharge interne. Le disjoncteur dans le boîtier de commande est la protection contre les surcharges de l'entraînement et du compresseur. Le fait de contourner le disjoncteur pourrait endommager le compresseur et annuler la garantie.

Connexion d'alimentation de l'unité

Branchez les câbles de tension d'entrée à L1 et L2 du contacteur comme montré à la Figure 13c pour l'unité monophasée. Consultez les données électriques de l'unité du présent manuel pour connaître les tailles de fusibles appropriées.

Ouvrez le panneau d'accès inférieur avant. Retirez la fixation de sol du bas du boîtier de commande (Figure 13b). Ouvrez le boîtier de commande (Figure 13a). Insérez les câbles d'alimentation dans les alvéoles défonçables du côté inférieur gauche de l'armoire. Acheminez les fils par le côté gauche du boîtier de commande et connectez-les au contacteur et à la mise en terre (Figure 13c). Fermez la boîte de commande et remplacez la fixation de mise à la terre avant le démarrage de l'appareil.



ATTENTION : Des cycles fréquents d'alimentation du lecteur peuvent l'endommager! Attendre au moins 5 minutes entre les cycles (branchement et débranchement de l'alimentation de l'entraînement).

Figure 13a :

Accès aux fils (boîtier de commande ouvert)

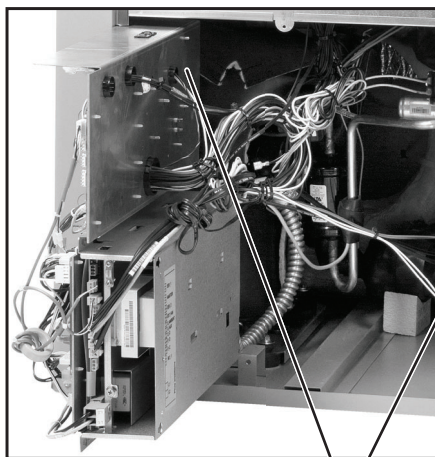

Emplacement de l'insert de fil

Figure 13b :

Accès aux fils (boîtier de commande fermé)

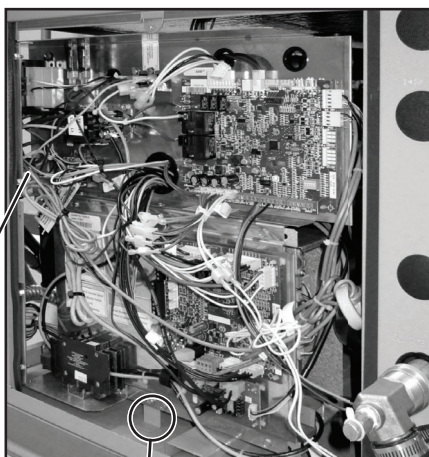

La fixation de mise en terre doit être installée pour assurer la mise en terre adéquate de l'unité.

Figure 13c :

Boîtier de commande pour tension de 208-230/60/1

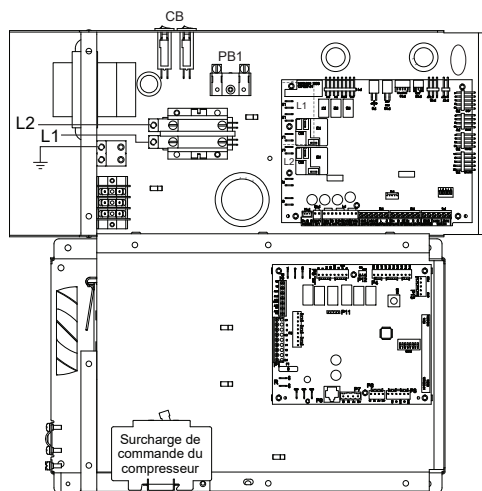

Relais d'accessoires

Un ensemble de contacts « secs » a été fourni pour commander les dispositifs accessoires, comme les électrovannes d'eau sur les installations à boucle ouverte, les épurateurs d'air électroniques, les humidificateurs, etc. Ce contact de relais ne doit être utilisé qu'avec des signaux de 24 volts et non avec une tension de ligne. Le relais a des contacts normalement ouverts et normalement fermés et peut fonctionner avec le ventilateur ou le compresseur. Utilisez les commutateurs DIP SW2-4 et 5 pour effectuer un cycle du du relais avec le ventilateur et le compresseur ou pour contrôler une vanne d'eau à ouverture lente. Les contacts de relais sont disponibles sur les bornes 1 et 3 pour une fermeture normale, et sur les bornes 2 et 3 pour une ouverture normale sur P2.

Un deuxième relais d'accessoires configurable est fourni sur la carte AXB. Lors de l'alimentation de composants à forte consommation de VA tels que les purificateurs d'air électroniques ou les vannes d'eau à circuit ouvert de type VM, R doit être pris en « pré-fusible » à partir du raccord rapide « R » sur la carte ABC et non à partir de la borne « R » en "post-fusible" sur la connexion du thermostat. Si ce n'est pas le cas, des fusibles ABC risquent de sauter.

Fonctionnement de 208 volts

Toutes les unités 208/230 sont câblées en usine pour un fonctionnement à 230 volts. Pour un fonctionnement de 208 volts, les fils de transformateur rouge et bleu doivent être branchés sur la barrette de connexion PS.

Raccords électriques suite

Câblage d'alimentation de la pompe

Voir la figure 14 pour les connexions électriques entre le boîtier de commande et les pompes.

Les centres de débit de style FC1/FC2 avec des pompes à vitesse fixe se connectent à PB1 dans le boîtier de commande. Si une pompe à vitesse variable est utilisée, elle doit être raccordée à L1 et L2 sur le AXB.

Les pompes à vitesse variable UPMXL 25-124 et Magna Geo sont conçues pour que la puissance soit appliquée aux commandes en tout temps. L'application de l'alimentation à la commande de la pompe au moyen d'un relais pour fonctionner comme en positions « OFF » et « ON » nuira à la fiabilité à long terme de la pompe VS.

Figure 14 : Câblage de la pompe 208-230/60/1

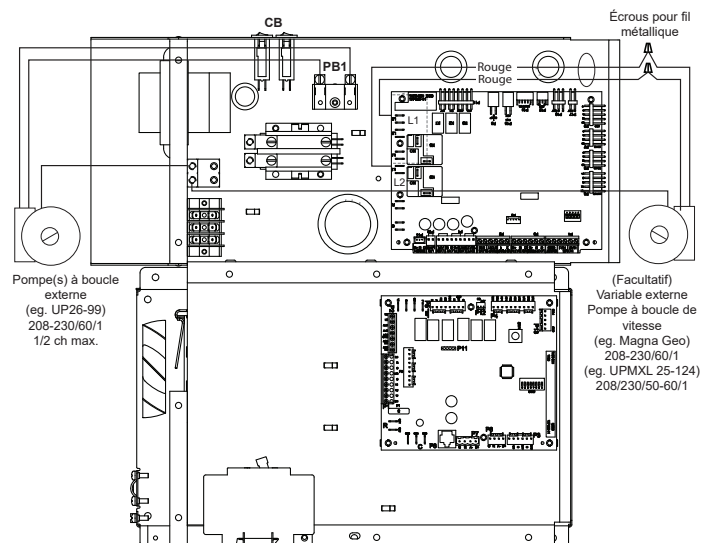

Installation du thermostat électronique

Placez la sous-base du thermostat contre le mur de façon à ce qu'elle soit de niveau et que les fils du thermostat dépassent au milieu de la sous-base. Marquez la position des trous de montage de la sous-base et percez les trous avec une mèche de 3/16 po. Installez les ancrages fournis et fixer la base au mur. Le fil du thermostat doit être à 4 conducteurs, 20 AWG (minimum). Dénudez les fils de 1/4 po (des bandes plus longues peuvent causer des courts-circuits) et insérez les fils du thermostat dans le connecteur comme montré. Serrez les vis pour assurer une connexion sécurisée. Le thermostat a les mêmes connecteurs, qui nécessitent le même câblage. Référez-vous aux instructions jointes au thermostat pour obtenir des renseignements détaillés sur l'installation et le fonctionnement. La borne W1 des thermostats communicants TPCM32U04A peut être câblée pour fournir de la chaleur auxiliaire/d'urgence en cas de perte de communication entre le thermostat et le microprocesseur ABC.

Figure 15 : Câblage du thermostat (signaux de communication)

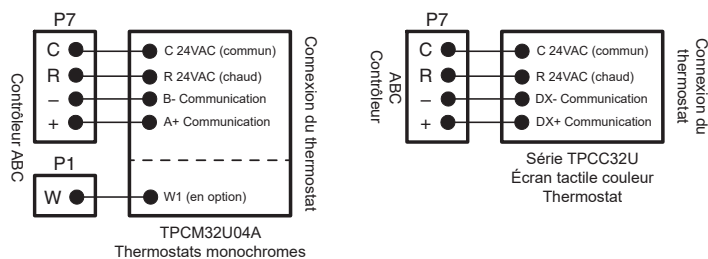

REMARQUE : Si vous utilisez le système de zonage IntelliZone2, ne tenez pas compte des diagrammes ci-dessus. Le système IntelliZone2 se connecte plutôt directement à la carte de contrôle AXB. Consultez le manuel d'installation d'IntelliZone2 pour plus de détails.

Données sur le rendement du ventilateur

Débit d'air à vitesse variable

Modèle	Pression statique (ESP) max	Vitesse 1	Vitesse 2	Vitesse 3	Vitesse 4	Vitesse 5	Vitesse 6	Vitesse 7	Vitesse 8	Vitesse 9	Vitesse 10	Vitesse 11	Vitesse 12
024***	0,50	285	380 G	525 L	675	815	980	1100 H	1220 Aux				
036	0,50	285	380 G	525 L	675	815	980	1100	1220	1330	1440 H	1540 Aux	1575
036 avec 1 ch*	0,75	480	565 G	665 L	761	870	1000	1100	1200	1300	1410 H	1520 Aux	1630
048	0,75	475	620 G	730 L	850	1020	1140	1270	1400	1520	1650 H	1790 Aux	1925
060	0,75	400	600 G	830 L	1050	1230	1400	1560	1700	1870	2010 H	2140 Aux	2265
**Par rapport à la vitesse du compresseur VS				1-2	3-4		5-6	7-8		9-10	11-12		

5/10/24

** La vitesse du compresseur VS est indiquée pour les réglages par défaut en usine en pi^3/min . Lorsque les paramètres par défaut sont modifiés, la relation avec la vitesse du compresseur qui est indiquée dans le tableau est modifiée. En mode de refroidissement, les vitesses 10 à 12 du compresseur ne sont disponibles que lorsque le mode SuperBoost est sélectionné au thermostat.

* ECM de 1 HP en option

Les réglages en usine sont aux positions G, L, H et Aux recommandées.

Le « G » peut se trouver n'importe où dans le tableau de débit d'air.

Le réglage « L » doit être situé dans la plage de PCM en gras.

Le réglage « H » DOIT être situé dans la plage de PCM ombrée.

Le réglage « aux » DOIT être égal ou supérieur au réglage « H ».

Le réglage « aux » DOIT être égal ou supérieur au PCM minimal admissible du nécessaire de chauffage auxiliaire (voir le tableau des caractéristiques de chauffage auxiliaire).

Le PCM est contrôlé à $\pm 5\%$ jusqu'à la pression statique ESP.

La pression statique (ESP) maximale comprend une tolérance pour serpentins humides et un filtre standard.

***Le fonctionnement du modèle 024 au-dessus de la vitesse 8 n'est PAS recommandé.

Réglage de la vitesse du ventilateur - ECM à vitesse variable

La DEL jaune du tableau de configuration ABC clignotera les sélections actuelles de vitesse ECM du ventilateur pour « G », basse et haute en continu avec une courte pause entre les deux. Les vitesses peuvent également être confirmées à l'aide de l'outil AIDE dans l'écran Paramètres/Paramètres ECM. La programmation Aux ne clignotera pas, mais peut être consultée dans l'outil AIDE. Les vitesses ECM du ventilateur du moteur peuvent être réglées sur place avec ou sans l'aide d'un outil AIDE.

Configuration du module de commande du moteur à vitesse variable sans outil AIDE

Les vitesses du ventilateur « G », faible (Y1), élevée (Y2) et auxiliaire peuvent être réglées directement sur le panneau Aurora ABC qui utilise le bouton (SW1) sur le panneau ABC. Cette procédure est décrite dans la section Mode de configuration du module de commande du moteur ECM de la section Système de commande de base d'Aurora. L'auxiliaire ne peut pas être réglé manuellement sans l'outil AIDE.

Configuration du module de commande de moteur à vitesse variable avec un outil AIDE

Une méthode beaucoup plus simple utilise l'outil AIDE pour modifier le débit d'air en suivant la procédure ci-dessous.

Accédez d'abord à l'écran Paramètre, puis sélectionnez Paramètres ECM. Cet écran affiche les réglages ECM actuels. Cela permet au technicien d'accéder aux écrans de configuration pour modifier les paramètres du moteur ECM. Modifiez l'élément mis en surbrillance à l'aide des boutons ◀ et ▶, puis appuyez sur le bouton ■ pour sélectionner l'élément.

Si vous sélectionnez OUI, la configuration de la vitesse du moteur ECM s'ouvrira, tandis que si vous sélectionnez NON, vous reviendrez à l'écran précédent.

Réglage de la vitesse du moteur ECM – Ces écrans permettent au technicien de sélectionner la vitesse « G », basse, élevée et auxiliaire du ventilateur d'air chaud du moteur ECM. Changer l'élément mis en surbrillance en utilisant les boutons ▲ et ▼. Appuyez sur le bouton ■ pour sélectionner la vitesse.

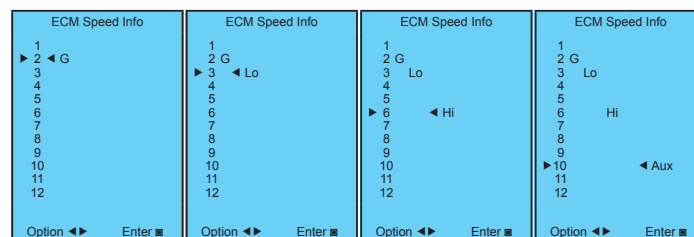

Une fois le réglage de la vitesse de chauffage auxiliaire sélectionné, l'outil AIDE retourne automatiquement à l'écran de configuration du moteur ECM.

Configuration du débit d'air de refroidissement – Ces écrans permettent au technicien de sélectionner -15 %, -10 %, -5 %, aucun ou une variation de +5 % par rapport au débit d'air de chauffage. Changer le pourcentage de réglage en utilisant les boutons ▲ et ▼. Appuyez sur le bouton ■ pour enregistrer la modification.

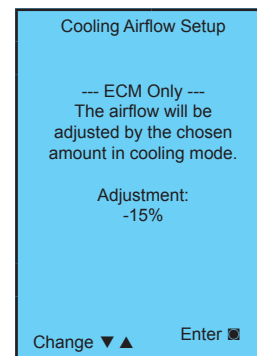
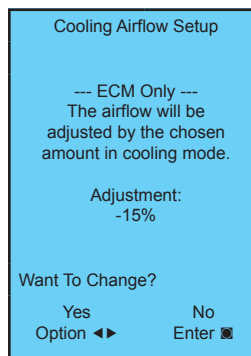
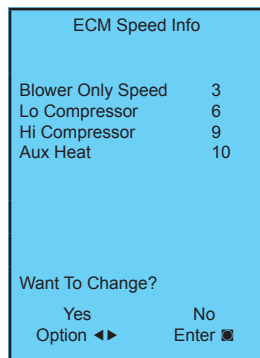

Données dimensionnelles verticales

Évacuation d'air supérieur

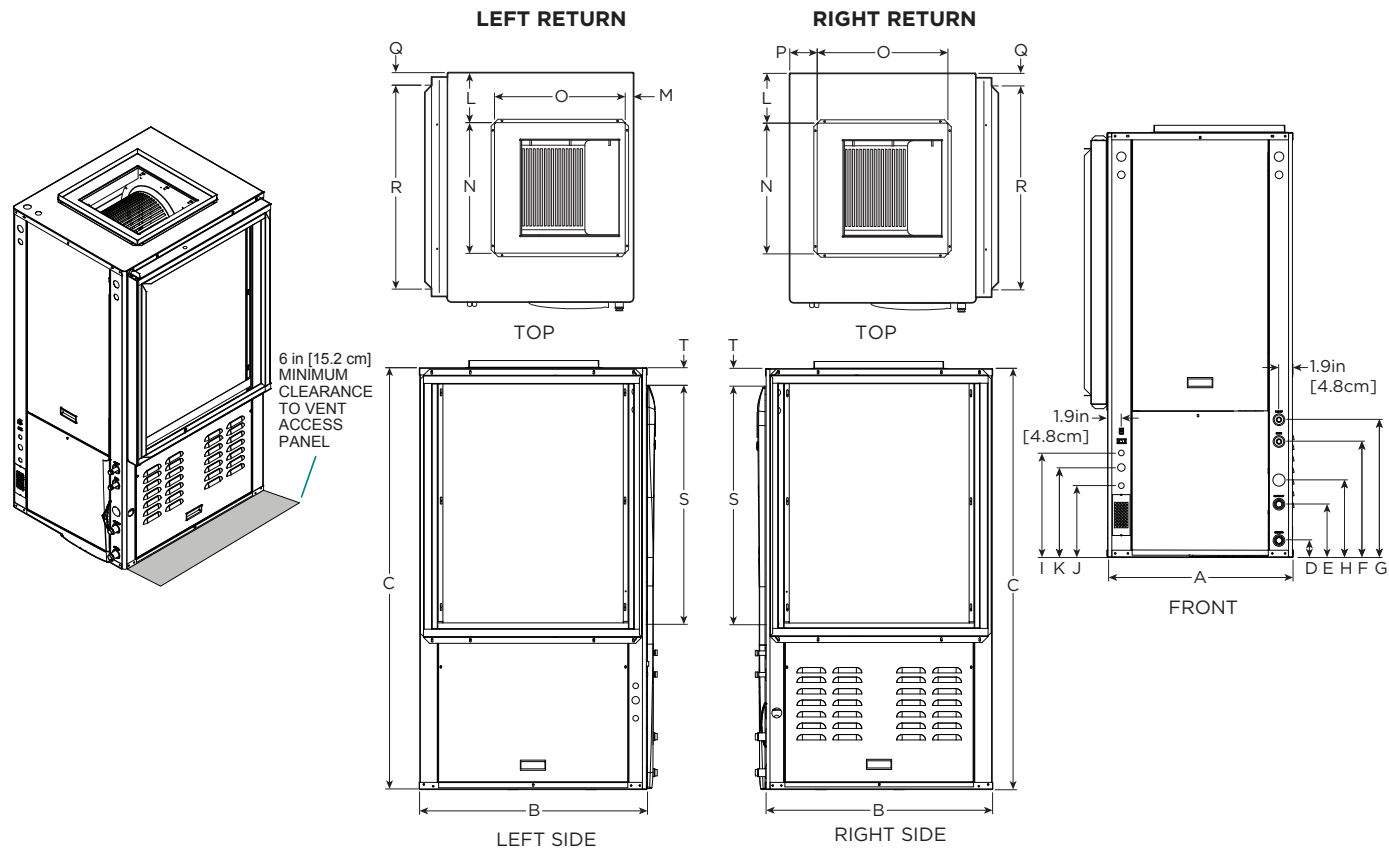

Modèle de flux supérieur vertical	Ensemble du Cabinet			Raccords d'eau							Raccords électriques			Raccord de décharge Bride de conduit installée (± 0,10 po)					Raccord de retour en utilisant un support de filtre standard de luxe (± 0,10 po)				
	A	B	C	D	E	F	G	H			I	J	K	L	M	N	O	P	Q	R	S	T	
	Lar- geur	Profon- deur	Hau- teur	Entrée en boucle	Sortie en boucle	Entrée HWG	Sortie HWG	Conden- sat	Boucle d'eau FPT	GTB (D.E.)	conden- sateur 1/2 po	1/2 po conden- sateur	Conden- sateur de 3/4 po			Largeur de l'ali- menta- tion	Profon- deur de l'ali- menta- tion			Profon- deur du re- tour	Hauteur du re- tour		
024-036	po	25,6	31,6	54,4	2,3	7,3	15,9	18,9	10,6	Pivo- tant de 1 po	Embout de 1/2 po	14,3	9,8	12,3	6,9	1,1	18,0	18,0	3,8	1,7	28,1	30,0	1,7
	cm.	65,0	80,3	138,2	5,8	18,5	40,4	48,0	26,9			36,3	24,9	31,2	17,5	2,8	45,7	45,7	9,7	4,3	71,4	76,2	4,3
048	po	25,6	31,6	54,4	2,3	7,3	15,9	18,9	10,6	Pivo- tant de 1 po	Embout de 1/2 po	14,3	9,8	12,3	6,9	1,1	18,0	18,0	3,8	1,7	28,1	30,0	1,7
	cm.	65,0	80,3	138,2	5,8	18,5	40,4	48,0	26,9			36,3	24,9	31,2	17,5	2,8	45,7	45,7	9,7	4,3	71,4	76,2	4,3
060	po	25,6	31,6	58,4	2,3	7,3	15,9	18,9	10,6	Pivo- tant de 1 po	Embout de 1/2 po	14,3	9,8	12,3	6,9	1,1	18,0	18,0	3,8	1,7	28,1	34,0	1,7
	cm.	65,0	80,3	148,3	5,8	18,5	40,4	48,0	26,9			36,3	24,9	31,2	17,5	2,8	45,7	45,7	9,7	4,3	71,4	86,4	4,3

Le condensat est un raccord femelle à coller en PVC de 3/4 po et est commutable du côté vers l'avant.

L'appareil est livré avec un collier de conduit/porte-filtre de luxe de 2 po (ajustable à 1 po) s'étendant de l'appareil de 3,25 po et convient pour le raccordement des conduits.

La bride de refoulement est installée sur place et se prolonge de 25,4 mm [1 po] de l'armoire.

Les moulures décoratives et/ou les raccords d'eau se prolongent de 30,5 mm (1,2 po) au-delà de l'avant de l'armoire.

Les événements à persiennes dans le panneau d'accès droit de la section du compresseur s'étendent à 12,7 mm [1/2 po] du côté de l'armoire. Prévoir un dégagement pour la ventilation.

05/10/24

Données dimensionnelles verticales (suite)

Évacuation d'air du fond

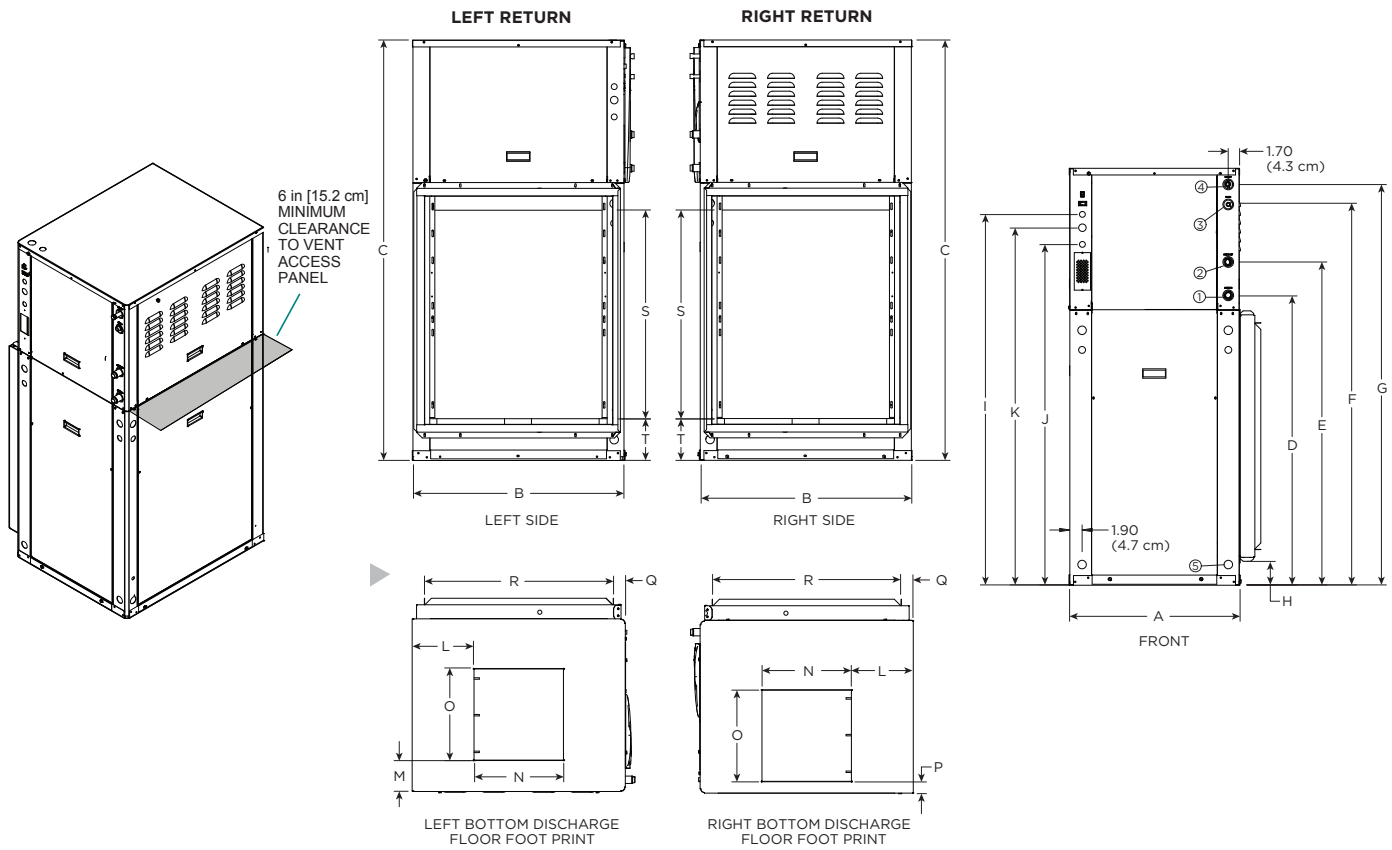

Modèles à débit bas	Ensemble du cabinet			Raccords d'eau							Entrées défonçables pour câbles électriques			Raccord de décharge bride de conduit installée (± 0,10 po)					Raccord de retour en utilisant un support de filtre standard de luxe (± 0,10 po)			
	A	B	C	1	2	3	4	5			I	J	K	L	M	N	O	P	Q	R	S	T
	Lar- geur	Pro- fon- deur	Hau- teur	D po	E Sor- tie	F Entrée HWG	G Sortie HWG	H Conden- sat	Boucle d'eau FPT	GTB (D.E.)	conden- sateur 1/2 po	conden- sateur 1/2 po	conden- sateur 3/4 po			Largeur de l'ali- menta- tion	Profon- deur de l'ali- menta- tion		Profon- deur du retour	Hau- teur du retour		
Q24-060	po cm.	25,5 64,8	31,5 80,0	62,5 158,8	43,4 110,2	48,4 122,9	57,0 144,8	60,0 152,4	3,1 7,9	Pivo- tant de 1 po Embout de 1/2 po	51,1 129,8	55,6 141,2	53,6 136,1	9,1 23,1	4,8 12,2	13,4 34,0	13,6 34,5	1,7 4,3	1,8 4,6	28,1 71,4	34,0 86,4	5,6 14,2

Le condensat est un raccord femelle à coller en PVC de 3/4 po et est commutable du côté vers l'avant.

L'appareil est livré avec un collier de conduit/porte-filtre de luxe de 2 po (ajustable à 1 po) s'étendant de l'appareil de 3,25 po et convient pour le raccordement des conduits.

Les moulures décoratives et/ou les raccords d'eau se prolongent de 30,5 mm (1,2 po) au-delà de l'avant de l'armoire.

Les événements à persiennes dans le panneau d'accès droit de la section du compresseur s'étendent à 12,7 mm [1/2 po] du côté de l'armoire. Prévoir un dégagement pour la ventilation.

5/10/24

Données dimensionnelles verticales (suite)

Refoulement d'air arrière

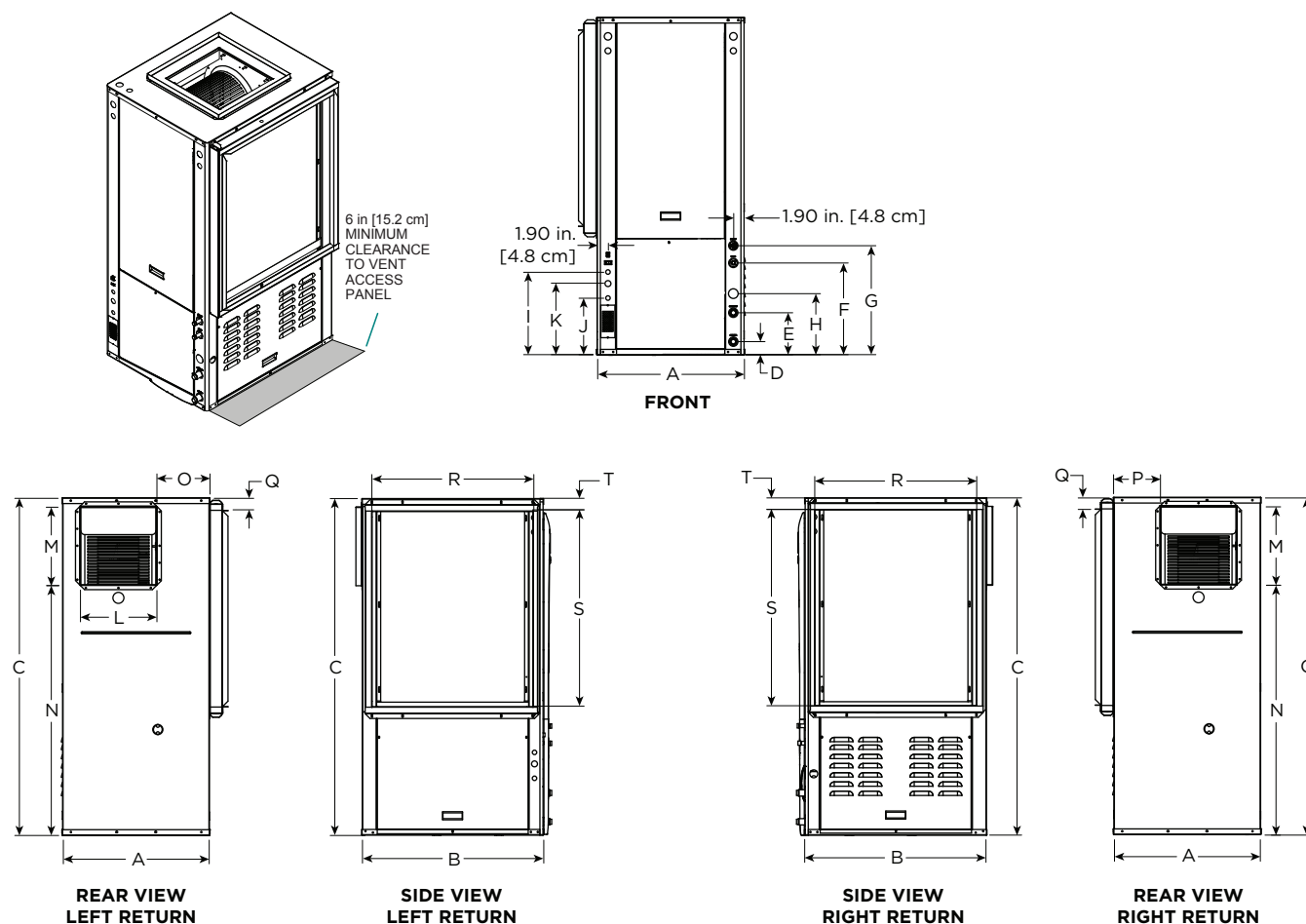

Modèle à décharge verticale arrière	Ensemble du cabinet			Raccords d'eau							Raccords électriques		Raccord de décharge bride de conduit installée (± 0,10 po)			Raccord de retour en utilisant un support de filtre standard de luxe (± 0,10 po)							
	A	B	C	D	E	F	G	H	Boucle d'eau FPT	Soudure de tuyaux de cuivre	I	J	K	L	M	N	O	P	Q	R	S	T	
	Lar-geur	Profon-deur	Hau-teur	Entrée en boucle	Sortie en boucle	Entrée HWG	Sortie HWG	Conden-sat			Conden-sateur 1/2 po	Conden-sateur 1/2 po	Conden-sateur 3/4 po	Largeur de l'alimen-tation	Profon-deur de l'alimen-tation				Profon-deur du retour	Hau-teur du retour			
036	po	25,6	31,6	54,4	2,3	7,3	15,9	18,9	10,6	Pivo-tant de 1 po	Embout de 1/2 po	14,3	9,8	12,3	13,3	13,6	39,4	9,1	8,1	1,7	28,1	30,0	1,7
	cm.	65,0	80,3	138,2	5,8	18,5	40,4	48,0	26,9			36,3	24,9	31,2	33,8	34,5	100,1	23,1	20,6	4,3	71,4	76,2	4,3
048	po	25,6	31,6	54,4	2,3	7,3	15,9	18,9	10,6	Pivo-tant de 1 po	Embout de 1/2 po	14,3	9,8	12,3	13,3	13,6	39,4	9,1	8,1	1,7	28,1	30,0	1,7
	cm.	65,0	80,3	138,2	5,8	18,5	40,4	48,0	26,9			36,3	24,9	31,2	33,8	34,5	100,1	23,1	20,6	4,3	71,4	76,2	4,3
060	po	25,6	31,6	58,4	2,3	7,3	15,9	18,9	10,6	Pivo-tant de 1 po	Embout de 1/2 po	14,3	9,8	12,3	13,3	13,6	43,4	9,1	8,1	1,7	28,1	34,0	1,7
	cm.	65,0	80,3	148,3	5,8	18,5	40,4	48,0	26,9			36,3	24,9	31,2	33,8	34,5	110,2	23,1	20,6	4,3	71,4	86,4	4,3

Le condensat est de 3/4 po. Raccord femelle à coller en PVC pouvant être commuté de côté à l'avant
L'appareil est livré avec un collier de conduit/porte-filtre de luxe de 2 po (ajustable à 1 po) se prolongeant de l'appareil de 3,25 po et convient au raccords des conduits.

6/29/12

La bride de décharge est installée sur place et se prolonge de 1 po [25,4 mm] de l'armoire.

Les moulures décoratives et/ou les raccords d'eau se prolongent de 30,5 mm [1,2 po] à l'avant de l'armoire.

Les événements à persiennes dans le panneau d'accès droit de la section du compresseur s'étendent à 12,7 mm [1/2 po] du côté de l'armoire. Prévoir un dégagement de 6 po pour la ventilation.

Données dimensionnelles horizontales

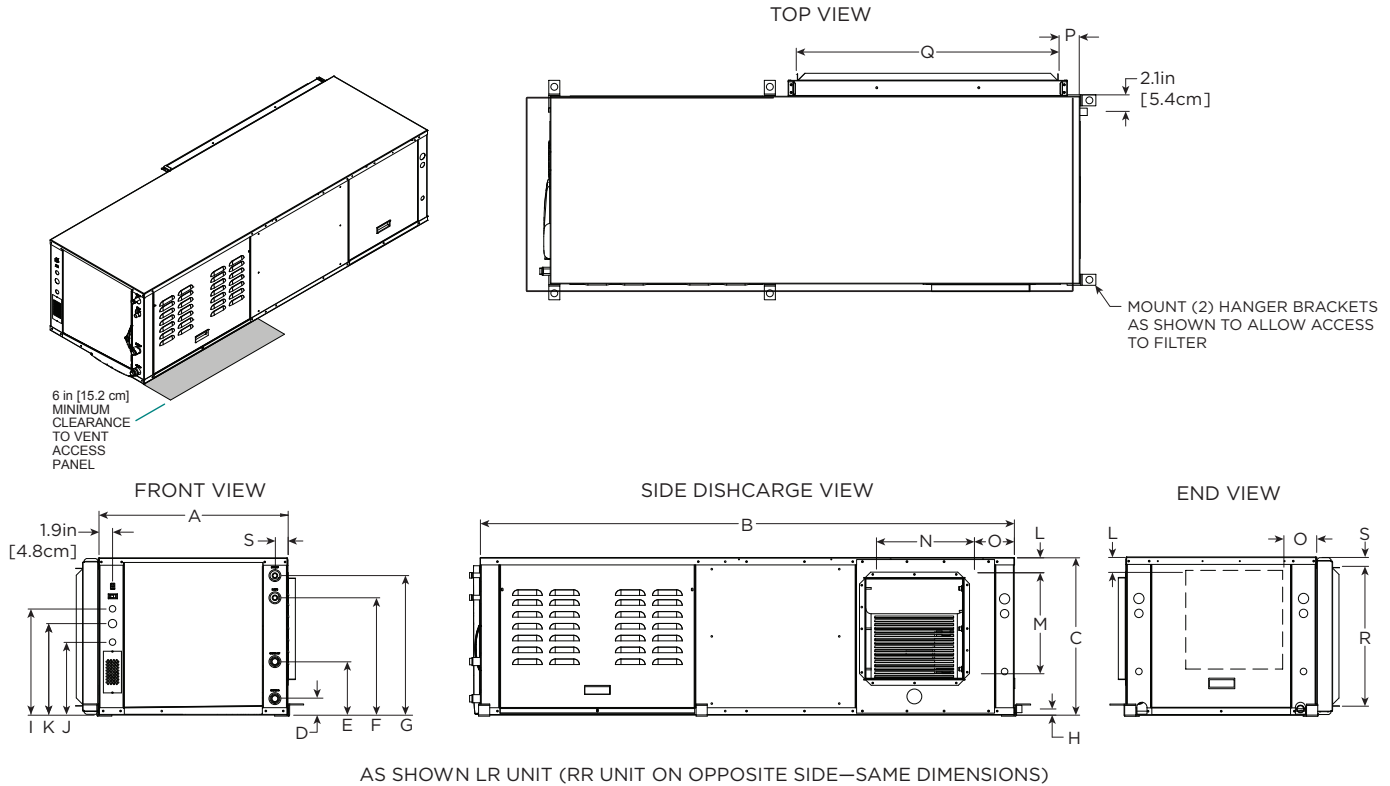

Modèles horizontaux	Ensemble du cabinet			Raccords d'eau								Raccords électriques			Raccord de décharge Bride de conduit installée (± 0,10 po)			Raccord de retour en utilisant un support de filtre standard de luxe (± 0,10 po)				
	A	B	C	D	E	F	G	H	Boucle d'eau FPT	GTB (D.E.)	I	J	K	L	M	N	O	P	Q	R	S	
	Lar-geur	Profon-deur	Hauteur	po	Sortie	Entrée HWG	Sortie HWG	Conden-sat			conden-sateur 1/2 po	conden-sateur 1/2 po	conden-sateur 3/4 po		Hauteur de l'alimen-tation	Profon-deur de l'alimen-tation			Profon-deur du retour	Hauteur du retour		
024-036	po	25,6	77,0	21,3	2,3	7,3	15,9	18,9	0,8	Pivotant de 1 po	Embout de 1/2 po	14,3	9,8	12,3	VOIR LE TABLEAU	13,6	13,2	VOIR LE TABLEAU	2,8	40,4	18,9	1,3
	cm.	65,0	195,6	54,1	5,8	18,5	40,4	48,0	2,0			36,3	24,9	31,2	34,5	33,5	7,1	102,6	48,0	3,3		
048	po	25,6	77,0	21,3	2,3	7,3	15,9	18,9	0,8	Pivotant de 1 po	Embout de 1/2 po	14,3	9,8	12,3	VOIR LE TABLEAU	13,6	13,2	VOIR LE TABLEAU	2,8	40,4	18,9	1,3
	cm.	65,0	195,6	54,1	5,8	18,5	40,4	48,0	2,0			36,3	24,9	31,2	34,5	33,5	7,1	102,6	48,0	3,3		
060	po	25,6	82,0	21,3	2,3	7,3	15,9	18,9	0,8	Pivotant de 1 po	Embout de 1/2 po	14,3	9,8	12,3	VOIR LE TABLEAU	13,6	13,2	VOIR LE TABLEAU	2,8	45,4	18,9	1,3
	cm.	65,0	208,3	54,1	5,8	18,5	40,4	48,0	2,0			36,3	24,9	31,2	34,5	33,5	7,1	115,3	48,0	3,3		

Le condensat est un raccord femelle à coller en PVC de 3/4 po et est commutable du côté vers l'avant.

5/10/24

L'appareil est livré avec un collier de conduit/porte-filtre de luxe de 2 po (ajustable à 1 po) s'étendant de l'appareil de 3,25 po et convient pour le raccordement des conduits. La bride de refoulement est installée sur place et se prolonge de 25,4 mm [1 po] de l'armoire.

Les moulures décoratives et/ou les raccords d'eau se prolongent de 30,5 mm (1,2 po) au-delà de l'avant de l'armoire.

Les événements à persiennes dans le panneau d'accès droit de la section du compresseur s'étendent à 12,7 mm [1/2 po] du côté de l'armoire. Prévoir un dégagement pour la ventilation.

Unités non illustrées ci-dessus		L	O
Décharge de l'extrémité du retour de droite	po	2,8	4,6
	cm	7,1	11,8
Décharge de côté du retour de droite	po	4,9	6,9
	cm	12,4	17,5
Décharge de l'extrémité du retour de gauche	po	4,9	7,6
	cm	12,4	19,4
Décharge de côté du retour de gauche	po	2,8	6,9
	cm	7,1	17,5

Données physiques

Modèle			024	036	048	060
Compresseur (1 chacun)			Spirale à vitesse variable			
Charge d'usine R-454B, oz [kg]	Verticale		64 [1,81]	64 [1,81]	95 [2,69]	110 [3,12]
Charge d'usine R-454B, oz [kg]	Horizontale		60 [1,70]	60 [1,70]	91 [2,58]	118 [3,35]
Charge d'usine R-454B, oz [kg] seulement	Verticale	MHGR	s/o	66 [1,87]	97 [2,75]	112 [3,18]
Charge d'usine R-454B, oz [kg] seulement	Horizontale	MHGR	s/o	62 [1,76]	93 [2,64]	120 [3,40]
Moteur du ventilateur de l'ECM et ventilateur						
Type/vitesses du moteur du ventilateur	ECM		Vitesse variable			
Moteur du ventilateur - ch [W]	ECM		1/2 [373]	1/2 [373]	1 [746]	1 [746]
Moteur de ventilateur à statique élevée - ch [W]	ECM		1 [746]	1 [746]	s/o	s/o
Dimensions de la roue du ventilateur (diamètre x W), po [mm]	ECM		11 x 10 [279 x 254]	11 x 10 [279 x 254]	11 x 10 [279 x 254]	11 x 10 [279 x 254]
Taille de roue du ventilateur statique élevée - [diamètre x I], po [mm]	ECM		11 x 10 [279 x 254]	11 x 10 [279 x 254]	s/o	s/o
Tuyauterie coaxiale et d'eau						
Dimensions des raccords d'eau - Pivotants - po [mm]			1 [25,4]	1 [25,4]	1 [25,4]	1 [25,4]
Taille de connexion HWG - embout - en [mm]			1/2 [12,7]	1/2 [12,7]	1/2 [12,7]	1/2 [12,7]
Volume d'eau de la tuyauterie coaxiale et de la tuyauterie - gal [l]			1,3 [4,9]	1,3 [4,9]	2,3 [8,7]	2,3 [8,7]
Verticale						
Dimension de la bobine d'air (H x W), po [mm]			32 x 25 [813 x 635]	32 x 25 [813 x 635]	32 x 25 [813 x 635]	36 x 25 [914 x 635]
Surface totale de la face de la bobine d'air, pi ² [m ²]			5,6 [0,570]	5,6 [0,570]	5,6 [0,570]	6,3 [0,641]
Taille du tube de la bobine d'air, po [mm]			3/8 [9,5]	3/8 [9,5]	3/8 [9,5]	3/8 [9,5]
Nombre de rangées de la bobine d'air			3	3	3	4
Dimensions du serpentin de réchauffage (H x L), po [mm] (MHGR seulement)			23 x 30 [584 x 762]	23 x 30 [584 x 762]	23 x 30 [584 x 762]	23 x 34 [584 x 864]
Filtre standard - 2 po [51 mm] Plissé MERV11 jetable, po [mm]			32 x 30 [813 x 762]	32 x 30 [813 x 762]	32 x 30 [813 x 762]	36 x 30 [914 x 762]
Poids - fonctionnement, lb [kg]			331 [150]	331 [150]	354 [161]	372 [169]
Poids - emballé, lb [kg]			351 [159]	351 [159]	374 [170]	392 [178]
Poids de fonctionnement, lb [kg] (MHGR seulement)			s/o	382 [173]	418 [190]	444 [201]
Poids emballé, lb [kg] (MHGR seulement)			s/o	402 [182]	438 [199]	464 [210]
Horizontale						
Dimension de la bobine d'air (H x W), po [mm]			20 x 40 [508 x 1016]	20 x 40 [508 x 1016]	20 x 40 [508 x 1016]	20 x 45 [508 x 1143]
Surface totale de la face de la bobine d'air, pi ² [m ²]			5,6 [0,570]	5,6 [0,570]	5,6 [0,570]	6,3 [0,641]
Taille du tube de la bobine d'air, po [mm]			3/8 [9,5]	3/8 [9,5]	3/8 [9,5]	3/8 [9,5]
Nombre de rangées de la bobine d'air			3	3	3	4
Dimensions du serpentin de réchauffage (H x L), po [mm] (MHGR seulement)			18 x 33 [457 x 838]	18 x 33 [457 x 838]	18 x 33 [457 x 838]	18 x 38 [457 x 965]
Filtre standard - 2 po [51 mm] Plissé MERV11 jetable, po [mm]			1 à 20 x 20 [508 x 508] 1 à 20 x 22 [508 x 559]	1 à 20 x 20 [508 x 508] 1 à 20 x 22 [508 x 559]	1 à 20 x 20 [508 x 508] 1 à 20 x 22 [508 x 559]	1 à 20 x 25 [508 x 635] 1 à 20 x 22 [508 x 559]
Poids - fonctionnement, lb [kg]			365 [166]	365 [166]	388 [176]	402 [182]
Poids - emballé, lb [kg]			395 [179]	395 [179]	418 [190]	432 [196]
Poids de fonctionnement, lb [kg] (MHGR seulement)			s/o	387 [176]	452 [205]	494 [224]
Poids emballé, lb [kg] (MHGR seulement)			s/o	407 [185]	482 [219]	514 [233]

Calculs de référence

Calculs de chauffage :	Calculs de refroidissement :
$LWT = EWT - \frac{HE}{gmp \times 500}$	$LWT = EWT + \frac{HR}{gmp \times 500}$
$LAT = EAT + \frac{HC}{pi^3/min \times 1,08}$	$LAT (DB) = EAT (DB) - \frac{SC}{pi^3/min \times 1,08}$
$TH = HC + HW$	$LC = TC - SC$
	$S/T = \frac{SC}{TC}$

Abréviations et définitions

pi^3/min	= débit d'air, pieds cubes/minute
EWT	= entering water temperature (température de l'entrée d'eau), Fahrenheit
gpm	= water flow in gallons/minute (débit d'eau en gallons/minute)
WPD	= water pressure drop (chute de pression d'eau), psi et pieds d'eau
EAT	= entering air temperature (température de l'air entrant), Fahrenheit (sèche/mouillée)
HC	= air heating capacity (capacité de chauffage de l'air), MBtu/h
TC	= total cooling capacity (capacité totale de refroidissement), MBtu/h
SC	= sensible cooling capacity (capacité de refroidissement sensible), MBtu/h
kW	= puissance totale d'entrée de l'unité, kilowatts
HR	= total heat of rejection (chaleur totale du rejet), MBtu/h
HE	= total heat of extraction (chaleur totale d'extraction), MBtu/h
HWC	= hot water generator capacity (capacité du générateur d'eau chaude), MBtu/h
EER	= Energy Efficient Ratio (rapport écoénergétique) = sortie BTU/entrée Watts
COP	= coefficient of performance (coefficient de performance) = sortie BTU/BTU entrée
LWT	= leaving water temperature (température de la sortie d'eau), °F
LAT	= leaving air temperature (température de la sortie d'air), °F
TH	= total heating capacity (capacité totale de chauffage), MBtu/h
LC	= latent cooling capacity (capacité latente de refroidissement), MBtu/h
S/T	= rapport de refroidissement sensible sur refroidissement total
DH	= Déshumidification
SST	= Température d'aspiration saturée
HPC	= Commande de pression de refoulement
MHGR	= Modulation du réchauffage au gaz chaud
RH	= Réchauffer

Limites de fonctionnement

Limites de fonctionnement	Refroidissement		Chauffage	
	(°F)	(°C)	(°F)	(°C)
Limites d'air				
Min. Air ambiant	45	7,2	45	7,2
Air ambiant prévu	80	26,7	70	21,1
Max. Air ambiant	100	37,8	85	29,4
Min. Entrée d'air	50	10,0	40	4,4
Débit d'air entrant db/wb	80,6/66,2	27/19	68	20,0
Max. Entrée d'air db/wb	110/83	43/28,3	80	26,7
Limites d'eau				
Min. Entrée d'eau	30	1,1	20	6,7
Entrée d'eau normale	50-110	10-43,3	30-70	1,1
Max. Entrée d'eau	120	48,9	90	32,2

REMARQUE : Les limites minimales et maximales ne s'appliquent qu'aux conditions de démarrage et visent à ramener l'espace à la température d'occupation. Les unités ne sont pas conçues pour fonctionner dans les conditions minimales/maximales de façon régulière. Les limites d'exploitation dépendent de trois facteurs principaux : 1) la température de l'eau, 2) la température du retour d'air et 3) la température ambiante. Lorsque l'un ou l'autre des facteurs se situe au niveau minimal ou maximal, les deux autres facteurs doivent être au niveau normal pour assurer un fonctionnement adéquat et fiable de l'appareil.

Retrait et évacuation du réfrigérant

Lorsque vous ouvrez le circuit frigorifique pour effectuer des réparations, ou pour toute autre fin, vous devez suivre les procédures conventionnelles. Cependant, pour les réfrigérants inflammables, vous devez suivre les meilleures pratiques parce que l'inflammabilité doit être prise en considération. La procédure suivante doit être respectée :

- retirez le réfrigérant en toute sécurité conformément aux réglementations locales et nationales;
- évacuez;
- purgez le circuit avec un gaz inerte (facultatif pour A2L);
- évacuez (facultatif pour A2L);
- rincez ou purgez continuellement avec un gaz inerte lors de l'utilisation d'une flamme pour ouvrir le circuit; et
- ouvrez le circuit.

La charge de réfrigérant doit être récupérée dans les bouteilles de récupération appropriées si la ventilation n'est pas autorisée par les codes locaux et nationaux. Pour les appareils contenant des réfrigérants inflammables, le système doit être purgé avec de l'azote exempt d'oxygène afin de rendre l'appareil sûr pour les réfrigérants inflammables.

Ce processus devra peut-être être répété plusieurs fois. L'air comprimé et l'oxygène ne doivent pas être utilisés pour purger les systèmes frigorifiques. Pour les appareils contenant des réfrigérants inflammables, la purge des réfrigérants doit être réalisée en rompant le vide dans le système avec de l'azote exempt d'oxygène et en continuant à le remplir jusqu'à ce que la pression de service soit atteinte, puis en dépressurant jusqu'à la pression atmosphérique, et enfin en créant un vide (facultatif pour A2L). Ce processus doit être répété jusqu'à ce qu'il n'y ait plus de réfrigérant dans le système (facultatif pour A2L). Lorsque la charge finale d'azote exempt d'oxygène est utilisée, le système doit être dépressurisé jusqu'à la pression atmosphérique pour permettre le travail. L'orifice de sortie de la pompe à vide ne doit pas se trouver à proximité de sources potentielles d'inflammation et une ventilation doit être disponible.

Procédures de chargement

En plus des procédures de chargement conventionnelles, les exigences suivantes doivent être respectées :

- S'assurer que les différents réfrigérants ne sont pas contaminés lors de l'utilisation de l'équipement de chargement.
- Les flexibles ou conduites doivent être aussi courts que possible pour réduire au minimum la quantité de réfrigérant qu'ils contiennent.
- Les bouteilles doivent être maintenues dans une position appropriée conformément aux instructions.
- S'assurer que le SYSTÈME FRIGORIFIQUE est mis à la terre avant de charger le système de réfrigérant.
- Étiqueter le système lorsque le chargement est terminé (si ce n'est pas déjà fait).
- Il convient de veiller très attentivement à ne pas trop remplir le SYSTÈME FRIGORIFIQUE.

Avant de recharger le système, il doit être soumis à un essai de pression avec le gaz de purge approprié. Le système doit être soumis à un essai d'étanchéité à la fin du chargement avant la mise en service. Un essai d'étanchéité de suivi doit être effectué avant de quitter le site.

Récupération du réfrigérant

Lors du retrait du réfrigérant d'un système, que ce soit pour l'entretien ou la mise hors service, il est recommandé de retirer tous les réfrigérants en toute sécurité.

Lors du transfert du réfrigérant dans des bouteilles, assurez-vous que seules des bouteilles appropriées de récupération de réfrigérant sont utilisées. Assurez-vous que le bon nombre de bouteilles pour contenir la charge totale du circuit est disponible. Toutes les bouteilles qui seront utilisées doivent être réservées au réfrigérant récupéré et étiquetées pour ce réfrigérant (c.-à-d. des bouteilles spéciales pour la récupération du réfrigérant). Les bouteilles doivent être équipées d'une soupape de surpression et de valves d'arrêt en bon état de fonctionnement. Les bouteilles de récupération vides sont évacuées et, si possible, refroidies avant la récupération.

Le matériel de récupération doit être en bon état de fonctionnement et inclure des instructions concernant le matériel disponible et doit convenir à la récupération du réfrigérant inflammable. En cas de doute, consultez le fabricant. De plus, un jeu de balances étalonnées doit être disponible et en bon état de fonctionnement. Les flexibles doivent être équipés de raccords rapides étanches et en bon état.

Le réfrigérant récupéré doit être traité conformément à la réglementation locale dans la bouteille de récupération appropriée, et le bordereau de transfert des déchets correspondant doit être rempli. Ne mélangez pas les réfrigérants dans les unités de récupération et surtout pas dans les bouteilles.

Si des compresseurs ou des huiles de compresseur doivent être retirés, assurez-vous qu'ils ont été purgés à un niveau acceptable pour s'assurer qu'il ne reste pas de réfrigérant inflammable dans le lubrifiant. Le corps du compresseur ne doit pas être chauffé par une flamme nue ou par d'autres sources d'inflammation pour accélérer ce processus. Lorsque l'huile d'un système est vidangée, la procédure doit être réalisée en toute sécurité.

Démarrage de l'unité

Avant d'alimenter l'appareil, vérifiez ce qui suit :

REMARQUE : Enlevez et jetez le boulon d'expédition de fixation de compresseur situé à l'avant du support de fixation du compresseur.

- **Les fils noir/blanc et gris/blanc du boîtier de commande de l'unité ont été enlevés si le chauffage auxiliaire a été installé.**
- **Les interrupteurs DIP sont réglés correctement.**
- **Transformateur changé à 208 V, s'il y a lieu.**
- **La haute tension est correcte et correspond à la plaque d'identification.**
- Les fusibles, les disjoncteurs et le calibre des fils sont appropriés.
- Le câblage basse tension est terminé
- La tuyauterie est terminée et le système d'eau est nettoyé et rincé.
- L'air est purgé du système en boucle fermée.
- Les valves d'isolation sont ouvertes et les valves de régulation d'eau ou les pompes du circuit sont câblées.
- La ligne de condensat est ouverte et inclinée correctement.
- L'interrupteur de la pompe du générateur d'eau chaude est « OFF » à moins que la tuyauterie ne soit terminée et que l'air ait été purgé.
- Le ventilateur tourne librement.
- La vitesse du ventilateur est correcte.
- Le filtre/purificateur d'air est propre et en place.
- Le filtre d'entraînement à vitesse variable est propre et en place.
- Les panneaux d'accès et d'entretien sont en place
- La température du retour d'air se situe entre 50 et 80 °F de chauffage et 60 et 95 °F de refroidissement.
- Vérifiez la propreté de la bobine d'air pour assurer un rendement optimal. Nettoyez au besoin selon les directives d'entretien. Pour obtenir un rendement maximal, la bobine d'air doit être nettoyée avant le démarrage. Une solution à 10 % de détergent pour lave-vaisselle et d'eau est recommandée pour les deux côtés de la bobine; un rinçage à l'eau complet devrait suivre.

Mise sous tension des commandes

Configuration initiale de l'unité

Avant d'utiliser l'appareil, mettez l'appareil sous tension et exécutez la procédure de démarrage Aurora suivante pour la configuration des commandes. Un outil AIDE est requis pour l'installation, la configuration et le dépannage du système à vitesse variable de la série 7. La version 2.04 ou plus récente de l'outil AIDE est préférable.

1. Configurer l'écran Aurora

- a. Confirmez que AXB a été ajouté et communiqué.
- b. Confirmez que le CPA est ajouté et communiqué.
- c. Confirmez que le contenant a été ajouté et communiqué.
- d. Confirmez que l'EEV2 est ajouté et communiqué.
- e. Confirmez qu'IntelliZone2 est ajouté et communiqué s'il est installé. Mettre le système de zonage sur OFF.
- f. Confirmez que le thermostat communicant est ajouté et communiqué si IntelliZone2 n'est pas installé. Réglez le mode du thermostat à OFF.

REMARQUE : Le COA et le GPM sont les deux tableaux qui composent le lecteur VS.

2. Écran de configuration Aurora

- a. Configuration du module de commande du moteur pour le chauffage du débit d'air – sélectionner les vitesses de soufflante G, basse, élevée et auxiliaire selon l'unité et la chaleur électrique.
- b. % du débit d'air de refroidissement – définit le % du débit d'air de refroidissement du débit d'air de chauffage. Le réglage d'usine est -15 %.
- c. Configuration AXB
 - i. DHW activé – Assurez-vous que l'air est purgé du système HW avant d'activer (n'oubliez pas le commutateur HW sur l'armoire avant).
 - ii. Point de consigne DHW – 130 °F est la valeur par défaut, mais peut être modifiée de 100 à 140 °F.
 - iii. Série 7 – Réglage de la pompe à vitesse variable et réglage de la vanne à eau modulante – Peut être réglé dans une plage de 5 % à 100 %. Les valeurs par défaut sont 50 % et 100 %.
 - Dans le menu principal de l'outil AIDE, allez à AXB Setup et sélectionnez « Yes » au bas de l'écran pour apporter des modifications.
 - Réglez la commande de pompe VS à MIN.
 - La ou les pompes ou le robinet d'eau devraient commencer à fonctionner et le débit est visible sur cet écran; il peut s'écouler plusieurs secondes avant que le débit se stabilise. Ajustez le % minimum jusqu'à ce que le débit minimal soit atteint.
 - Retournez à Régler la pompe VS et sélectionnez MAX.
 - La ou les pompes ou le robinet d'eau devraient commencer à fonctionner et le débit est visible sur cet écran; il peut s'écouler plusieurs secondes avant que le débit se stabilise. Ajustez le % maximum jusqu'à ce que le débit maximal soit atteint.
 - Appuyez sur Entrée.
- d. Configuration de la trousse de capteurs
 - i. Sélection de l'eau sursalée – pour le calcul de la capacité EH/RH.
 - ii. Débitmètre – active le débitmètre.
 - iii. Pompe – Sélectionnez la bonne option de centre de débit à l'aide du tableau ci-dessous. Si vous utilisez un système ouvert, sélectionnez « boucle ouverte ». Cette sélection est utilisée pour calculer les watts de pompage du système.

Écran de configuration de la trousse de capteur dans l'outil AIDE			
FC1	FC2	Pompe VS	Pompe VS X2
FC1-GL	FC2-GL	FCV1B-GL	VCF2B-GL
FC1-FPT	FC2-FPT		
FC1-GLNP	FC2-GLNP	FCV1B-GLNPP	FCV2B-GLNPP
FC2-GLNPD	FC4-GLNPD		
FC3-GLNPD (côté droit)	FC3-GLNPD (côté gauche)		
FCV2AB-GLNPD (côté droit)		FCV2AB-GLNPD (côté gauche)	
		FCV2BB-GLNPD (côtés droit et gauche)	
		FCV3CB-GLNPD (côté droit)	FCV3CB-GLNPD (côté gauche)
			FCV4AB-GLNPD (côtés droit et gauche)

Démarrage de l'unité

- iii. Activez l'option d'énergie
 - iv. Sélectionnez la puissance du ventilateur – PSC ou ECM/5 vitesses.
 - v. Étalonnage de la tension de ligne – Voltmètre requis pour étalonner la tension de ligne pendant le chauffage ou le refroidissement. Référez-vous à la section sur le calibrage de la tension du présent manuel pour plus de détails.
- e. Configuration du réseau intelligent – Sélectionner l'option d'action pour le signal reçu en période de pointe.
 - f. Configuration Domotique 1 et 2 – Sélectionnez le type de capteur pour deux entrées de domotique.
- e. La surveillance de la puissance peut être lue sur n'importe lequel des composants suivants :
 - i. Outil AIDE – information instantanée seulement
 - ii. TPCM32U04A Thermostat communicant (B/W) – information instantanée seulement
 - iii. Thermostat à écran tactile couleur TPCC32U01 – instantanément et historique (13 mois)
 - iv. Portail Web WaterFurnace via un dispositif AWL connecté à Aurora

Configuration des trousse de capteurs

Configuration des trousse de capteurs

Le système Aurora Advanced Control permet des trousse de capteurs de réfrigération, de puissance et de surveillance du rendement. Ces trousse peuvent être installées en usine ou sur place. La description suivante concerne l'activation sur le terrain d'une installation en usine des trousse de capteurs.

Surveillance de la puissance

(Ensemble de capteurs standard, modèles à vitesse variable)

Trousse de contrôle de la puissance la trousse de contrôle de l'énergie comprend deux transducteurs de courant (ventilateur et chaleur électrique) ajoutés aux deux capteurs de compresseur existants afin que la consommation d'énergie complète de la thermopompe puisse être mesurée. L'outil AIDE fournit des détails de configuration pour le type de moteur de soufflante et une procédure d'étalonnage de la tension de secteur pour améliorer la précision. Cette information peut être affichée sur l'outil AIDE ou sur les thermostats communicant sélectionnés. Le TPCM32U04A/TPCC32U affichera la consommation de puissance instantanée, tandis que l'écran tactile couleur TPCC32U02/MasterStat affichera également un historique de 13 mois sous forme de graphique. Assurez-vous que la trousse énergétique a été activée en accédant aux « Configuration de la trousse de capteurs » dans l'outil AIDE et effectuez ce qui suit :

- a. Sélectionnez « Puissance du ventilateur » – PSC ou ECM/5 vitesses.
- b. Activez « Option de puissance » pour activer les capteurs sur le compresseur (2), le ventilateur et le capteur de courant de chaleur auxiliaire.
- c. Sélectionnez l'option « Pompe » FC1, FC2, VS Pump, VS X2 Pump, VS + 26-99 ou boucle ouverte. Cela sélectionne les watts de la pompe utilisés dans le calcul. Les watts des pompes sont mesurés sur les pompes VS et estimés sur les pompes à vitesse fixe.
- d. Étalonnage de la tension de ligne – Voltmètre requis pour étalonner la tension de ligne pendant le chauffage ou le refroidissement.
 - i. Mettez l'appareil en marche dans le chauffage ou le refroidissement.
 - ii. Utilisez un multimètre aux niveaux L1 et L2 pour mesurer la tension secteur
 - iii. À l'écran Sensor Kit Setup, réglez la tension de base à la valeur la plus proche de celle mesurée.
 - iv. Utilisez ensuite le réglage fin pour sélectionner la tension exacte mesurée à L1 et L2.
 - v. Quittez l'écran « Configuration des capteurs ».

Surveillance du fluide frigorigène

(De série sur les modèles à vitesse variable)

La trousse de surveillance du fluide frigorigène en option comprend deux transducteurs de pression et trois capteurs de température, la conduite de liquide de chauffage, la température d'aspiration et la conduite de liquide de refroidissement existante (FPI). Ces capteurs permettent de mesurer les pressions de refoulement et d'aspiration, les températures des conduites d'aspiration et de liquide ainsi que la surchauffe et le sous-refroidissement. Ces renseignements ne seront affichés que dans l'outil AIDE. Assurez-vous que le système de surveillance du fluide frigorigène a été configuré en accédant à la section « Configuration de la trousse de capteurs » de l'outil AIDE et effectuez les tâches suivantes :

Une fois les capteurs installés pour la pression de refoulement, la pression d'aspiration, l'aspiration, le refroidissement de la conduite de liquide, le chauffage de la conduite de liquide et la température de la sortie d'air, aucune autre configuration n'est requise.

- a. Mettez l'appareil en marche dans le chauffage ou le refroidissement.
- b. Utilisez l'outil AIDE pour afficher le rendement du fluide frigorigène à l'écran « Réfrigérant Monitor ».
- c. La surveillance du fluide frigorigène peut être lue sur n'importe lequel des composants suivants :
 - i. Outil AIDE – information instantanée seulement
 - ii. Portail Web WF via un appareil AWL connecté à Aurora

Surveillance du rendement

(Ensemble de capteurs en option)

La trousse de surveillance du rendement en option comprend trois capteurs de température, soit l'entrée et la sortie de l'eau, la température de l'air sortant et un capteur de débit d'eau. Avec cette trousse, la chaleur d'extraction et de rejet sera calculée. Cela nécessite une configuration à l'aide de l'outil AIDE pour la sélection de l'eau ou de l'antigel. Assurez-vous que la trousse énergétique a été activée en accédant aux « Configuration de la trousse de capteurs » dans l'outil AIDE et effectuez ce qui suit :

- a. Sélectionnez « Eau sursalée », puis choisissez l'eau ou l'antigel pour le facteur approprié.
- b. Activez le débitmètre pour activer le débitmètre, sélectionnez le 3/4 po, 1 po ou aucun (1 po de série sur les unités à vitesse variable).
- c. Quittez l'écran « Sensor Kit Setup ».
 - i. Accédez à l'écran de configuration AXB et activer la commande de pompe VS.
 - ii. Réglez ensuite le % min. de la pompe VS pour atteindre au moins 2,5 gpm par tonne pour un fonctionnement à charge partielle.

Démarrage de l'unité

- iii. Réglez ensuite le pourcentage maximal de la pompe VS pour atteindre au moins 3,0 gal/min par tonne pour un fonctionnement à pleine charge.
- d. Mettez l'appareil en marche dans le chauffage ou le refroidissement.
- e. Utilisez l'outil AIDE pour afficher le rendement à l'écran « Moniteur de rendement ».
- f. La surveillance du rendement peut être lue pour l'un ou l'autre des éléments suivants :
 - i. Outil AIDE - information instantanée seulement
 - ii. Portail Web WaterFurnace via un dispositif AWL connecté à Aurora

- 14. Si des chaufferettes électriques auxiliaires sont installées, augmenter le point de consigne de chauffage jusqu'à ce que les banques de chaleur électriques soient mises en séquence (il faut atteindre la vitesse 12 du compresseur avant que le chauffage auxiliaire ne le permette). Toutes les étapes de la chaufferette auxiliaire doivent être mises en séquence lorsque le thermostat est en mode de chauffage d'urgence. Vérifiez l'ampérage de chaque élément.
- 15. Réglez le point de consigne de chauffage sous la température ambiante et vérifiez que le compresseur et la valve d'eau ou les pompes de la boucle sont désactivées.
- 16. Pendant tous les essais, vérifiez s'il y a des vibrations, des bruits ou des fuites d'eau excessives. Corrigez ou réparez au besoin.
- 17. Réglez le système au mode de fonctionnement normal désiré et réglez la température pour maintenir le niveau de confort désiré.
- 18. Informez le propriétaire/opérateur du bon fonctionnement du thermostat et de l'entretien du système.

Étapes de démarrage

REMARQUE : Remplissez la feuille de contrôle de démarrage/mise en service de l'équipement pendant cette procédure. Consultez les instructions d'utilisation du thermostat et terminer la procédure de démarrage. Vérifiez que le boulon d'expédition du compresseur a été enlevé.

1. Déclenchez un signal de commande pour mettre le moteur du ventilateur sous tension. Vérifiez le fonctionnement du ventilateur à l'aide de l'outil AIDE.
2. Déclenchez un signal de commande pour placer l'appareil en mode de refroidissement. Le point de référence du refroidissement doit être réglé sous la température ambiante.
3. Le refroidissement du première phase s'active après un délai de temps.
4. Assurez-vous que le compresseur et la valve de régulation de l'eau ou les pompes de la boucle sont activés.
5. Vérifiez que le débit d'eau est correct en mesurant la chute de pression dans l'échangeur thermique à l'aide des bouchons P/T et en la comparant aux données de rendement de l'unité dans le catalogue ou sur l'outil AIDE si la trousse de performance est installé.
6. Vérifiez la température de l'eau d'alimentation et de refoulement (voir les tableaux des paramètres de fonctionnement de l'unité).
7. Vérifiez si la température de l'air chute de 15 °F à 25 °F dans le serpentin d'air (vitesse 9 du compresseur de refroidissement), selon la vitesse de la soufflante et la température de l'eau entrée.
8. Diminuez le point de référence de refroidissement de plusieurs degrés et vérifiez le fonctionnement à haute vitesse du ventilateur.
9. Réglez le point de référence de refroidissement au-dessus de la température ambiante et vérifiez que le compresseur et la valve d'eau ou les pompes de la boucle est désactivée.
10. Déclenchez un signal de commande pour placer l'appareil en mode de chauffage. Le point de référence de chauffage doit être réglé au-dessus de la température ambiante.
11. Le chauffage de première phase s'active après un délai.
12. Vérifiez la température de l'eau d'alimentation et de refoulement (voir les tableaux des paramètres de fonctionnement de l'unité).
13. Vérifiez si la température de l'air augmente de 12 °F à 35 °F dans la bobine d'air (vitesse 12 du compresseur de chauffage), selon la vitesse du ventilateur et la température de l'entrée d'eau.

REMARQUE : Assurez-vous de remplir et de transmettre tous les documents d'enregistrement de garantie.

Notes

Guide de révision

Pages :	Description :	Date :	Par :
Toutes	Création de document	25 janvier 2024	SW

GEOSMART ENERGY



1-975 Bleams Road, Kitchener, ON N2E 3Z5, Canada | o: 1.866.310.6690 | f: 1.866.533.3889

GEOSMARTENERGY.COM



Product: **Premium V Series**
Type: Variable Speed Geothermal/Water Source Heat Pumps
Size: 3 - 5 Ton Variable Speed

Document Type: Installation Guide
Ref. Number: IGW7-0018S
Revision Date: 08/24
Revision Number: 1
Document Name: